



ACME Electronics Corporation
越峰電子材料股份有限公司

客户
CUSTOMER

PLATAN

日期
DATE 2025/5/16

认 可 书
SPECIFICATION FOR APPROVAL

客户品名 CUSTOMER P/N	PM 87 BOBBIN	
越峰品名 ACME P/N	AMAOT25506BX-W	
版本号 REV. NO.	0	

为保证订单顺利完成，请在一个月内签回。否则，将默认贵司同意依此份认可书内容制作您所有此规格的订单产品。

In order to ensure the leadtime for your order, pls confirm and sign this spec for ACME within one month while you received it. Or else, it means that you have approved this spec, and you have agreed with that ferrite cores from your order be produced according to this spec.

客户认可 APPROVED BY :

如有客户品码（料号），请填写在下
客户品码（料号）：
CUSTOMER P/N

- 厂别 Factory
- 总公司：台北市内湖区基湖路39号8楼B室
Head Office: 8th Floor, No.39, Ji-Hu Rd., Nei-Hu Dist., Taipei 114, Taiwan, R.O.C.
Tel: +886-2-2798-0337 Fax: +886-2-2659-9511 E-Mail: sales@acme-ferrite.com.tw
 - 观音厂：台湾省桃园县328观音工业区国建二路2号
No.2, Kuo-Chien 2nd Rd, Kuan-Yin Industrial District, Taoyuan County 328, Taiwan, R.O.C.
Tel: +886-3-483-7238 Fax: +886-3-483-7239
 - 广州厂：越峰电子(广州)有限公司 / 中国广东省广州增城市增江街东区府前东路2号
No.2 Fuqian East Road, Zengjiang Street East Square, Guangzhou-Zengcheng City, Guangdong Province, China.
Tel: +86-20-3285-1888 Fax: +86-20-3285-1666
 - 昆山厂：越峰电子(昆山)有限公司 / 中国江苏省昆山市黄浦江北路533号
No.533, Huangpujiang North Rd., Kunshan City
Tel: +86-512-5793-2888 Fax: +86-512-5766-4667

批准	审核	拟制
APPROVED BY	CHECKED BY	PREPARED BY
Jeff	Jeff	Jackson



ACME Electronics Corporation
越峰電子材料股份有限公司

历史变更记录
REVISION RECORDS LIST

客户 CUSTOMER:	PLATAN	CUSTOMER P/N	PM 87 BOBBIN
		ACME P/N	AMAOT25506BX-W

更改记录 REVISION RECORD:

版本号 REV. NO.	更改内容及原因 CONTENTS AND REASONS	日期 DATE OF APPROVAL	担当 DRAWN
0	NEW SPEC	2025/5/15	Evan.wang



1 外形尺寸 Outer Dimension(mm)

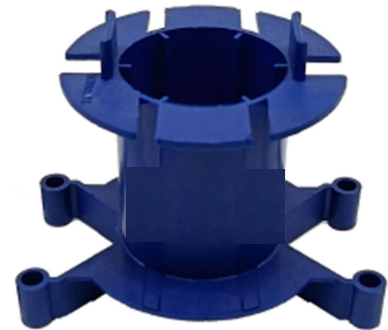
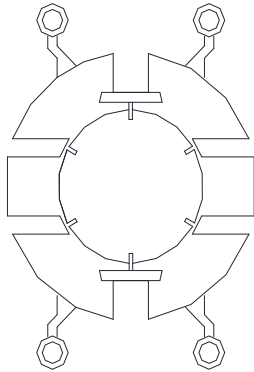
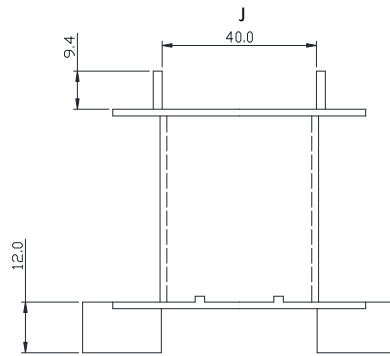
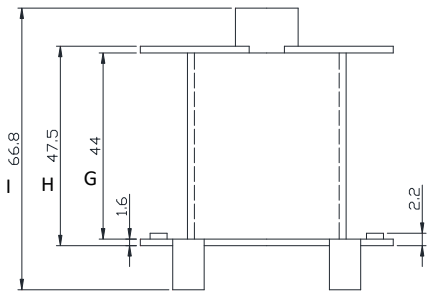
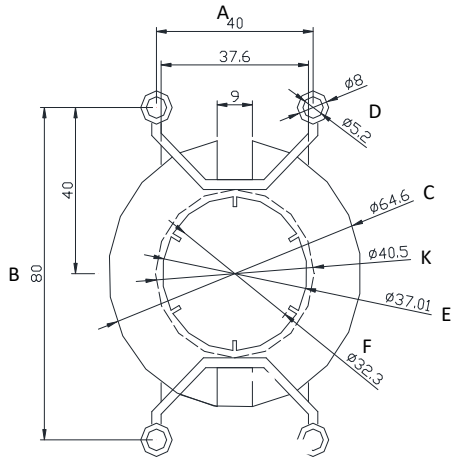

PRODUCT PHOTO

DRAWING	Mico Deng	TOLERANCE		MODEL	PM 87-2		
		0<X<4 ±0.1					
CHECKED APPROVED	CHEN SONGHUA	4<X<16 ±0.2		ANGLE:	TITLE: BOBBIN		
		16<X<63 ±0.5					
		X>63 ±1.0					
ACME Electronics Corporation				UNIT: MM	BOBBIN MATERIAL	PBT (BLUE)	
				SCALE: 1:1	PIN MATERIAL	N/A	
					DATE:	04.12.01	UL 94V-0

CUSTOMER P/N	PM 87 BOBBIN
ACME P/N	AMAOT25506BX-W

版本号REV: 0



2. 材料明细(Material Data):

(1).要求(Description): 供應商長春, 品名PBT, UL號碼E59481
(Supplier : CHANGCHUN, P/N : PBT, UL file number E59481)
(2).实际结果(Result): OK

3. 尺寸测试(Dimension Test):

(1).如附件 “尺寸检测报告”
(Refer to the “Dimension Test Report”)
(2).实际结果(Result): OK

4.外观检查(Visual Inspection):

(1).要求(Description):无明显毛刺,凹陷,熔接线等成型缺陷
(No burrs/flash, sink mark, welding line or other molding defections)
(2).实际结果(Result): OK

5.包装Packaging

一箱包装數量Pack Quantity : 100 pcs
包装重量Pack Weight: 毛重 4.0Kg (34.0g/pcs)

6.最终结论(Conclusion) :

样品测试合格(The samples is ok and can meet the specification).

7.机械尺寸测试Mechanical test (单位Unit:mm)

项目Item	A	B	C	D	E	F	G	H	I	J	K
规格Specification	40.0±0.3	80.0±1.0	64.6±1.0	5.2±0.2	37.01±0.3	32.3±0.3	44.0±0.3	48.0±0.3	66.8±1.0	40.0±0.3	40.5±0.3
公差Tolerance											
样品1Sample1											
样品2Sample2											
样品3Sample3											
样品4Sample4											
样品5Sample5											
样品最小值Min											
样品最大值Max											
Range R差											
样品平均值Average											
项目Item											
规格Specification											
公差Tolerance											
样品1Sample1											
样品2Sample2											
样品3Sample3											
样品4Sample4											
样品5Sample5											
样品最小值Min											
样品最大值Max											
Range R差											
样品平均值Average											

CUSTOMER P/N	PM 87 BOBBIN
ACME P/N	AMAOT25506BX-W

版本号REV: 0