

**ZYNQ UltraScale+
FPGA Development Board
AXU5EVB-P
User Manual**



Version Record

Version	Modify Record
REV1.0	Create Document
REV1.1	Modify Core Board J29 pin definition error

Table of Contents

Version Record	2
Part 1: FPGA Development Board Introduction	7
Part 2: ACU5EV core board	12
Part 2.1: ACU5EV core board Introduction	12
Part 2.2: ZYNQ Chip	13
Part 2.3: DDR4 DRAM	15
Part 2.4: QSPI Flash	22
Part 2.5: eMMC Flash	23
Part 2.6: Clock configuration	25
Part 2.7: LED	27
Part 2.8: Power Supply	28
Part 2.9: ACU5EV Core Board Size Dimension	29
Part 2.10: Board to Board Connectors pin assignment	29
Part 3: Carrier Board	38
Part 3.1: Carrier Board Introduction	38
Part 3.2: M.2 Interface	38
Part 3.3: DP Interface	39
Part 3.4: USB3.0 Interface	41
Part 3.5: Gigabit Ethernet Interface	42
Part 3.6: USB to Serial Port	44
Part 3.7: SD Card Slot Interface	46
Part 3.8: HDMI Output Interface	47
Part 3.9: HDMI Input Interface	48
Part 3.10: SFP Interface	50
Part 3.11: PCIe Slot	51
Part 3.12: CAN Communication Interface	53
Part 3.13: 485 Communication Interface	54

Part 3.14: MIPI Camera Interface	54
Part 3.15: FMC Interface	56
Part 3.16: JTAG Debug Port	59
Part 3.17: Real-time Clock	60
Part 3.18: EEPROM and Temperature Sensor	60
Part 3.19: User LEDs	61
Part 3.20: Keys	62
Part 3.21: DIP Switch Configuration	63
Part 3.22: Power Supply	64
Part 3.23: ALINX Customized Fan	65
Part 3.24: Carrier Board Size Dimension	66

Alinx has officially released the 2019 development board (model: AXU5EVB-P) based on the XILINX Zynq UltraScale+MPSoCs development platform. In order for you to quickly understand this development platform, we have written this user manual.

This MPSoCs FPGA development platform adopts the core board + carrier board mode, which is convenient for users to use the core board for secondary development. The core board uses XILINX Zynq UltraScale+ EV chip ZU5EV solution, uses Processing System(PS)+Programmable Logic(PL) technology to integrate dual-core ARM ARM Cortex-A53 and FPGA programmable logic on a single chip. In addition, the PS side of the core board has 4 pieces of 1GB high-speed DDR4 SDRAM chips, 1 piece of 8GB eMMC memory chip and 1 piece of 256Mb QSPI FLASH chip; the PL side of the core board has 1 piece of 1GB DDR4 SDRAM chip

In the design of carrier board, we have extended a wealth of interfaces for users, such as 1 FMC LPC interface, 1 M.2 Solid-state drive interface, 1 DP interface, 1 PCIe x 2 Interfaces, 2 SFP+ optical interfaces, 4 USB 3.0 Interface, 2 Gigabit Ethernet interfaces, 1 HDMI Input Interface, 1 HDMI Output Interface, 2 Uart Interfaces, 1 SD card slot, 2-Channel CAN bus interfaces, 2-Channel RS485 bus interfaces, 1 MIPI Camera Interface and so on. It meets users' requirements for high-speed data exchange, data storage, Video transmission processing, deep learning, artificial intelligence and industrial control. It is a "professional" ZYNQ development platform. For high-speed data transmission and exchange, pre-verification and post-application of data processing is possible. This product is very suitable for students, engineers and other groups engaged in MPSoCs development.

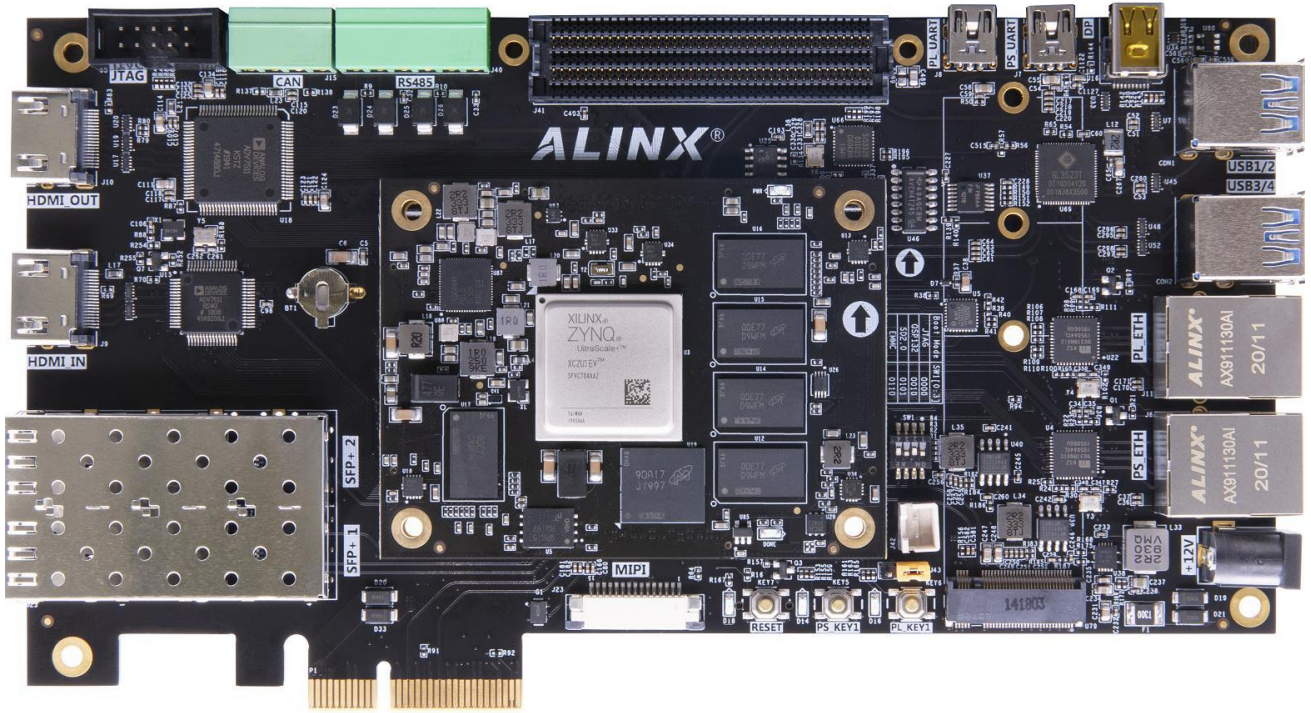

Part 1: FPGA Development Board Introduction

Here, a brief functional introduction is provided to the AXU5EVB-P MPSoCs development platform.

The entire structure of the AXU5EVB-P FPGA development board is inherited from our consistent core board + carrier board model. A high-speed inter-board connector is used between the core board and the carrier board.

The core board is mainly composed of the smallest system of ZU5EV. + 5 DDR4 + eMMC + QSPI FLASH, ZU5EV uses Xilinx's Zynq UltraScale+ MPSoCs EV chip, the model number is XCZU5EV-2SFVC784I. XCZU5EV chip can be divided into processor system part Processor System (PS) and programmable logic part Programmable Logic (PL). On the PS side and PL side of the XCZU5EV chip, there are 4 DDR4 and 1 DDR4 respectively, each with a capacity of up to 1GB, which enables the ARM system and FPGA system to independently process and store data. The 8GB eMMC FLASH memory chip and a 256Mb QSPI FLASH which are on the PS side, used to statically store the operating system, file system and user data of MPSoCs.

The AXU5EVB-P carrier board expands its rich peripheral interface, including 1 M.2 interface, 1 DP interface, 4 USB 3.0 Interface, 2 Gigabit Ethernet interfaces, 1 PCIE X 2 Interface, 2 SFP Interfaces, 2 UART Interfaces, 1 SD card slot, 1 HDMI Input Interface, 1 HDMI Output Interface, 1 FMC Interface, 2-Channel CAN bus interfaces, 2-Channel RS485 bus interfaces, 1 MIPI Camera Interface and some keys and LEDs.

The following figure shows the structure of the entire development system:

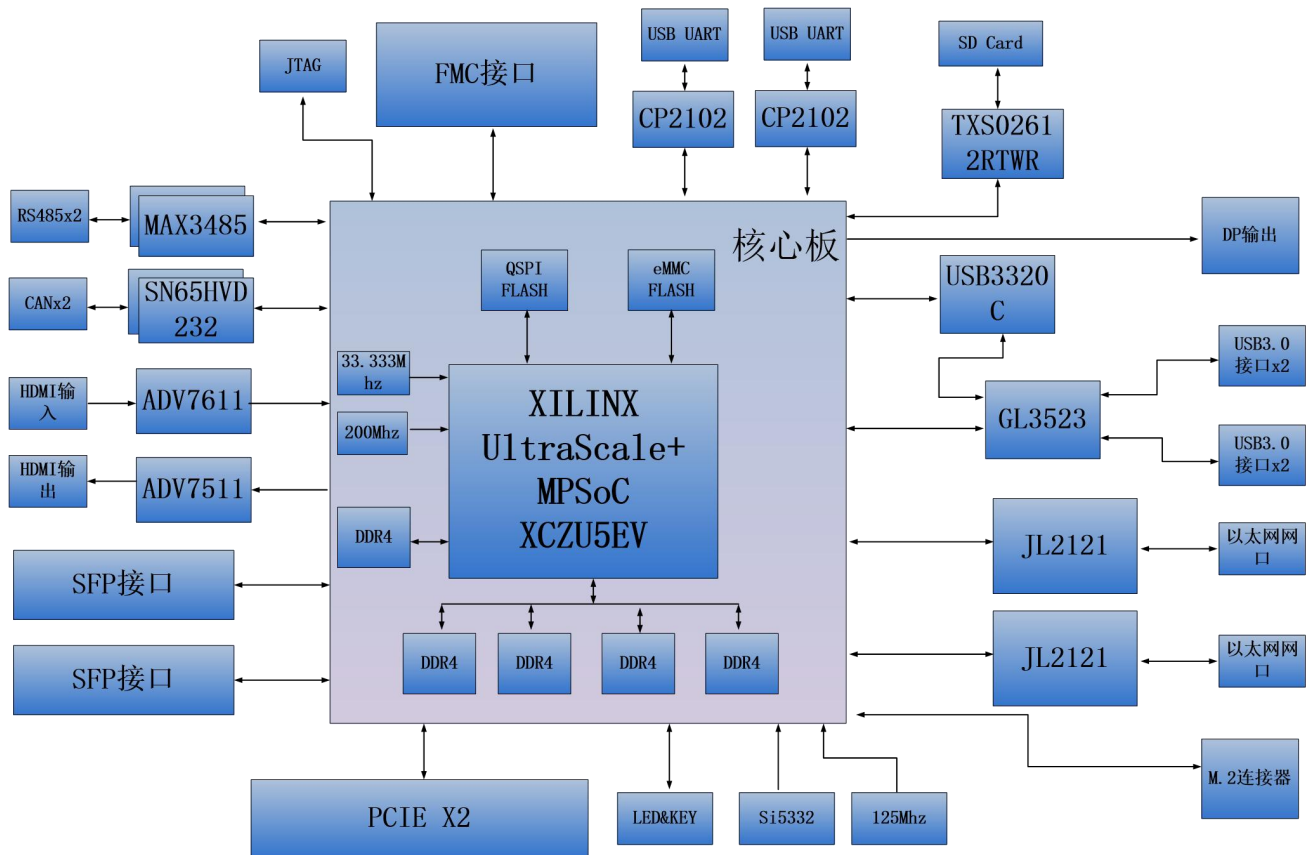

Figure 1-1-1: The Schematic Diagram of the AXU5EVB-P

Through this diagram, you can see the interfaces and functions that the AXU5EVB-P FPGA Development Board contains:

➤ ZU5EV core board

It consists of ZU5EV +4GB DDR4 (PS) +1GB DDR4 (PL) +8GB eMMC FLASH + 256Mb QSPI FLASH, and there are 2 crystal oscillators to provide the clock, a single-ended 33.3333MHz crystal oscillator for the PS system, and a differential 200MHz crystal oscillator for the PL logic DDR reference clock.

➤ M.2 Interface

1 PCIe x1 standard M.2 interface, used to connect M.2 SSD solid state drives, with a communication speed of up to 6Gbps.

➤ DP Output Interface

1 standard Display Port output display interface, used for video image display. Supports up to 4K@30Hz or 1080P@60Hz output

➤ USB 3.0 Interface

4-channel USB3.0 HOST interface, USB interface type is TYPE A. Used to connect external USB peripherals, such as connecting a mouse, keyboard, U disk, etc.

➤ Gigabit Ethernet Interface

2-Channel 10/100M/1000M Ethernet RJ45 interface for Ethernet data exchange with computers or other network devices. The network interface chip uses Micrel's KSZ9031 industrial grade GPHY chip.

➤ USB Uart Interface

2-Channel Uart to USB interfaces for communication with the computer, for user debugging. The serial port chip adopts the USB-UAR chip of Silicon Labs CP2102GM, and the USB interface adopts the MINI USB interface.

➤ PCIe x 2 Interface

It supports the PCI Express 3.0 standard (compatible with 2.0), provides a standard PCIe x2 high-speed data transmission interface, and the single-channel communication rate can be as high as 8GBaud.

➤ 2-Channel SFP Fiber Interface

The two high-speed transceivers of the GTH transceiver are connected to the transmitting and receiving of two optical modules, realizing two high-speed optical fiber communication interfaces. The transmitting and sending speed of each optical fiber data communication is as high as 12.5Gb/s.

➤ SD Card Slot Interface

1 Micro SD card holder, used to store operating system image and file system.

➤ HDMI Output Interface

- 1 HDMI video output interface, using ADV7511 HDMI encoding chip from ANALOG DEVICE, supports up to 1080P@60Hz output and 3D output.
- HDMI Input Interface
 - 1 HDMI video input interface, using ADV7611 HDMI decoding chip from ANALOG DEVICE, supports up to 1080P@60Hz input and supports data input in different formats.
- FMC Expansion Interface
 - 1 standard FMC LPC expansion port, which can be connected to various FMC modules of XILINX or ALINX (HDMI input and output modules, binocular camera modules, high-speed AD modules, etc.).
- CAN Communication Interface
 - Two-way CAN bus interface, using TI's SN65HVD232 chip, the interface uses 4Pin green terminal blocks.
- 485 Communication Interface
 - Two-way 485 communication interface, using MAX3485 chip of MAXIM company. The interface uses 6Pin green terminal blocks.
- MIPI Interface
 - MIPI camera input interfaces, used to connect MIPI camera module (AN5641).
- JTAG debug port
 - A 10-pin 0.1 spacing standard JTAG ports for FPGA program download and debugging. Users can debug and download the ZU4EV system through the XILINX downloader.
- Temperature and humidity sensor chip LM75
 - On-board temperature and humidity sensor chip LM75, used to detect the temperature and humidity of the surrounding environment around the FPGA development board
- EEPROM

One EEPROM 24LC04 with I2C interface

➤ Real Time Clock (RTC)

1 built-in RTC real-time clock

➤ LED Lights

5 LEDs, include 2 LEDs on the core board, 3 LED on the carrier board.

There are 1 power indicator and 1 DONE Configuration indicator on the core board, 1 power indicator on the carrier board. There are 1 power indicator and 2 user indicators on the carrier board.

➤ KEYS

3 KEYS, include 1 Rest KEY and 2 User KEYS.

Part 2: ACU5EV core board

Part 2.1: ACU5EV core board Introduction

ACU5EV (core board model, the same below) FPGA core board, ZYNQ chip is based on XCZU5EV-2SFVC784I of XILINX company Zynq UltraScale+ MPSoCs EV Family.

This core board uses 5 Micron DDR4 chips MT40A512M16GE, of which 4 DDR4 chips are mounted on the PS side to form a 64-bit data bus bandwidth and 4GB capacity. One DDR4 chip is mounted on the PL end, which is a 16-bit data bus width and a capacity of 1GB. The highest operating speed of DDR4 SDRAM on the PS side can reach 1200MHz (data rate 2400Mbps), and the highest operating speed of DDR4 SDRAM on the PL side can reach 1066MHz (data rate 2132Mbps). In addition, a 256MBit QSPI FLASH and an 8GB eMMC FLASH chip are also integrated on the core board to start storage configuration and system files.

In order to connect with the carrier board, the four board-to-board connectors of this core board expand the PS side USB2.0 interface, Gigabit Ethernet interface, SD card interface and other remaining MIO ports; also expand 4 pairs of PS MGT high-speed transceiver interface; and almost all IO ports on the PL side (HP I/O: 96, HD I/O: 84). The wiring between the XCZU5EV chip and the interface has been processed with equal length and differential, and the core board size is only 3.15*2.36 (inch), which is very suitable for secondary development.

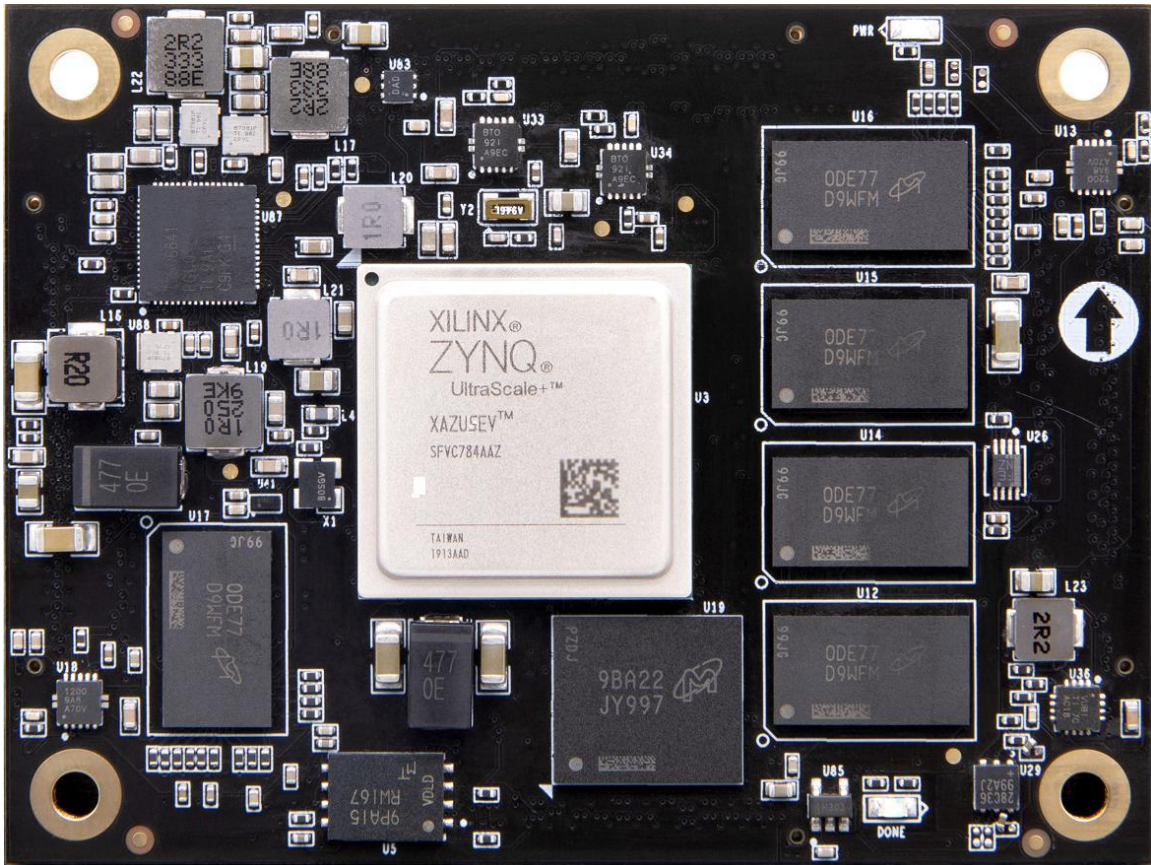

Figure 2-1-1: ACU5EVB-P Core Board (Front View)

Part 2.2: ZYNQ Chip

The FPGA core board ACU5EV uses Xilinx's Zynq UltraScale+ MPSoCs EV family chip, module XCZU5EV-2SFVC784I. The PS system of the ZU5EV chip integrates 4 ARM Cortex™-A53 processors with a speed of up to 1.2Ghz and supports Level 2 Cache; it also contains 2 Cortex-R5 processors with a speed of up to 500Mhz.

The ZU5EV chip supports 32-bit or 64-bit DDR4, LPDDR4, DDR3, DDR3L, LPDDR3 memory chips, with rich high-speed interfaces on the PS side such as PCIE Gen2, USB3.0, SATA 3.1, DisplayPort; it also supports USB2.0 , Gigabit Ethernet, SD/SDIO, I2C, CAN, UART, GPIO and other interfaces. The PL end contains a wealth of programmable logic units, DSP and internal RAM. .

Figure 2-2-1 detailed the Overall Block Diagram of the ZU5EV Chip.

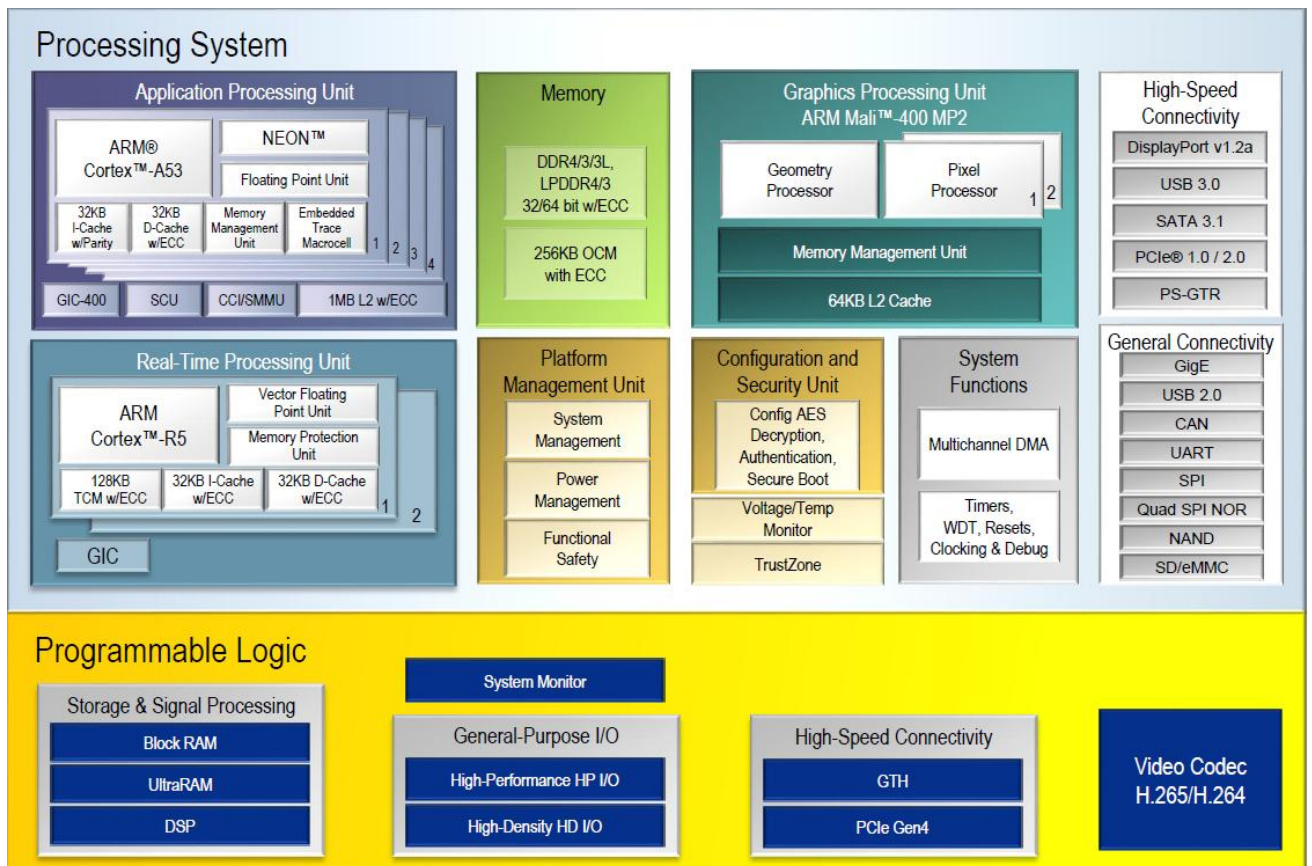

Figure 2-2-1: Overall Block Diagram of the ZYNQ ZU5EV Chip

The main parameters of the PS system part are as follows:

- ARM quad-core Cortex™-A53 processor, speed up to 1.5GHz, each CPU 32KB level 1 instruction and data cache, 1MB level 2 cache, shared by 2 CPUs
- ARM dual-core Cortex-R5 processor, speed up to 600MHz, each CPU 32KB level 1 instruction and data cache, and 128K tightly coupled memory.
- Image Video Processor Mali-400 MP2, speed up to 677MHz, 64KB level 2 cache
- External storage interface, support 32/64bit DDR4/3/3L, LPDDR4/3 interface
- Static storage interface, support NAND, 2xQuad-SPI FLASH.

- High-speed connection interface, support PCIe Gen2 x 4, 2 x USB3.0, Sata 3.1, Display Port, 4 x Tri-mode Gigabit Ethernet
- Common connection interfaces: 2 x USB2.0, 2 x SD/SDIO, 2 x UART, 2 x CAN 2.0B, 2 x I2C, 2 x SPI, 4 x 32b GPIO
- Power management: Support the four-part division of power supply Full/ Low/ PL/ Battery
- Encryption algorithm: support RSA, AES and SHA.
- System monitoring: 10-bit 1Mbps AD sampling for temperature and voltage detection.

The main parameters of the PL logic part are as follows:

- System Logic Cells: 256.2K
- CLB Flip-flops: 234.24K
- Look-up-tables (LUTs): 117.12K
- Block RAM: 5.1 Mb
- Clock Management Units (CMTs): 4
- DSP Slices: 1248
- Video Codec Unit (VCU): 1
- PCIE3.0: 2
- GTH 12.5Gb/s Transceiver: 4

XCZU5EV-2SFVC784I chip speed grade is -2, industrial grade, package is SFVC784

Part 2.3: DDR4 DRAM

The ACU5EV core board is equipped with 5 Micron (Micron) 1GB DDR4 chips, model MT40A512M16LY-062E, of which 4 DDR4 chips are mounted on the PS side to form a 64-bit data bus bandwidth and 4GB capacity. One DDR4

chip is mounted on the PL end, which is a 16-bit data bus width and a capacity of 1GB. The maximum operating speed of the DDR4 SDRAM on the PS side can reach 1200MHz (data rate 2400Mbps), and the 4 DDR4 storage systems are directly connected to the memory interface of the PS BANK504. The highest operating speed of the DDR4 SDRAM on the PL side can reach 1066MHz (data rate 2133Mbps), and a piece of DDR4 is connected to the BANK64 interface of the FPGA. The specific configuration of DDR4 SDRAM is shown in Table 2-3-1 below:

Bit Number	Chip Model	Capacity	Manufacturer
U12,U14,U15,U16	MT40A512M16LY-062E	512M x 16bit	Micron

Table 2-3-1: DDR4 SDRAM Configuration

The hardware design of DDR4 requires strict consideration of signal integrity. We have fully considered the matching resistor/terminal resistance, trace impedance control, and trace length control in circuit design and PCB design to ensure high-speed and stable operation of DDR4.

The hardware connection of DDR4 SDRAM on the PS Side is shown in Figure 2-3-1:

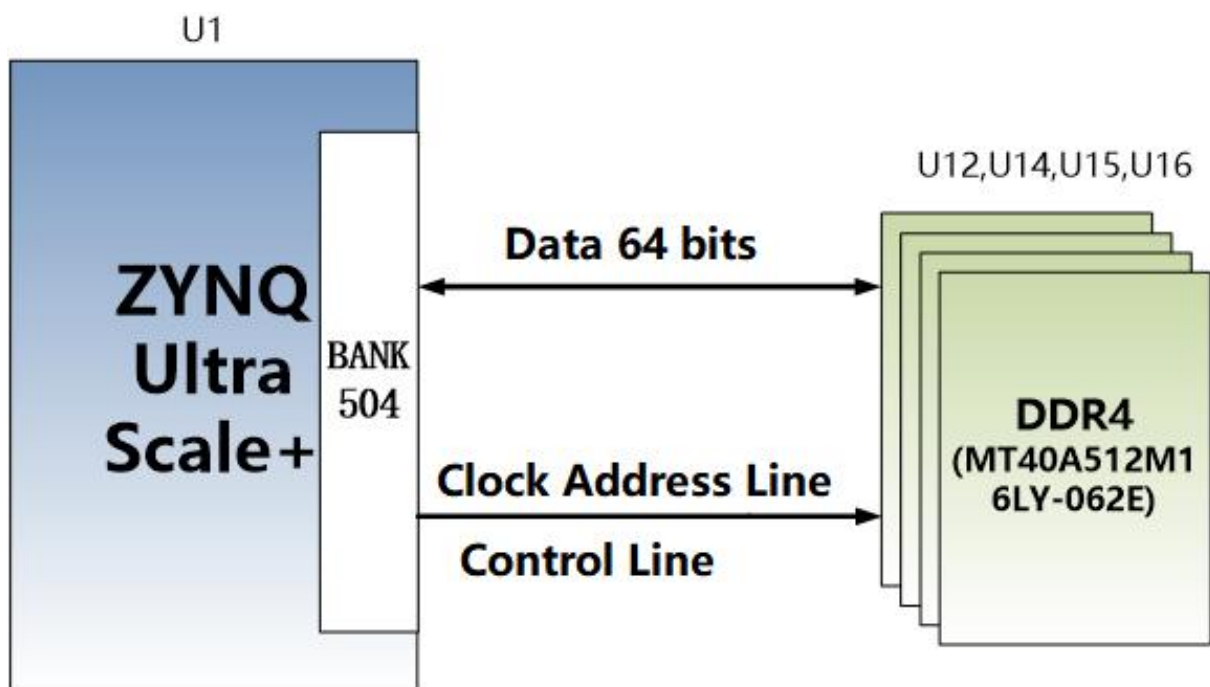

Figure 2-3-1: PS DDR4 DRAM schematic diagram

The hardware connection of DDR4 SDRAM on the PL Side is shown in Figure 2-3-2:

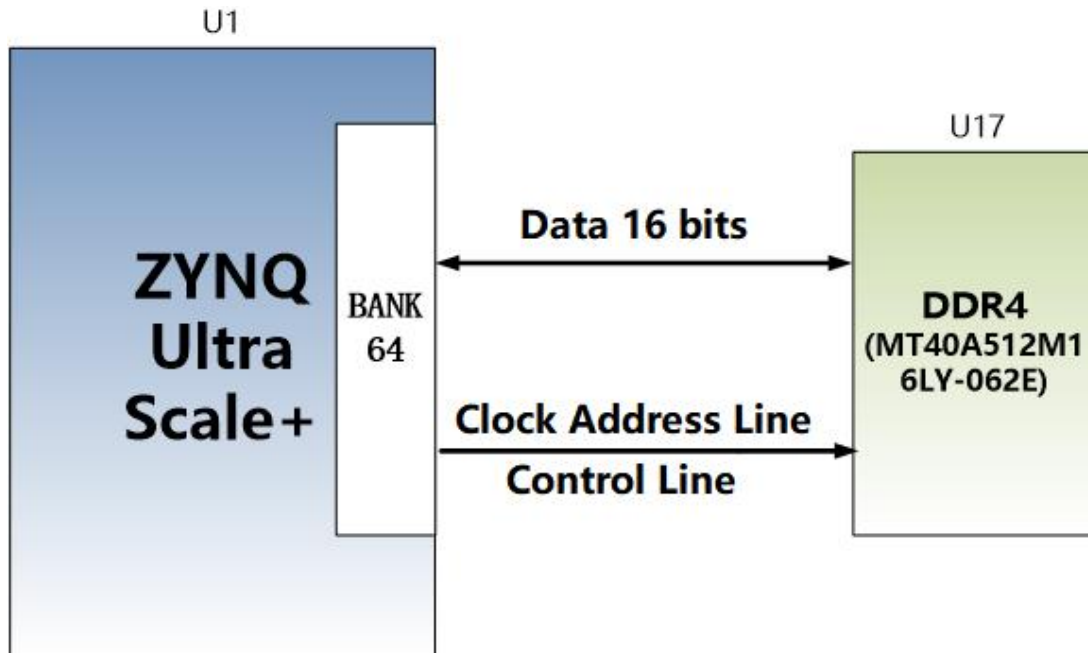

Figure 2-3-2: PL DDR4 DRAM schematic diagram

PS Side DDR4 SDRAM pin assignment:

Signal Name	Pin Name	Pin Number
PS_DDR4_DQS0_P	PS_DDR_DQS_P0_504	AF21
PS_DDR4_DQS0_N	PS_DDR_DQS_N0_504	AG21
PS_DDR4_DQS1_P	PS_DDR_DQS_P1_504	AF23
PS_DDR4_DQS1_N	PS_DDR_DQS_N1_504	AG23
PS_DDR4_DQS2_P	PS_DDR_DQS_P2_504	AF25
PS_DDR4_DQS2_N	PS_DDR_DQS_N2_504	AF26
PS_DDR4_DQS3_P	PS_DDR_DQS_P3_504	AE27
PS_DDR4_DQS3_N	PS_DDR_DQS_N3_504	AF27
PS_DDR4_DQS4_P	PS_DDR_DQS_P4_504	N23
PS_DDR4_DQS4_N	PS_DDR_DQS_N4_504	M23
PS_DDR4_DQS5_P	PS_DDR_DQS_P5_504	L23
PS_DDR4_DQS5_N	PS_DDR_DQS_N5_504	K23
PS_DDR4_DQS6_P	PS_DDR_DQS_P6_504	N26

PS_DDR4_DQS6_N	PS_DDR_DQS_N6_504	N27
PS_DDR4_DQS7_P	PS_DDR_DQS_P7_504	J26
PS_DDR4_DQS7_N	PS_DDR_DQS_N7_504	J27
PS_DDR4_DQ0	PS_DDR_DQ0_504	AD21
PS_DDR4_DQ1	PS_DDR_DQ1_504	AE20
PS_DDR4_DQ2	PS_DDR_DQ2_504	AD20
PS_DDR4_DQ3	PS_DDR_DQ3_504	AF20
PS_DDR4_DQ4	PS_DDR_DQ4_504	AH21
PS_DDR4_DQ5	PS_DDR_DQ5_504	AH20
PS_DDR4_DQ6	PS_DDR_DQ6_504	AH19
PS_DDR4_DQ7	PS_DDR_DQ7_504	AG19
PS_DDR4_DQ8	PS_DDR_DQ8_504	AF22
PS_DDR4_DQ9	PS_DDR_DQ9_504	AH22
PS_DDR4_DQ10	PS_DDR_DQ10_504	AE22
PS_DDR4_DQ11	PS_DDR_DQ11_504	AD22
PS_DDR4_DQ12	PS_DDR_DQ12_504	AH23
PS_DDR4_DQ13	PS_DDR_DQ13_504	AH24
PS_DDR4_DQ14	PS_DDR_DQ14_504	AE24
PS_DDR4_DQ15	PS_DDR_DQ15_504	AG24
PS_DDR4_DQ16	PS_DDR_DQ16_504	AC26
PS_DDR4_DQ17	PS_DDR_DQ17_504	AD26
PS_DDR4_DQ18	PS_DDR_DQ18_504	AD25
PS_DDR4_DQ19	PS_DDR_DQ19_504	AD24
PS_DDR4_DQ20	PS_DDR_DQ20_504	AG26
PS_DDR4_DQ21	PS_DDR_DQ21_504	AH25
PS_DDR4_DQ22	PS_DDR_DQ22_504	AH26
PS_DDR4_DQ23	PS_DDR_DQ23_504	AG25
PS_DDR4_DQ24	PS_DDR_DQ24_504	AH27
PS_DDR4_DQ25	PS_DDR_DQ25_504	AH28
PS_DDR4_DQ26	PS_DDR_DQ26_504	AF28
PS_DDR4_DQ27	PS_DDR_DQ27_504	AG28
PS_DDR4_DQ28	PS_DDR_DQ28_504	AC27
PS_DDR4_DQ29	PS_DDR_DQ29_504	AD27
PS_DDR4_DQ30	PS_DDR_DQ30_504	AD28

PS_DDR4_DQ31	PS_DDR_DQ31_504	AC28
PS_DDR4_DQ32	PS_DDR_DQ32_504	T22
PS_DDR4_DQ33	PS_DDR_DQ33_504	R22
PS_DDR4_DQ34	PS_DDR_DQ34_504	P22
PS_DDR4_DQ35	PS_DDR_DQ35_504	N22
PS_DDR4_DQ36	PS_DDR_DQ36_504	T23
PS_DDR4_DQ37	PS_DDR_DQ37_504	P24
PS_DDR4_DQ38	PS_DDR_DQ38_504	R24
PS_DDR4_DQ39	PS_DDR_DQ39_504	N24
PS_DDR4_DQ40	PS_DDR_DQ40_504	H24
PS_DDR4_DQ41	PS_DDR_DQ41_504	J24
PS_DDR4_DQ42	PS_DDR_DQ42_504	M24
PS_DDR4_DQ43	PS_DDR_DQ43_504	K24
PS_DDR4_DQ44	PS_DDR_DQ44_504	J22
PS_DDR4_DQ45	PS_DDR_DQ45_504	H22
PS_DDR4_DQ46	PS_DDR_DQ46_504	K22
PS_DDR4_DQ47	PS_DDR_DQ47_504	L22
PS_DDR4_DQ48	PS_DDR_DQ48_504	M25
PS_DDR4_DQ49	PS_DDR_DQ49_504	M26
PS_DDR4_DQ50	PS_DDR_DQ50_504	L25
PS_DDR4_DQ51	PS_DDR_DQ51_504	L26
PS_DDR4_DQ52	PS_DDR_DQ52_504	K28
PS_DDR4_DQ53	PS_DDR_DQ53_504	L28
PS_DDR4_DQ54	PS_DDR_DQ54_504	M28
PS_DDR4_DQ55	PS_DDR_DQ55_504	N28
PS_DDR4_DQ56	PS_DDR_DQ56_504	J28
PS_DDR4_DQ57	PS_DDR_DQ57_504	K27
PS_DDR4_DQ58	PS_DDR_DQ58_504	H28
PS_DDR4_DQ59	PS_DDR_DQ59_504	H27
PS_DDR4_DQ60	PS_DDR_DQ60_504	G26
PS_DDR4_DQ61	PS_DDR_DQ61_504	G25
PS_DDR4_DQ62	PS_DDR_DQ62_504	K25
PS_DDR4_DQ63	PS_DDR_DQ63_504	J25
PS_DDR4_DM0	PS_DDR_DM0_504	AG20

PS_DDR4_DM1	PS_DDR_DM1_504	AE23
PS_DDR4_DM2	PS_DDR_DM2_504	AE25
PS_DDR4_DM3	PS_DDR_DM3_504	AE28
PS_DDR4_DM4	PS_DDR_DM4_504	R23
PS_DDR4_DM5	PS_DDR_DM5_504	H23
PS_DDR4_DM6	PS_DDR_DM6_504	L27
PS_DDR4_DM7	PS_DDR_DM7_504	H26
PS_DDR4_A0	PS_DDR_A0_504	W28
PS_DDR4_A1	PS_DDR_A1_504	Y28
PS_DDR4_A2	PS_DDR_A2_504	AB28
PS_DDR4_A3	PS_DDR_A3_504	AA28
PS_DDR4_A4	PS_DDR_A4_504	Y27
PS_DDR4_A5	PS_DDR_A5_504	AA27
PS_DDR4_A6	PS_DDR_A6_504	Y22
PS_DDR4_A7	PS_DDR_A7_504	AA23
PS_DDR4_A8	PS_DDR_A8_504	AA22
PS_DDR4_A9	PS_DDR_A9_504	AB23
PS_DDR4_A10	PS_DDR_A10_504	AA25
PS_DDR4_A11	PS_DDR_A11_504	AA26
PS_DDR4_A12	PS_DDR_A12_504	AB25
PS_DDR4_A13	PS_DDR_A13_504	AB26
PS_DDR4_WE_B	PS_DDR_A14_504	AB24
PS_DDR4_CAS_B	PS_DDR_A15_504	AC24
PS_DDR4_RAS_B	PS_DDR_A16_504	AC23
PS_DDR4_ACT_B	PS_DDR_ACT_N_504	Y23
PS_DDR4_ALERT_B	PS_DDR_ALERT_N_504	U25
PS_DDR4_BA0	PS_DDR_BA0_504	V23
PS_DDR4_BA1	PS_DDR_BA1_504	W22
PS_DDR4_BG0	PS_DDR_BG0_504	W24
PS_DDR4_CS0_B	PS_DDR_CS_N0_504	W27
PS_DDR4_ODT0	PS_DDR_ODT0_504	U28
PS_DDR4_PARITY	PS_DDR_PARITY_504	V24
PS_DDR4_RESET_B	PS_DDR_RST_N_504	U23
PS_DDR4_CLK0_P	PS_DDR_CK0_P_504	W25

PS_DDR4_CLK0_N	PS_DDR_CK0_N_504	W26
PS_DDR4_CKE0	PS_DDR_CKE0_504	V28

PL Side DDR4 SDRAM pin assignment:

Signal Name	Pin Name	Pin Number
PL_DDR4_DQS0_P	IO_L22P_T3U_N6_DBC_AD0P_64	AE2
PL_DDR4_DQS0_N	IO_L22N_T3U_N7_DBC_AD0N_64	AF2
PL_DDR4_DQS1_P	IO_L16P_T2U_N6_QBC_AD3P_64	AD2
PL_DDR4_DQS1_N	IO_L16N_T2U_N7_QBC_AD3N_64	AD1
PL_DDR4_DQ0	IO_L24N_T3U_N11_64	AG1
PL_DDR4_DQ1	IO_L24P_T3U_N10_64	AF1
PL_DDR4_DQ2	IO_L23N_T3U_N9_64	AH1
PL_DDR4_DQ3	IO_L23P_T3U_N8_64	AH2
PL_DDR4_DQ4	IO_L21N_T3L_N5_AD8N_64	AF3
PL_DDR4_DQ5	IO_L21P_T3L_N4_AD8P_64	AE3
PL_DDR4_DQ6	IO_L20N_T3L_N3_AD1N_64	AH3
PL_DDR4_DQ7	IO_L20P_T3L_N2_AD1P_64	AG3
PL_DDR4_DQ8	IO_L18N_T2U_N11_AD2N_64	AC1
PL_DDR4_DQ9	IO_L18P_T2U_N10_AD2P_64	AB1
PL_DDR4_DQ10	IO_L17N_T2U_N9_AD10N_64	AC2
PL_DDR4_DQ11	IO_L17P_T2U_N8_AD10P_64	AB2
PL_DDR4_DQ12	IO_L15N_T2L_N5_AD11N_64	AB3
PL_DDR4_DQ13	IO_L15P_T2L_N4_AD11P_64	AB4
PL_DDR4_DQ14	IO_L14N_T2L_N3_GC_64	AC3
PL_DDR4_DQ15	IO_L14P_T2L_N2_GC_64	AC4
PL_DDR4_DM0	IO_L19P_T3L_N0_DBC_AD9P_64	AG4
PL_DDR4_DM1	IO_L13P_T2L_N0_GC_QBC_64	AD5
PL_DDR4_A0	IO_L8N_T1L_N3_AD5N_64	AG8
PL_DDR4_A1	IO_L3P_T0L_N4_AD15P_64	AB8
PL_DDR4_A2	IO_L8P_T1L_N2_AD5P_64	AF8
PL_DDR4_A3	IO_L3N_T0L_N5_AD15N_64	AC8
PL_DDR4_A4	IO_L11P_T1U_N8_GC_64	AF7
PL_DDR4_A5	IO_L4P_T0U_N6_DBC_AD7P_64	AD7
PL_DDR4_A6	IO_L9N_T1L_N5_AD12N_64	AH7

PL_DDR4_A7	IO_L2P_T0L_N2_64	AE9
PL_DDR4_A8	IO_L9P_T1L_N4_AD12P_64	AH8
PL_DDR4_A9	IO_L1P_T0L_N0_DBC_64	AC9
PL_DDR4_A10	IO_L4N_T0U_N7_DBC_AD7N_64	AE7
PL_DDR4_A11	IO_L7N_T1L_N1_QBC_AD13N_64	AH9
PL_DDR4_A12	IO_L6N_T0U_N11_AD6N_64	AC6
PL_DDR4_A13	IO_L1N_T0L_N1_DBC_64	AD9
PL_DDR4_BA0	IO_T1U_N12_64	AH6
PL_DDR4_BA1	IO_L5N_T0U_N9_AD14N_64	AC7
PL_DDR4_RAS_B	IO_T2U_N12_64	AB5
PL_DDR4_CAS_B	IO_L5P_T0U_N8_AD14P_64	AB7
PL_DDR4_WE_B	IO_L11N_T1U_N9_GC_64	AF6
PL_DDR4_ACT_B	IO_L13N_T2L_N1_GC_QBC_64	AD4
PL_DDR4_CS_B	IO_L6P_T0U_N10_AD6P_64	AB6
PL_DDR4_BG0	IO_L2N_T0L_N3_64	AE8
PL_DDR4_RST	IO_L7P_T1L_N0_QBC_AD13P_64	AG9
PL_DDR4_CLK_N	IO_L10N_T1U_N7_QBC_AD4N_64	AG5
PL_DDR4_CLK_P	IO_L10P_T1U_N6_QBC_AD4P_64	AG6
PL_DDR4_CKE	IO_T3U_N12_64	AE4
PL_DDR4_OTD	IO_L19N_T3L_N1_DBC_AD9N_64	AH4

Part 2.4: QSPI Flash

The FPGA core board ACU5EVB-P is equipped with one 256MBit Quad-SPI FLASH chip to form an 8-bit bandwidth data bus, the flash model is MT25QU256ABA1EW9, which uses the 1.8V CMOS voltage standard. Due to the non-volatile nature of QSPI FLASH, it can be used as a boot device for the system to store the boot image of the system. These images mainly include FPGA bit files, ARM application code, and other user data files. The specific models and related parameters of QSPI FLASH are shown in Table 2-4-1.

Bit Number	Model	Capacity	Manufacturer
U5	MT25QU256ABA1EW9	256Mbit	Winbond

Table 2-4-1: QSPI FLASH Specification

QSPI FLASH is connected to the GPIO port of the BANK500 in the PS section of the ZYNQ chip. In the system design, the GPIO port functions of these PS ports need to be configured as the QSPI FLASH interface. Figure 2-4-1 shows the QSPI Flash in the schematic.

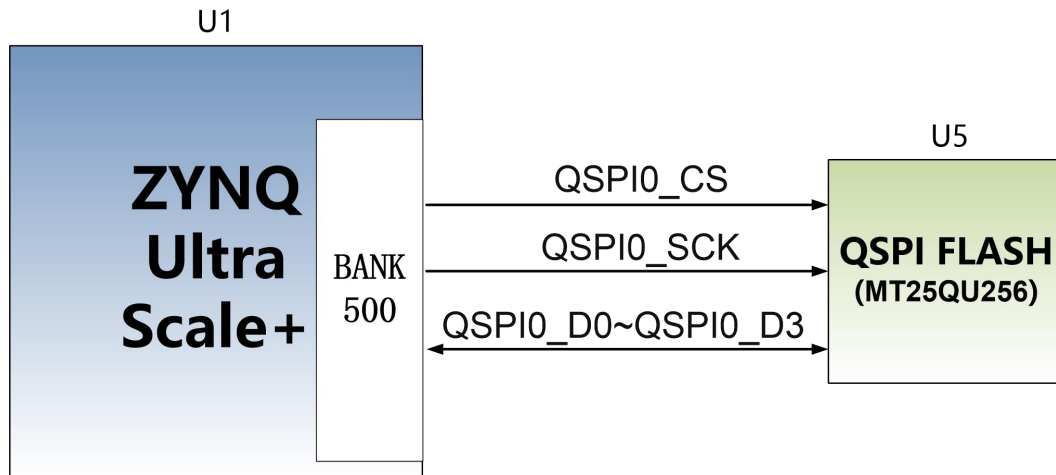

Figure 2-4-1: QSPI Flash in the schematic

Configure chip pin assignments:

Signal Name	Pin Name	Pin Number
MIO0_QSPI0_SCLK	PS_MIO0_500	AG15
MIO1_QSPI0_IO1	PS_MIO1_500	AG16
MIO2_QSPI0_IO2	PS_MIO2_500	AF15
MIO3_QSPI0_IO3	PS_MIO3_500	AH15
MIO4_QSPI0_IO0	PS_MIO4_500	AH16
MIO5_QSPI0_SS_B	PS_MIO5_500	AD16

Part 2.5: eMMC Flash

The ACU5EVB-P core board is equipped with a large-capacity 8GB eMMC FLASH chip, the model is MTFC8GAKAJCN-4M, it supports the HS-MMC interface of the JEDEC e-MMC V5.0 standard, and the level supports 1.8V or 3.3V. The data width of eMMC FLASH and ZYNQ connection is 8bit. Due to the large-capacity and non-volatile characteristics of eMMC FLASH, it can be used as a large-capacity storage device in the ZYNQ system, such as storing ARM applications, system files and other user data files. The specific models and

related parameters of eMMC FLASH are shown in Table 2-5-1.

Bit Number	Model	Capacity	Manufacturer
U19	MTFC8GAKAJCN-4M	8G Byte	Micron

Table 2-5-1: eMMC FLASH Specification

The eMMC FLASH is connected to the GPIO port of the BANK500 of the PS part of the ZYNQ UltraScale+. In the system design, it is necessary to configure the GPIO port function of the PS side as an EMMC interface. Figure 2-5-1 shows the part of eMMC Flash in the schematic diagram.

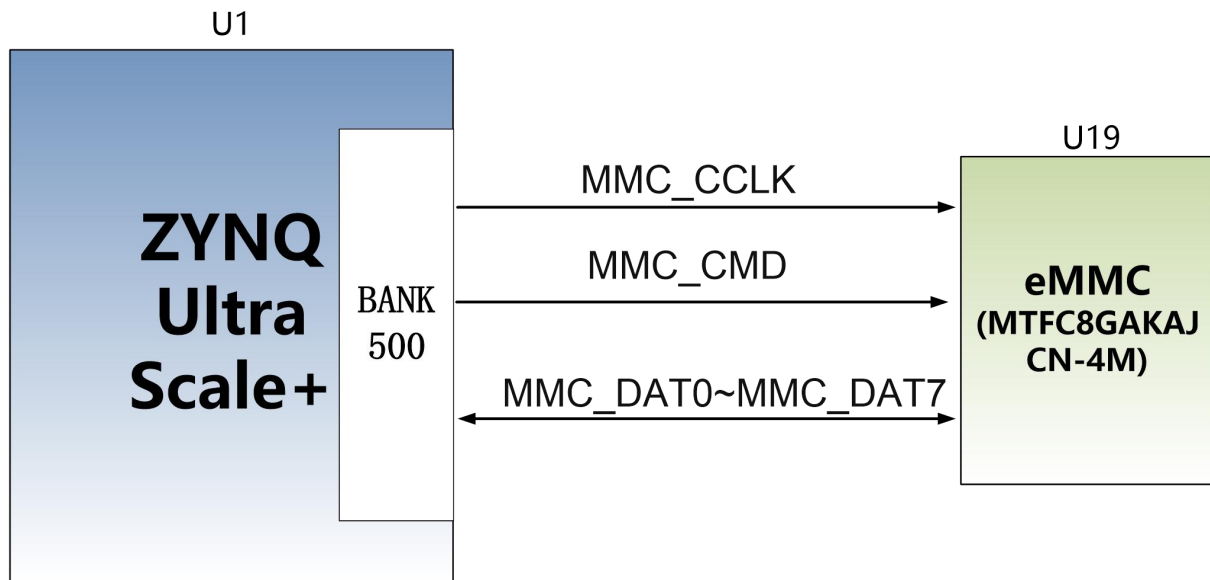

Figure 2-5-1: QSPI Flash in the schematic

Configuration Chip pin assignment:

Signal Name	Pin Name	Pin Number
MIO0_QSPI0_SCLK	PS_MIO0_500	AG15
MIO1_QSPI0_IO1	PS_MIO1_500	AG16
MIO2_QSPI0_IO2	PS_MIO2_500	AF15
MIO3_QSPI0_IO3	PS_MIO3_500	AH15
MIO4_QSPI0_IO0	PS_MIO4_500	AH16
MIO5_QSPI0_SS_B	PS_MIO5_500	AD16

Part 2.6: Clock configuration

The core board provides reference clock and RTC real-time clock for PS system and PL logic respectively, so that PS system and PL logic can work independently. The schematic diagram of the clock circuit design is shown in Figure 2-6-1:

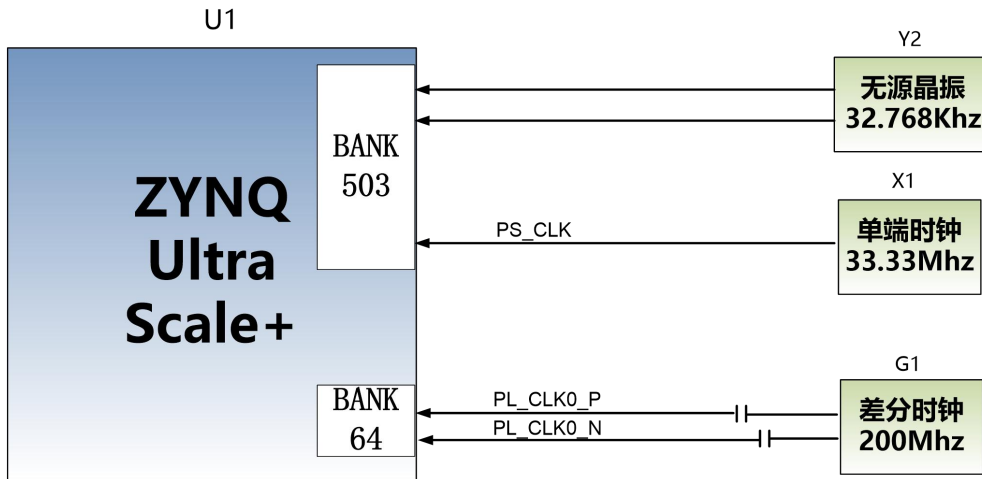

Figure 2-6-1: Core Board Clock Source

PS System RTC Real Time Clock

The passive crystal Y2 on the core board provides a 32.768KHz real-time clock source for the PS system. The crystal is connected to the PS_PADI_503 and PS_PADO_503 pins of BANK503 of the ZYNQ chip. The schematic diagram is shown in Figure 2-6-2:

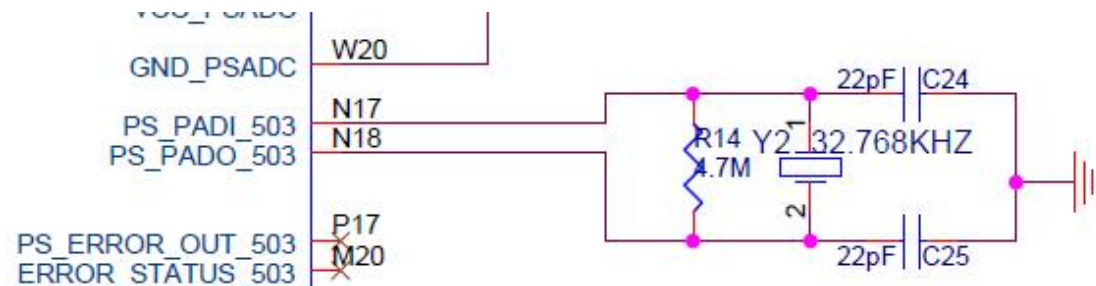

Figure 2-6-2: Passive Crystal Oscillator for RTC

Clock pin assignment:

Signal Name	Pin
PS_PADI_503	N17
PS_PADO_503	N18

PS System Clock Source

The X1 crystal on the core board provides a 33.333MHz clock input for the PS part. The clock input is connected to the PS_REF_CLK_503 pin of BANK503 of the ZYNQ chip. The schematic diagram is shown in Figure 2-6-3:

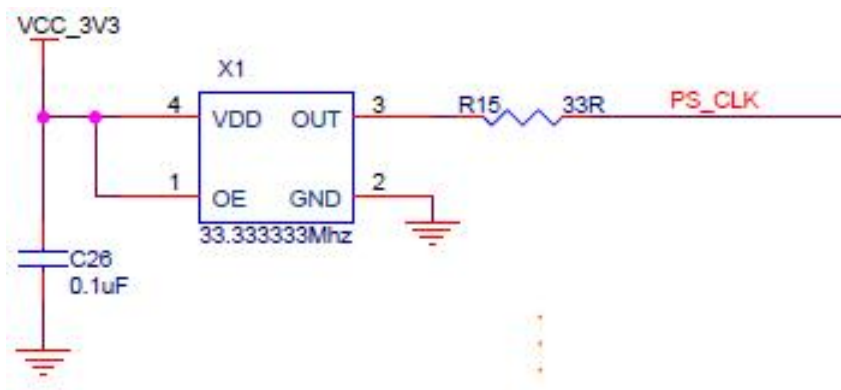

Figure 2-6-3: Active Crystal in PS part

Clock pin assignment:

Signal Name	Pin
PS_CLK	R16

PL System Clock Source

The core board provides a differential 200MHz PL system clock source for the reference clock of the DDR4 controller. The crystal oscillator output is connected to the global clock (MRCC) of PL BANK64. This global clock can be used to drive the DDR4 controller and user logic circuits in the FPGA. The schematic diagram of this clock source is shown in Figure 2-6-4

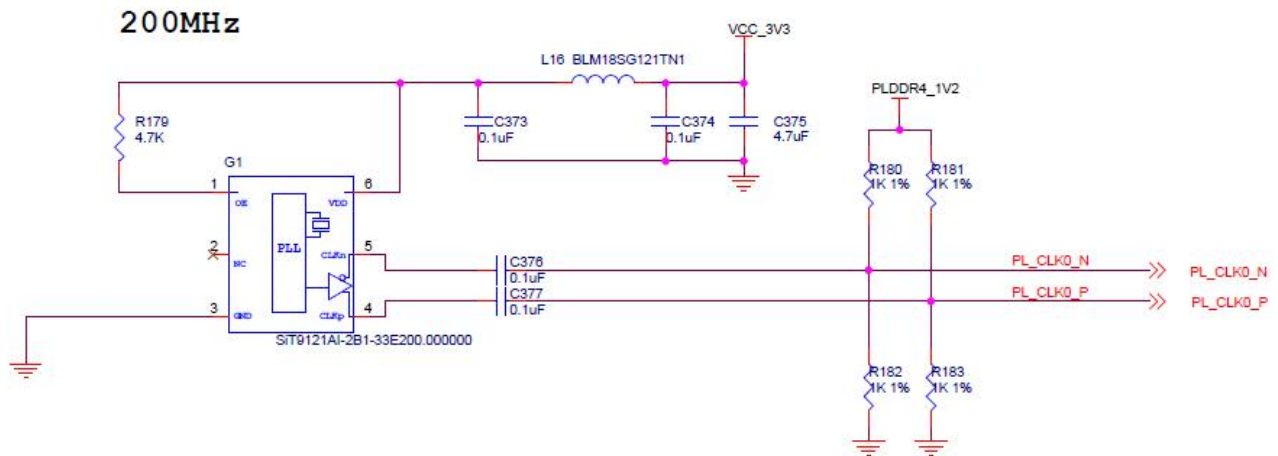

Figure 2-6-4: PL system clock source

Clock pin assignment:

Signal Name	Pin
PL_CLK0_P	AE5
PL_CLK0_N	AF5

Part 2.7: LED

There is a red power indicator (PWR) and a configuration LED (DONE) on the ACU5EVB-P core board. When the core board is powered on, the power indicator will light up; after the FPGA configuration program, the configuration LED light will light up. The LED Schematic in the Core Board is shown in Figure 2-7-1:

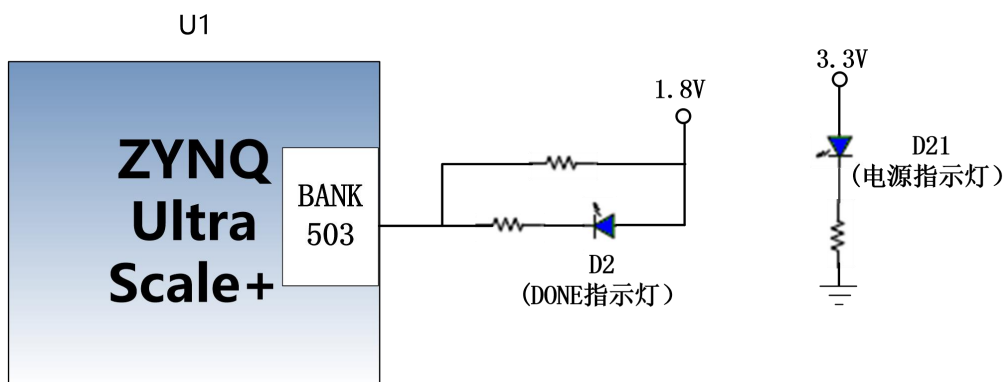
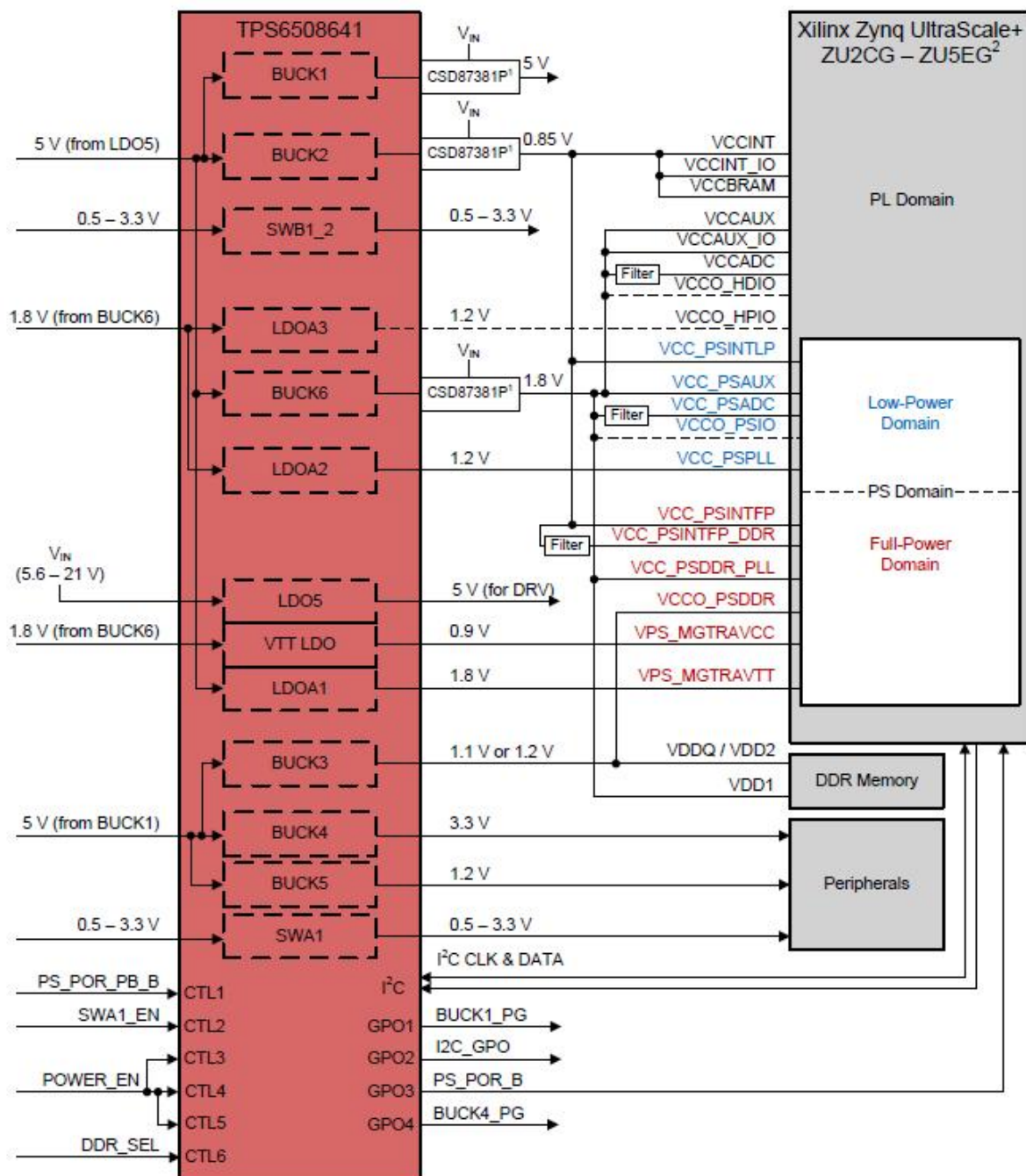

Figure 2-7-1: LED Schematic in the Core Board

Part 2.8: Power Supply

The power supply voltage of the ACU5EVB-P core board is DC12V, which is supplied by connecting the carrier board. The core board uses a PMIC chip TPS6508641 to generate all the power required by the XCZU5EV chip. For the TPS6508641 power supply design, please refer to the power supply chip manual. The design block diagram is as follows:



In addition, the VCCIO power supply of BANK65 and BANK66 of

XCZU5EV chip is provided by the carrier board, which is convenient for users to modify, but the maximum power supply cannot exceed 1.8V.

Part 2.9: ACU5EVB-P Core Board Size Dimension

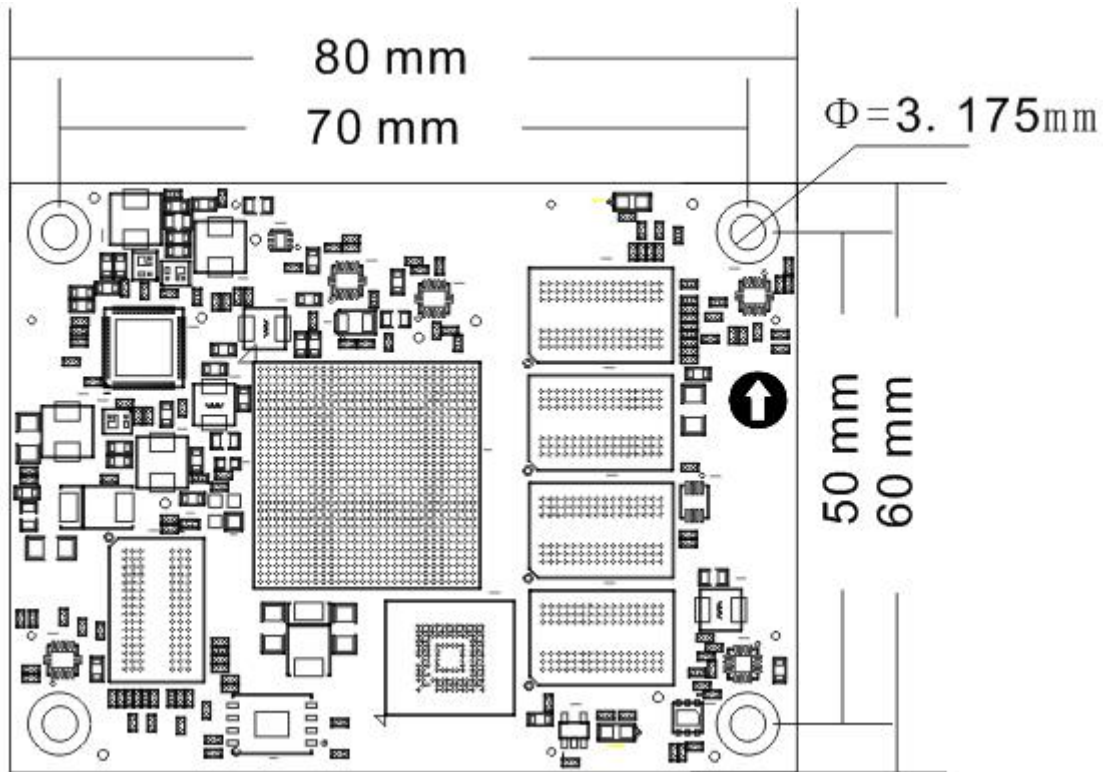

Figure 2-9-1: ACU5EVB-P Core Board Size Dimension

Part 2.10: Board to Board Connectors pin assignment

The core board has a total of four high-speed expansion ports. It uses four 120-pin inter-board connectors (J29/J30/J31/J32) to connect to the carrier board.

The connectors used is Panasonic AXK5A2137YG, and the corresponding connector model in the carrier board is Panasonic AXK6A2337YG. Among them, J29 is connected to the IO of BANK65 and BANK66, J30 is connected to the IO of BANK45, BANK46, BANK66 and the transceiver signal of BANK505 MGT, J31 is connected to the IO of BANK43 and BANK44, J32 is connected to the MIO, VCCO_65, VCCO_66 and +12V power supply of PS.

Among them, the IO level standard of BANK43~46 is 3.3V, and the level standard of BANK65 and BANK66 is determined by the VCCO_65 and VCCO_66 power supply of the carrier board, but cannot exceed +1.8V; the level standard of MIO is also 1.8V.

Pin assignment of board to board connector J29

J29 Pin	Signal Name	Pin No.	J29 Pin	Signal Name	Pin No.
1	B65_L2_N	V9	2	B65_L22_P	K8
3	B65_L2_P	U9	4	B65_L22_N	K7
5	GND	-	6	GND	-
7	B65_L4_N	T8	8	B65_L20_P	J6
9	B65_L4_P	R8	10	B65_L20_N	H6
11	GND	-	12	GND	-
13	B65_L1_N	Y8	14	B65_L6_N	T6
15	B65_L1_P	W8	16	B65_L6_P	R6
17	GND	-	18	GND	-
19	B65_L7_P	L1	20	B65_L17_P	N9
21	B65_L7_N	K1	22	B65_L17_N	N8
23	GND	-	24	GND	-
25	B65_L15_P	N7	26	B65_L9_P	K2
27	B65_L15_N	N6	28	B65_L9_N	J2
29	GND	-	30	GND	-
31	B65_L16_P	P7	32	B65_L3_N	V8
33	B65_L16_N	P6	34	B65_L3_P	U8
35	GND	-	36	GND	-
37	B65_L14_P	M6	38	B65_L19_P	J5
39	B65_L14_N	L5	40	B65_L19_N	J4
41	GND	-	42	GND	-
43	B65_L5_N	T7	44	B65_L18_P	M8
45	B65_L5_P	R7	46	B65_L18_N	L8
47	GND	-	48	GND	-
49	B65_L11_N	K3	50	B65_L8_P	J1
51	B65_L11_P	K4	52	B65_L8_N	H1
53	GND	-	54	GND	-
55	B65_L10_N	H3	56	B65_L24_N	H8
57	B65_L10_P	H4	58	B65_L24_P	H9

59	GND	-	60	GND	-
61	B66_L3_P	F2	62	B65_L12_P	L3
63	B66_L3_N	E2	64	B65_L12_N	L2
65	GND	-	66	GND	-
67	B66_L1_P	G1	68	B65_L13_N	L6
69	B66_L1_N	F1	70	B65_L13_P	L7
71	GND	-	72	GND	-
73	B66_L6_P	G5	74	B65_L21_P	J7
75	B66_L6_N	F5	76	B65_L21_N	H7
77	GND	-	78	GND	-
79	B66_L16_P	G8	80	B65_L23_P	K9
81	B66_L16_N	F7	82	B65_L23_N	J9
83	GND	-	84	GND	-
85	B66_L15_P	G6	86	B66_L5_N	E3
87	B66_L15_N	F6	88	B66_L5_P	E4
89	GND	-	90	GND	-
91	B66_L4_P	G3	92	B66_L2_P	E1
93	B66_L4_N	F3	94	B66_L2_N	D1
95	GND	-	96	GND	-
97	B66_L11_P	D4	98	B66_L20_P	C6
99	B66_L11_N	C4	100	B66_L20_N	B6
101	GND	-	102	GND	-
103	B66_L12_P	C3	104	B66_L7_P	C1
105	B66_L12_N	C2	106	B66_L7_N	B1
107	GND	-	108	GND	-
109	B66_L13_N	D6	110	B66_L10_P	B4
111	B66_L13_P	D7	112	B66_L10_N	A4
113	GND	-	114	GND	-
115	B66_L8_N	A1	116	B66_L9_P	B3
117	B66_L8_P	A2	118	B66_L9_N	A3
119	GND	-	120	GND	-

Pin assignment of board to board connector J30

J30 Pin	Signal Name	Pin Number	J30 Pin	Signal Name	Pin Number
1	B66_L14_P	E5	2	FPGA_TDI	R18
3	B66_L14_N	D5	4	FPGA_TCK	R19

5	GND	-	6	GND	-
7	B66_L22_P	C8	8	FPGA_TDO	T21
9	B66_L22_N	B8	10	FPGA_TMS	N21
11	GND	-	12	GND	-
13	B66_L19_N	A5	14	B66_L21_N	A6
15	B66_L19_P	B5	16	B66_L21_P	A7
17	GND	-	18	GND	-
19	B66_L24_P	C9	20	B66_L17_P	F8
21	B66_L24_N	B9	22	B66_L17_N	E8
23	GND	-	24	GND	-
25	B66_L23_N	A8	26	B45_L9_P	C11
27	B66_L23_P	A9	28	B45_L9_N	B10
29	GND	-	30	GND	-
31	B45_L5_N	F10	32	B45_L10_P	B11
33	B45_L5_P	G11	34	B45_L10_N	A10
35	GND	-	36	GND	-
37	B66_L18_N	D9	38	B45_L12_P	D12
39	B66_L18_P	E9	40	B45_L12_N	C12
41	GND	-	42	GND	-
43	B45_L4_N	H12	44	B45_L11_P	A12
45	B45_L4_P	J12	46	B45_L11_N	A11
47	GND	-	48	GND	-
49	B46_L11_P	K14	50	B45_L6_N	F11
51	B46_L11_N	J14	52	B45_L6_P	F12
53	GND	-	54	GND	-
55	B46_L10_N	H13	56	B46_L6_N	E13
57	B46_L10_P	H14	58	B46_L6_P	E14
59	GND	-	60	GND	-
61	B46_L7_N	F13	62	B46_L3_N	A13
63	B46_L7_P	G13	64	B46_L3_P	B13
65	GND	-	66	GND	-
67	B46_L9_N	G14	68	B46_L2_N	A14
69	B46_L9_P	G15	70	B46_L2_P	B14
71	GND	-	72	GND	-
73	B46_L5_N	D14	74	B46_L4_N	C13
79	B46_L5_P	D15	76	B46_L4_P	C14

77	GND	-	78	GND	-
79	B46_L1_P	B15	80	B46_L12_P	L14
81	B46_L1_N	A15	82	B46_L12_N	L13
83	GND	-	84	GND	-
85	505_CLK2_P	C21	86	505_CLK1_P	E21
87	505_CLK2_N	C22	88	505_CLK1_N	E22
89	GND	-	90	GND	-
91	505_CLK0_P	F23	92	505_CLK3_P	A21
93	505_CLK0_N	F24	94	505_CLK3_N	A22
95	GND	-	96	GND	-
97	505_TX0_P	E25	98	505_TX3_P	B23
99	505_TX0_N	E26	100	505_TX3_N	B24
101	GND	-	102	GND	-
103	505_RX0_P	F27	104	505_RX3_P	A25
105	505_RX0_N	F28	106	505_RX3_N	A26
107	GND	-	108	GND	-
109	505_TX1_P	D23	110	505_TX2_P	C25
111	505_TX1_N	D24	112	505_TX2_N	C26
113	GND	-	114	GND	-
115	505_RX1_P	D27	116	505_RX2_P	B27
117	505_RX1_N	D28	118	505_RX2_N	B28
119	GND	-	120	GND	-

Pin assignment of board to board connector J31

J31 Pin	Signal Name	Pin Number	J31 Pin	Signal Name	Pin Number
1	B44_L10_P	Y14	2	B44_L7_P	AA13
3	B44_L10_N	Y13	4	B44_L7_N	AB13
5	GND	-	6	GND	-
7	B44_L6_P	AC14	8	B43_L6_P	AC12
9	B44_L6_N	AC13	10	B43_L6_N	AD12
11	GND	-	12	GND	-
13	B44_L5_P	AD15	14	B43_L7_P	AD11
15	B44_L5_N	AD14	16	B43_L7_N	AD10
17	GND	-	18	GND	-
19	B44_L1_P	AE15	20	B43_L8_N	AC11

21	B44_L1_N	AE14	22	B43_L8_P	AB11
23	GND	-	24	GND	-
25	B44_L12_P	Y12	26	B44_L2_P	AG14
27	B44_L12_N	AA12	28	B44_L2_N	AH14
29	GND	-	30	GND	-
31	B44_L3_P	AG13	32	-	-
33	B44_L3_N	AH13	34	-	-
35	GND	-	36	GND	-
37	B43_L12_N	AB9	38	B43_L9_P	AA11
39	B43_L12_P	AB10	40	B43_L9_N	AA10
41	GND	-	42	GND	-
43	B43_L10_N	Y10	44	B43_L3_P	AH12
45	B43_L10_P	W10	46	B43_L3_N	AH11
47	GND	-	48	GND	-
49	B44_L11_N	W11	50	B43_L1_N	AH10
51	B44_L11_P	W12	52	B43_L1_P	AG10
53	GND	-	54	GND	-
55	B44_L9_N	W13	56	B44_L4_P	AE13
57	B44_L9_P	W14	58	B44_L4_N	AF13
59	GND	-	60	GND	-
61	B44_L8_P	AB15	62	B43_L5_P	AE12
63	B44_L8_N	AB14	64	B43_L5_N	AF12
65	GND	-	66	GND	-
67	B43_L2_N	AG11	68	B43_L4_P	AE10
69	B43_L2_P	AF11	70	B43_L4_N	AF10
71	GND	-	72	GND	-
73	VBAT_IN	-	74	B43_L11_P	Y9
75	MR	-	76	B43_L11_N	AA8
77	GND	-	78	GND	-
79	-	-	80	PS_POR_B	P16
81	-	-	82	-	-
83	GND	-	84	GND	-
86	-	-	86	-	-
87	-	-	88	-	-
89	GND	-	90	GND	-
91	224_CLK0_P	Y6	92	224_CLK1_P	V6

93	224_CLK0_N	Y5	94	224_CLK1_N	V5
95	GND	-	96	GND	-
97	224_TX3_N	N3	98	224_RX3_N	P1
99	224_TX3_P	N4	100	224_RX3_P	P2
101	GND	-	102	GND	
103	224_TX2_N	R3	104	224_RX2_N	T1
105	224_TX2_P	R4	106	224_RX2_P	T2
107	GND		108	GND	
109	224_TX1_N	U3	110	224_RX1_N	V1
111	224_TX1_P	U4	112	224_RX1_P	V2
113	GND	-	114	GND	-
115	224_TX0_N	W3	116	224_RX0_N	Y1
117	224_TX0_P	W4	118	224_RX0_P	Y2
119	GND	-	120	GND	-

Pin assignment of board to board connector J32

J32 Pin	Signal Name	Pin Number	J32 Pin	Signal Name	Pin Number
1	PS_MIO35	H17	2	PS_MIO30	F16
3	PS_MIO29	G16	4	PS_MIO31	H16
5	GND	-	-	GND	-
7	-	-	8	PS_MIO58	F18
9	-	-	10	PS_MIO53	D16
11	GND	-	12	GND	-
13	PS_MODE0	P19	14	PS_MIO52	G18
15	PS_MODE1	P20	16	PS_MIO55	B16
17	GND	-	18	GND	-
19	PS_MODE2	R20	20	PS_MIO56	C16
21	PS_MODE3	T20	22	PS_MIO57	A16
23	GND	-	24	GND	-
25	PS_MIO36	K17	26	PS_MIO54	F17
27	PS_MIO37	J17	28	PS_MIO27	J15
29	GND	-	30	GND	-
31	-	-	32	PS_MIO28	K15
33	PS_MIO77	F20	34	PS_MIO59	E17
35	GND	-	36	GND	-

37	PS_MIO76	B20	38	PS_MIO60	C17
39	-	-	40	PS_MIO61	D17
41	GND	-	42	GND	-
43	PS_MIO39	H19	44	PS_MIO62	A17
45	PS_MIO38	H18	46	PS_MIO63	E18
47	GND	-	48	GND	-
49	-	-	50	PS_MIO65	A18
51	PS_MIO40	K18	52	PS_MIO66	G19
53	GND	-	54	GND	-
55	PS_MIO44	J20	56	PS_MIO67	B18
57	PS_MIO45	K20	58	PS_MIO68	C18
59	GND	-	60	GND	-
61	PS_MIO47	H21	62	PS_MIO64	E19
63	PS_MIO48	J21	64	PS_MIO69	D19
65	GND	-	66	GND	-
67	PS_MIO41	J19	68	PS_MIO74	D20
69	PS_MIO32	J16	70	PS_MIO73	G21
71	GND	-	72	GND	-
73	PS_MIO46	L20	74	PS_MIO72	G20
75	PS_MIO50	M19	76	PS_MIO71	B19
77	GND	-	78	GND	-
79	PS_MIO49	M18	80	PS_MIO75	A19
81	PS_MIO34	L17	82	PS_MIO70	C19
83	GND	-	84	GND	-
85	PS_MIO26	L15	86	PS_MIO43	K19
87	PS_MIO24	AB19	88	PS_MIO51	L21
89	GND	-	90	GND	-
91	PS_MIO25	AB21	92	PS_MIO42	L18
93	-	-	94	PS_MIO33	L16
95	GND	-	96	GND	-
97	-	-	98	-	-
99	VCCO_65	-	100	VCCO_66	-
101	VCCO_65	-	102	VCCO_66	-
103	VCCO_65	-	104	VCCO_66	-
105	GND	-	106	GND	-
107	+12V	-	108	+12V	-

109	+12V	-	110	+12V	-
111	+12V	-	112	+12V	-
113	+12V	-	114	+12V	-
115	+12V	-	116	+12V	-
117	+12V	-	118	+12V	-
119	+12V	-	120	+12V	-

Part 3: Carrier Board

Part 3.1: Carrier Board Introduction

Through the previous function introduction, you can understand the function of the carrier board part

- 1-Channel M.2 interface
- 1-Channel DP output interface
- 4 USB 3.0 Interfaces
- 2-Channel 10/100M/1000M Ethernet RJ-45 interface
- 2-Channel USB Uart Interfaces
- 1-Channel Micro SD card slot
- 1-Channel MIPI camera interface
- 1-Channel HDMI video output interface
- 1-Channel HDMI video input interface
- 1-Channel FMC interface
- 2-Channel CAN communication interfaces
- 2-Channel 485 communication interfaces
- JTAG debugging interface
- 1-Channel temperature sensor
- 1-Channel EEPROM
- 1-Channel RTC real-time clock
- 3 LED lights
- 3 Keys

Part 3.2: M.2 Interface

The AXU5EVB-P development board is equipped with a PCIE x1 standard M.2 interface for connecting M.2 SSD solid state drives, with a communication speed of up to 6Gbps. The M.2 interface uses the M key slot, which only supports PCI-E, not SATA. When users choose SSD solid state drives, they

need to choose PCIE type SSD solid state drives.

The PCIE signal is directly connected to the BANK505 PS MGT transceiver of ZU5EV, and the TX signal and RX signal of one channel are connected to the LANE1 of MGT in a differential signal mode. The PCIE clock is provided by the Si5332 chip, the frequency is 100Mhz, and the schematic diagram of the M.2 circuit design is shown in Figure 3-2-1:

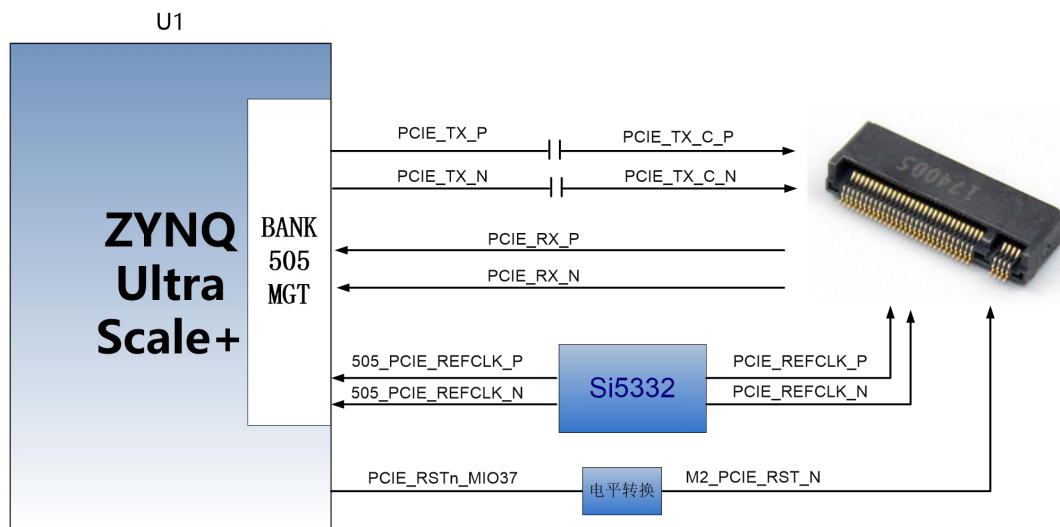

Figure 3-2-1: M.2 Interface Schematic

The pin assignment of M.2 interface ZYNQ is as follows:

Signal Name	Pin Name	Pin Number	Description
PCIE_TX_P	505_TX0_P	E25	PCIE Data Transmit Positive
PCIE_TX_N	505_TX0_N	E26	PCIE Data Transmit Negative
PCIE_RX_P	505_RX0_P	F27	PCIE Data Receive Positive
PCIE_RX_N	505_RX0_N	F28	PCIE Data Receive Negative
505_PCIE_REFCLK_P	505_CLK0_P	F23	PCIE Reference Clock Positive
505_PCIE_REFCLK_N	505_CLK0_N	F24	PCIE Reference Clock Negative
PCIE_RSTn_MIO37	PS_MIO37_501	J17	PCIE Reset Signal

Part 3.3: DP Interface

The AXU5EVB-P development board has a standard Display Port output display interface for video image display. The interface supports VESA

DisplayPort V1.2a output standard, up to 4K x 2K@30Fps output, supports Y-only, YCbCr444, YCbCr422, YCbCr420 and RGB video formats, each color supports 6, 8, 10, or 12 bits.

The DisplayPort data transmission channel is directly driven and output by the BANK505 PS MGT of ZU4EV, and the LANE2 and LANE3 TX signals of MGT are connected to the DP connector in a differential signal mode. The DisplayPort auxiliary channel is connected to the MIO pin of the PS. The schematic diagram of the DP output interface design is shown in Figure 3-3-1:

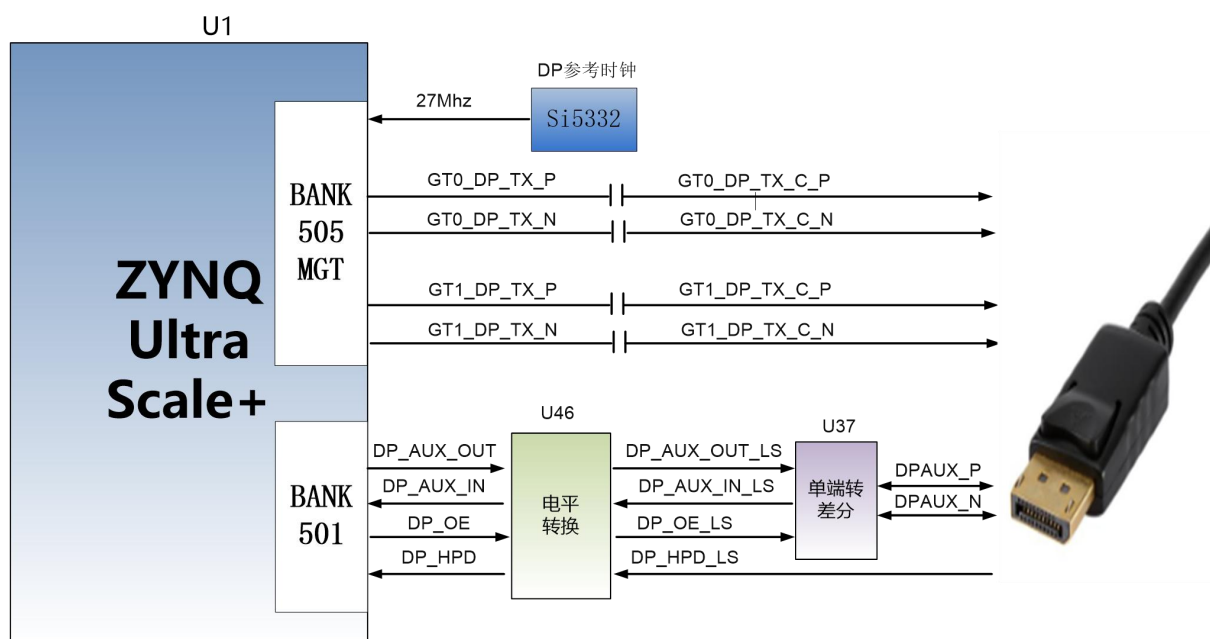

Figure 3-3-1: DP interface design Schematic

The DisplayPort interface ZYNQ pin assignment is as follows:

Signal Name	ZYNQ Pin Number	ZYNQ Pin Number	Description
GT0_DP_TX_P	505_TX3_P	B23	Low bits of DP Data Transmit Positive
GT0_DP_TX_N	505_TX3_N	B24	Low bits of DP Data Transmit Negative
GT1_DP_TX_P	505_TX2_P	C25	High bits of DP Data Transmit Positive
GT1_DP_TX_N	505_TX2_N	C26	High bits of DP Data Transmit Negative

505_CLK1_P	505_CLK2_P	C21	DP Reference Clock Positive
505_CLK1_N	505_CLK2_N	C22	DP Reference Clock Negative
DP_AUX_OUT	PS_MIO27	J15	DP Auxiliary Data Output
DP_AUX_IN	PS_MIO30	F16	DP Auxiliary Data Input
DP_OE	PS_MIO29	G16	DP Auxiliary Data Output Enable
DP_HPD	PS_MIO28	K15	DP Insertion Signal Detection

Part 3.4: USB3.0 Interface

There are 4 USB3.0 ports on the AXU5EVB-P carrier board, supporting the HOST working mode, and the data transmission speed is up to 5.0Gb/s. USB3.0 is connected through the PIPE3 interface, and USB2.0 is connected to the external USB3320C chip through the ULPI interface to realize high-speed USB3.0 and USB2.0 data communication.

The USB interface is a flat USB interface (USB Type A), which is convenient for users to connect different USB Slave peripherals (such as USB mouse, keyboard or U disk) at the same time. The schematic diagram of USB3.0 connection is shown as 3-4-1:

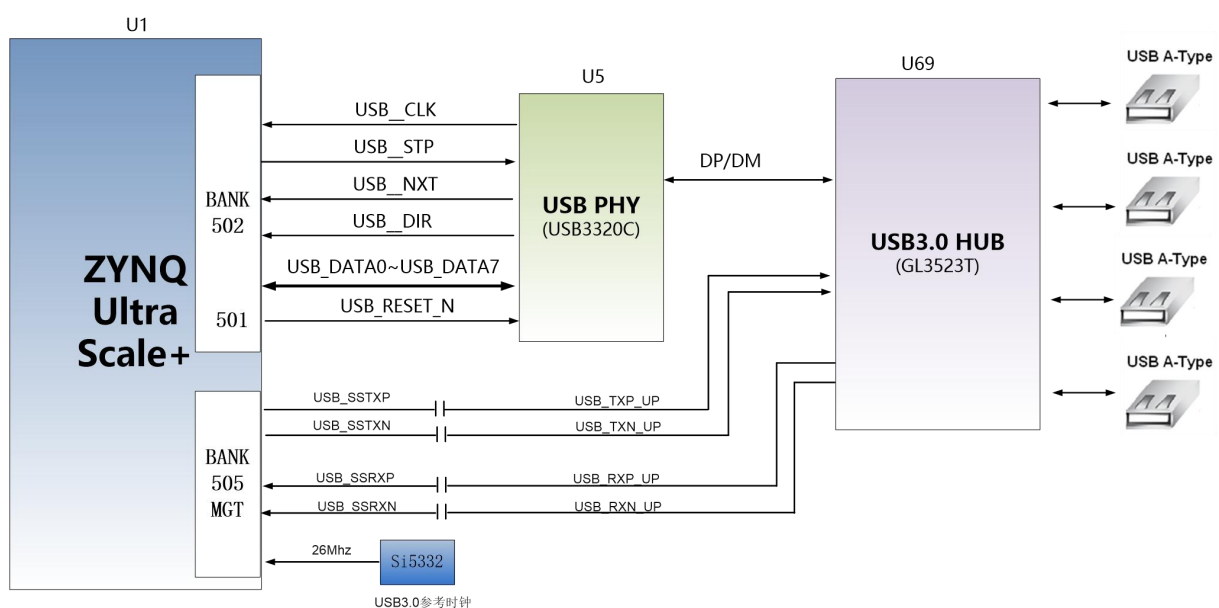

Figure 3-4-1: USB3.0 Interface Schematic

USB Interface Pin Assignment:

Signal Name	Pin Name	Pin Number	Description
USB_SSTXP	505_TX1_P	D23	USB3.0 Data Transmit Positive
USB_SSTXN	505_TX1_N	D24	USB3.0 Data Transmit Negative
USB_SSRXP	505_RX1_P	D27	USB3.0 Data Receive Positive
USB_SSRXN	505_RX1_N	D28	USB3.0 Data Receive Negative
USB_DATA0	PS_MIO56	C16	USB2.0 Data Bit0
USB_DATA1	PS_MIO57	A16	USB2.0 Data Bit1
USB_DATA2	PS_MIO54	F17	USB2.0 Data Bit2
USB_DATA3	PS_MIO59	E17	USB2.0 Data Bit3
USB_DATA4	PS_MIO60	C17	USB2.0 Data Bit4
USB_DATA5	PS_MIO61	D17	USB2.0 Data Bit5
USB_DATA6	PS_MIO62	A17	USB2.0 Data Bit6
USB_DATA7	PS_MIO63	E18	USB2.0 Data Bit7
USB_STP	PS_MIO58	F18	USB2.0 Stop Signal
USB_DIR	PS_MIO53	D16	USB2.0 Data Direction Signal
USB_CLK	PS_MIO52	G18	USB2.0 Clock Signal
USB_NXT	PS_MIO55	B16	USB2.0 Next Data Signal
USB_RESET_N	PS_MIO31	H16	USB2.0 Reset Signal

Part 3.5: Gigabit Ethernet Interface

There are 2 Gigabit Ethernet ports on the AXU5EVB-P carrier board, one is connected to the PS end, and the other is connected to the PL end. The Ethernet chip adopts Jinglue Semiconductor's industrial grade Ethernet GPHY chip (JL2121-N040I) to provide users with network communication services. The JL2121 chip supports 10/100/1000 Mbps network transmission rate, and communicates with the MAC layer of the ZU4EV system through the RGMII interface. JL2121 supports MDI/MDX adaptation, various speed adaptation, Master/Slave adaptation, and MDIO bus for PHY register management.

When the JL2121 is powered on, it will detect the level status of some specific IOs to determine its own operating mode. Table 3-5-1 describes the default settings after the GPHY chip is powered on.

Configuration Pin	Instructions	Configuration value
RXD3_ADR0 RXC_ADR1 RXCTL_ADR2	MDIO/MDC Mode PHY Address	PHY Address 001
RXD1_TXDLY	TX clock 2ns delay	Delay
RXD0_RXDLY	RX clock 2ns delay	Delay

Table 3-5-1: PHY chip default configuration value

When the network is connected to Gigabit Ethernet, the data transmission of ZYNQ and PHY chip JL2121 is communicated through the RGMII bus, the transmission clock is 125Mhz, and the data is sampled on the rising edge and falling samples of the clock.

When the network is connected to 100Mbps Ethernet, the data transmission of ZYNQ and PHY chip JL2121 is communicated through RMII bus, and the transmission clock is 25Mhz. Data is sampled on the rising edge and falling samples of the clock.

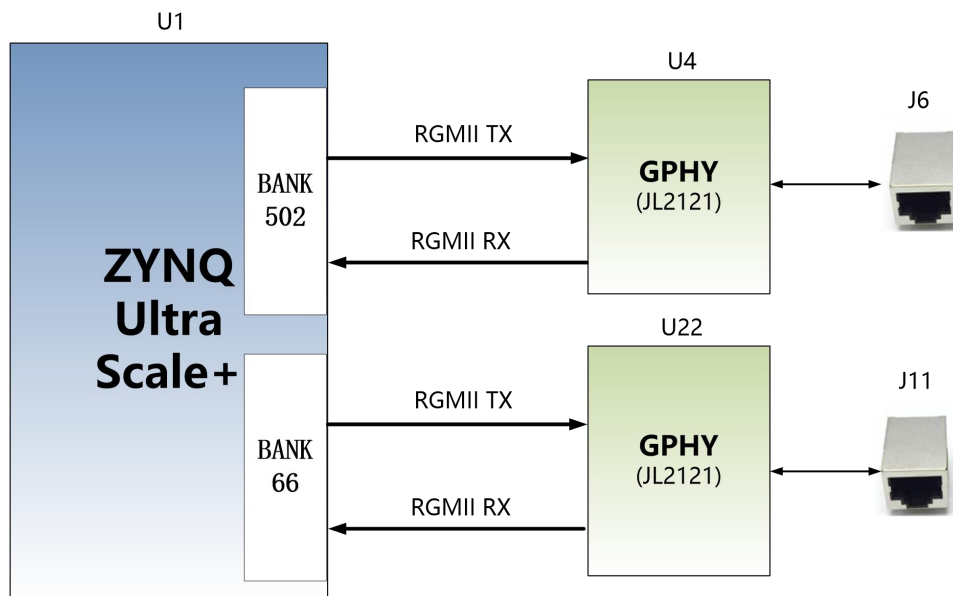

Figure 3-6-1: ZYNQ PS system and GPHY connection diagram

The Gigabit Ethernet pin assignments are as follows:

Signal Name	Pin Name	Pin Number	Description
-------------	----------	------------	-------------

PHY1_TXCK	PS_MIO64	E19	Ethernet 1 RGMII Transmit Clock
PHY1_TXD0	PS_MIO65	A18	Ethernet 1 Transmit data bit0
PHY1_TXD1	PS_MIO66	G19	Ethernet 1 Transmit data bit1
PHY1_TXD2	PS_MIO67	B18	Ethernet 1 Transmit data bit2
PHY1_TXD3	PS_MIO68	C18	Ethernet 1 Transmit data bit3
PHY1_TXCTL	PS_MIO69	D19	Ethernet 1 Transmit Enable Signal
PHY1_RXCK	PS_MIO70	C19	Ethernet 1 RGMII Receive Clock
PHY1_RXD0	PS_MIO71	B19	Ethernet 1 Receive Data Bit0
PHY1_RXD1	PS_MIO72	G20	Ethernet 1 Receive Data Bit1
PHY1_RXD2	PS_MIO73	G21	Ethernet 1 Receive Data Bit2
PHY1_RXD3	PS_MIO74	D20	Ethernet 1 Receive Data Bit3
PHY1_RXCTL	PS_MIO75	A19	Ethernet 1 Receive Enable Signal
PHY1_MDC	PS_MIO76	B20	Ethernet 1 MDIO Clock Management
PHY1_MDIO	PS_MIO77	F20	Ethernet 1 MDIO Management Data
PHY2_TXCK	B66_L17_N	E8	Ethernet 2 RGMII Transmit Clock
PHY2_TXD0	B66_L18_P	E9	Ethernet 2 Transmit data bit0
PHY2_TXD1	B66_L18_N	D9	Ethernet 2 Transmit data bit1
PHY2_TXD2	B66_L23_P	A9	Ethernet 2 Transmit data bit2
PHY2_TXD3	B66_L23_N	A8	Ethernet 2 Transmit data bit3
PHY2_TXCTL	B66_L24_N	B9	Ethernet 2 Transmit Enable Signal
PHY2_RXCK	B66_L14_P	E5	Ethernet 2 RGMII Receive Clock
PHY2_RXD0	B66_L19_N	A5	Ethernet 2 Receive Data Bit0
PHY2_RXD1	B66_L19_P	B5	Ethernet 2 Receive Data Bit1
PHY2_RXD2	B66_L17_P	F8	Ethernet 2 Receive Data Bit2
PHY2_RXD3	B66_L24_P	C9	Ethernet 2 Receive Data Bit3
PHY2_RXCTL	B66_L22_N	B8	Ethernet 2 Receive Enable Signal
PHY2_MDC	B66_L21_N	A6	Ethernet 2 MDIO Clock Management
PHY2_MDIO	B66_L22_P	C8	Ethernet 2 MDIO Management Data
PHY2_RESET	B66_L14_N	D5	Ethernet 2 Reset Signal

Part 3.6: USB to Serial Port

The AXU5EV-P carrier board is equipped with two Uart to USB ports, one is connected to the PS end, and one is connected to the PL end.

The conversion chip uses Silicon Labs CP2102GM's USB-UAR chip, and

the USB interface is a MINI USB interface. You can use a USB cable to connect it to the PC's USB port for serial data communication. The schematic diagram of the USB Uart circuit design is shown in the figure below:

The schematic diagram of the USB Uart circuit design is shown in Figure 3-6-1:

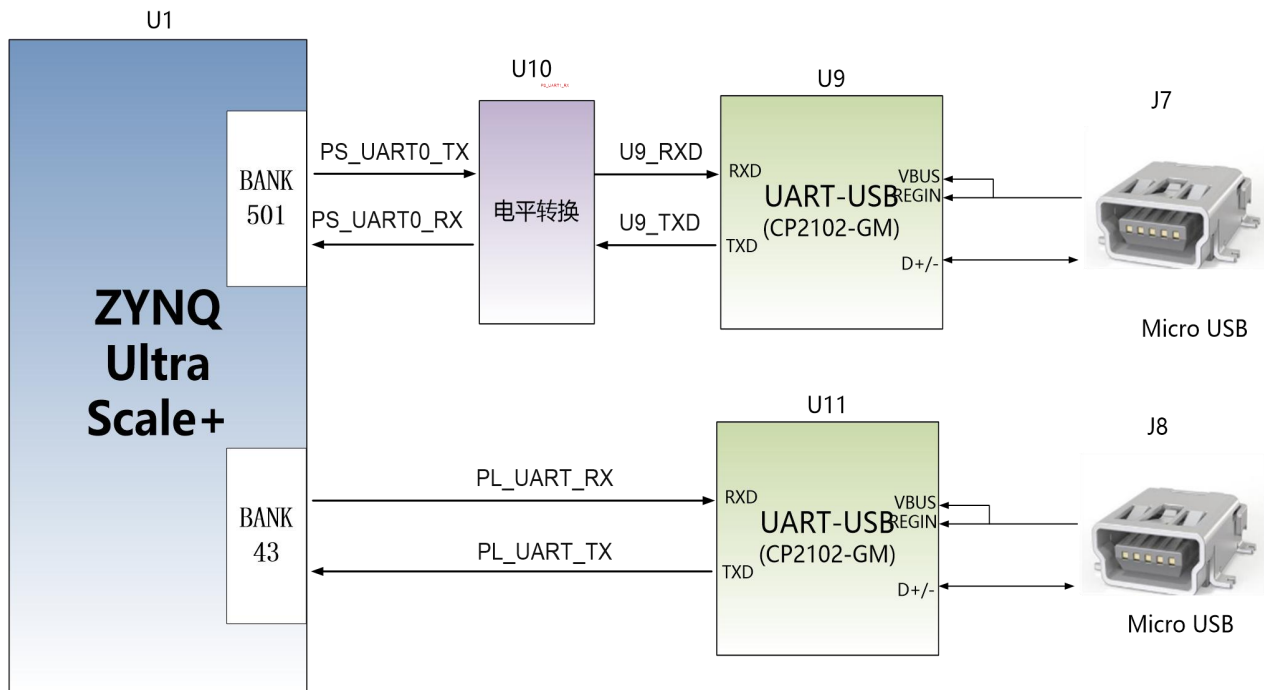

Figure 3-6-1: USB to serial port schematic

USB to serial port ZYNQ pin assignment:

Signal name	Pin Name	Pin Number	Description
PS_UART0_TX	PS_MIO43	K19	PS Uart Data Output
PS_UART0_RX	PS_MIO42	L18	PS Uart Data Input
PL_UART_TX	B43_L0_P	AH11	PL Uart Data Output
PL_UART_RX	B43_L9_N	AH10	PL Uart Data Input

Part 3.7: SD Card Slot Interface

The AXU5EV-P FPGA Development Board contains a Micro SD card interface to provide user access to the SD card memory, the BOOT program for the ZU4EV chip, the Linux operating system kernel, the file system and other user data files.

The SDIO signal is connected to the IO signal of the PS BANK501 of ZU4EV. Since the VCCMIO of the BANK is set to 1.8V, but the data level of the SD card is 3.3V, connected through the TXS02612 level shifter. The schematic of the Zynq7000 PS and SD card connector is shown in Figure 3-7-1:

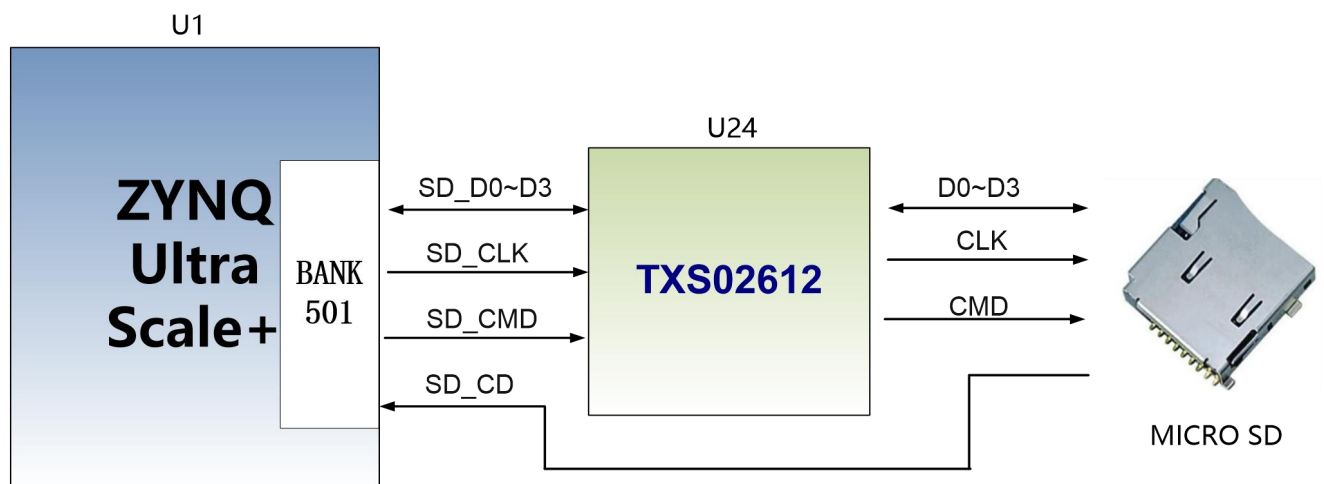

Figure 3-7-1: SD Card Connection Diagram

SD card slot pin assignment:

Signal Name	Pin Name	Pin Number	Description
SD_CLK	PS_MIO51	I21	SD Clock Signal
SD_CMD	PS_MIO50	M19	SD Command Signal
SD_D0	PS_MIO46	L20	SD Data0
SD_D1	PS_MIO47	H21	SD Data1
SD_D2	PS_MIO48	J21	SD Data2
SD_D3	PS_MIO49	M18	SD Data3
SD_CD	PS_MIO45	K20	SD card insertion signal

Part 3.8: HDMI Output Interface

The HDMI output interface uses the ADV7511 HDMI (DVI) encoding chip from ANALOG DEVICE, which supports up to 1080P@60Hz output and 3D output.

The video digital interface, audio digital interface and I2C configuration interface of ADV7511 are connected to the BANK45, 46 IO of the ZU4EV PL part. The ZYNQ UltraScale+ system initializes and controls the ADV7511 through the I2C pin. The hardware connection diagram of ADV7511 chip and ZYNQ UltraScale+ is shown in Figure 3-8-1:

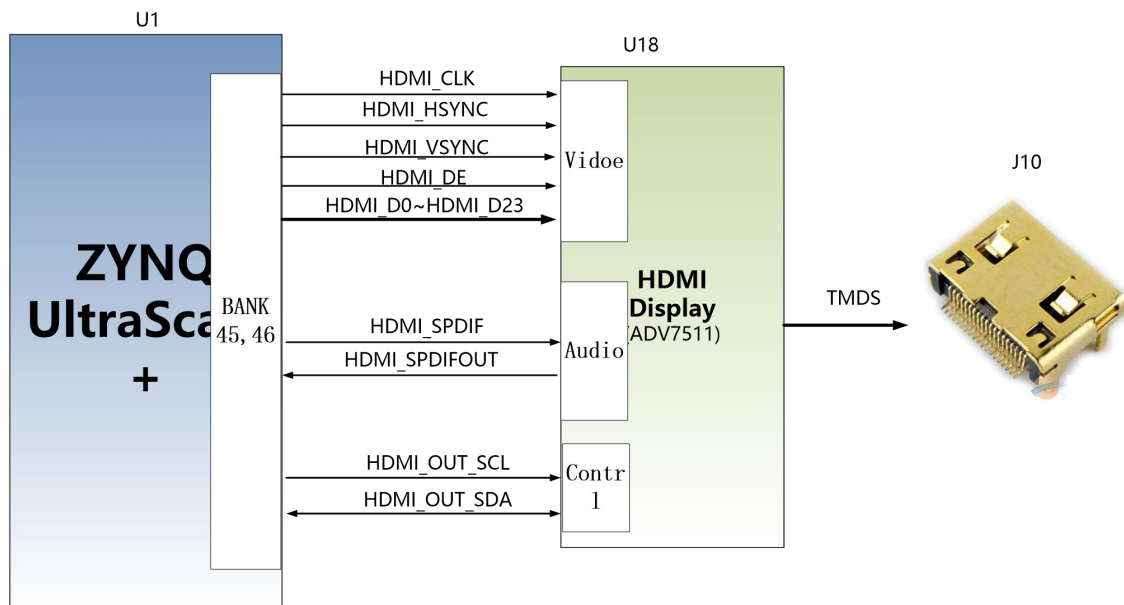

Figure 3-8-1: HDMI Output Interface Schematic

ZYNQ pin assignment:

Signal Name	ZYNQ Pin Name	ZYNQ Pin Number	Description
HDMI_CLK	B35_L4_N	H14	HDMI Video Signal Clock
HDMI_HSYNC	B35_L2_P	J13	HDMI Video Signal Line Synchronization
HDMI_VSYNC	B35_L2_N	H13	HDMI Video Signal Column Synchronization
HDMI_DE	B35_L9_P	G12	HDMI Video Signal Enable
HDMI_D0	B35_L9_N	F12	HDMI Video Signal Data0
HDMI_D1	B35_L22_N	B11	HDMI Video Signal Data1

HDMI_D2	B35_L22_P	C11	HDMI Video Signal Data2
HDMI_D3	B35_L20_N	B12	HDMI Video Signal Data3
HDMI_D4	B35_L20_P	C12	HDMI Video Signal Data4
HDMI_D5	B35_L19_N	C13	HDMI Video Signal Data5
HDMI_D6	B35_L19_P	C14	HDMI Video Signal Data6
HDMI_D7	B35_L24_N	A12	HDMI Video Signal Data7
HDMI_D8	B35_L24_P	A13	HDMI Video Signal Data8
HDMI_D9	B35_L4_P	J14	HDMI Video Signal Data9
HDMI_D10	B35_L1_N	L14	HDMI Video Signal Data10
HDMI_D11	B35_L1_P	L15	HDMI Video Signal Data11
HDMI_D12	B35_L16_N	C16	HDMI Video Signal Data12
HDMI_D13	B35_L16_P	D16	HDMI Video Signal Data13
HDMI_D14	B35_L18_N	A17	HDMI Video Signal Data14
HDMI_D15	B35_L18_P	B17	HDMI Video Signal Data15
HDMI_D16	B35_L15_N	E17	HDMI Video Signal Data16
HDMI_D17	B35_L15_P	F17	HDMI Video Signal Data17
HDMI_D18	B35_L7_N	G16	HDMI Video Signal Data18
HDMI_D19	B35_L7_P	G17	HDMI Video Signal Data19
HDMI_D20	B35_L6_N	H16	HDMI Video Signal Data20
HDMI_D21	B35_L6_P	J16	HDMI Video Signal Data21
HDMI_D22	B35_L17_P	C17	HDMI Video Signal Data22
HDMI_D23	B35_L17_N	B16	HDMI Video Signal Data23
HDMI_SCL	B35_L13_N	E15	HDMI IIC Control Clock
HDMI_SDA	B35_L13_P	E16	HDMI IIC Control Data

Part 3.9: HDMI Input Interface

HDMI input interface, using ADV7611 decoder chip from ANALOG DEVICE, supports up to 1080P@60Hz input and supports data output in different formats. The IIC configuration interface of ADV7611 is also connected to the IO of ZU4EV PL. ZYNQ initializes and controls ADV7611 through I2C bus programming. The hardware schematic of the HDMI input interface is shown in Figure 3-9-1.

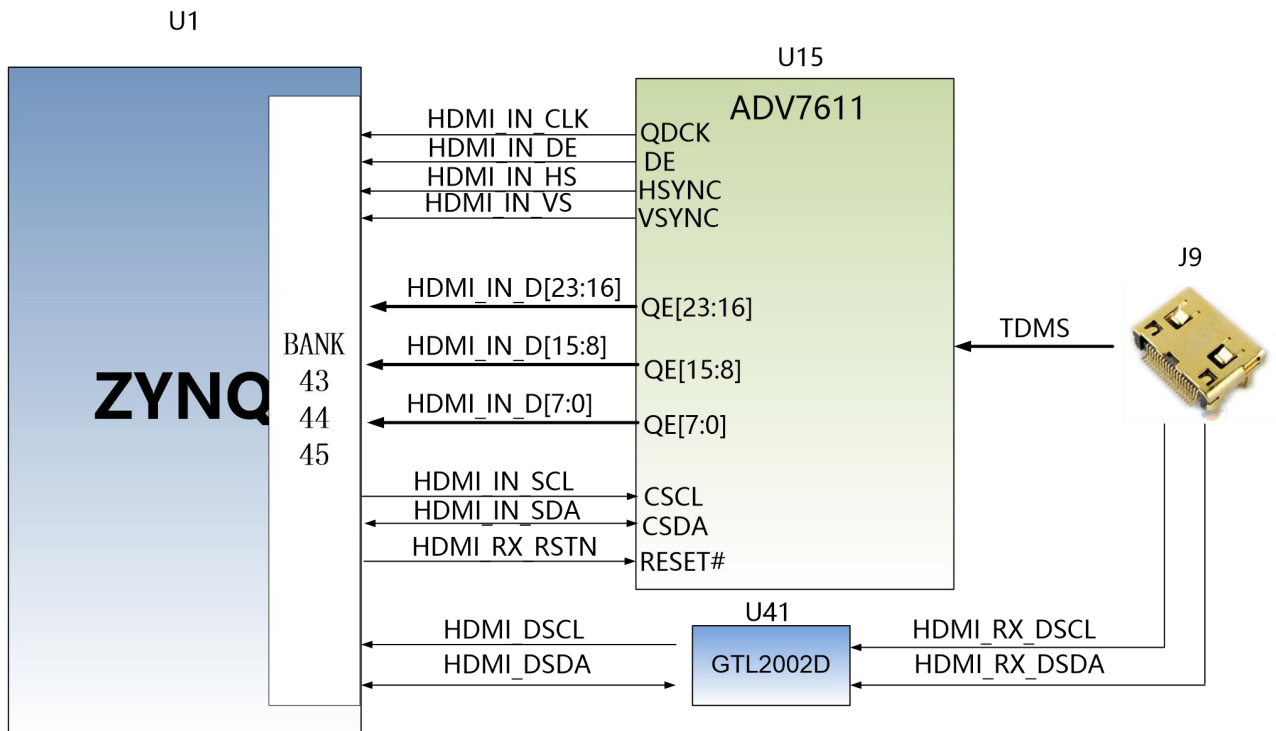

Figure 3-9-1: HDMI Input Interface Schematic

ZYNQ pin assignment:

Signal Name	ZYNQ Pin Name	ZYNQ Pin Number	Description
9013_nRESET	B11_L19_P	AB21	HDMI Reset Signal
HDMI_RX_RSTN	B43_L7_N	AD10	HDMI Input Video Signal Clock
HDMI_IN_CLK	B43_L8_P	AB11	HDMI Input Video Signal Line Synchronization
HDMI_IN_HS	B44_L12_N	AA12	HDMI Input Video Signal Column Synchronization
HDMI_IN_VS	B44_L12_P	Y12	HDMI Input Video Signal Enable
HDMI_IN_DE	B44_L7_P	AA13	HDMI Input Video Signal Data0
HDMI_IN_D0	B44_L10_P	Y14	HDMI Input Video Signal Data1
HDMI_IN_D1	B44_L10_N	Y13	HDMI Input Video Signal Data2
HDMI_IN_D2	B44_L7_N	AB13	HDMI Input Video Signal Data3
HDMI_IN_D3	B43_L6_P	AC12	HDMI Input Video Signal Data4
HDMI_IN_D4	B44_L6_P	AC14	HDMI Input Video Signal Data5
HDMI_IN_D5	B44_L6_N	AC13	HDMI Input Video Signal Data6
HDMI_IN_D6	B43_L6_N	AD12	HDMI Input Video Signal Data7
HDMI_IN_D7	B43_L7_P	AD11	HDMI Input Video Signal Data8
HDMI_IN_D8	B44_L5_P	AD15	HDMI Input Video Signal Data9

HDMI_IN_D9	B44_L5_N	AD14	HDMI Input Video Signal Data10
HDMI_IN_D10	B44_L3_P	AG13	HDMI Input Video Signal Data11
HDMI_IN_D11	B44_L3_N	AH13	HDMI Input Video Signal Data12
HDMI_IN_D12	B43_L12_N	AB9	HDMI Input Video Signal Data13
HDMI_IN_D13	B43_L12_P	AB10	HDMI Input Video Signal Data14
HDMI_IN_D14	B43_L10_N	Y10	HDMI Input Video Signal Data15
HDMI_IN_D15	B43_L10_P	W10	HDMI Input Video Signal Data16
HDMI_IN_D16	B44_L11_N	W11	HDMI Input Video Signal Data17
HDMI_IN_D17	B44_L11_P	W12	HDMI Input Video Signal Data18
HDMI_IN_D18	B44_L9_N	W13	HDMI Input Video Signal Data19
HDMI_IN_D19	B44_L9_P	W14	HDMI Input Video Signal Data20
HDMI_IN_D20	B44_L8_P	AB15	HDMI Input Video Signal Data21
HDMI_IN_D21	B44_L8_N	AB14	HDMI Input Video Signal Data22
HDMI_IN_D22	B43_L2_N	AG11	HDMI Input Video Signal Data23
HDMI_IN_SDA	B43_L5_P	AE12	ADV7611 IIC Control Clock
HDMI_IN_SCL	B43_L5_N	AF12	ADV7611 IIC Control Data
HDMI_DSCL	B45_L5_N	F10	EDID Read IIC Clock
HDMI_DSDA	B45_L5_P	G11	EDID Read IIC Data

Part 3.10: SFP Interface

The AXU5EVB-P FPGA carrier board has two optical interfaces. Users can purchase SFP optical modules (1.25G, 2.5G optical modules on the market) and insert them into these four optical interfaces for optical data communication. The two fiber interfaces are connected to the two RX/TX of the GNK transceiver of ZYNQ BANK224, and the data rate of each TX transmission and RX reception is up to 12.5Gb/s. The reference clock of the GTH transceiver is provided by the 125M differential clock of the core board.

The SFP Schematic detailed is shown in Figure 3-10-1:

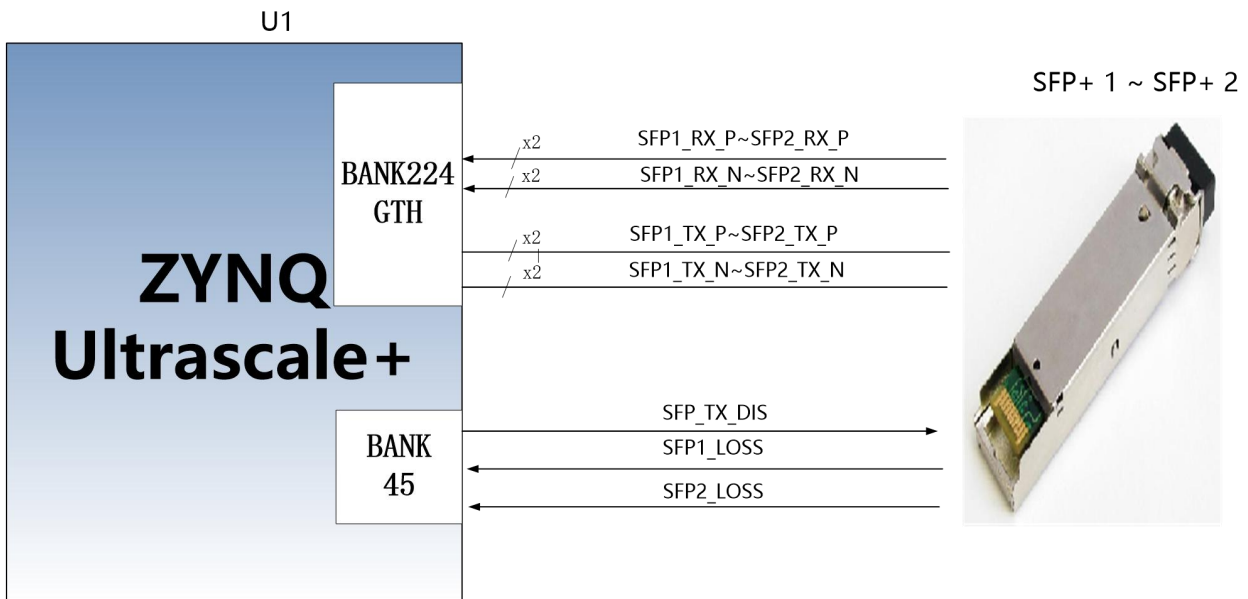

Figure 3-10-1: SFP Schematic

SFP ZYNQ pin assignment:

Signal Name	ZYNQ Pin Name	ZYNQ Pin Number	Description
SFP1_TX_N	224_TX0_N	W3	Optical Module 1 Data Transmit Negative
SFP1_TX_P	224_TX0_P	W4	Optical Module 1 Data Transmit Positive
SFP1_RX_N	224_RX0_N	Y1	Optical Module 1 Data Receive Negative
SFP1_RX_P	224_RX0_P	Y2	Optical Module 1 Data Receive Positive
SFP2_TX_N	224_TX1_N	U3	Optical Module 2 Data Transmit Negative
SFP2_TX_P	224_TX1_P	U4	Optical Module 2 Data Transmit Positive
SFP2_RX_N	224_RX1_N	V1	Optical Module 2 Data Receive Negative
SFP2_RX_P	224_RX1_P	V2	Optical Module 2 Data Receive Positive
SFP_TX_DIS	B45_L12_P	D12	Optical Module Light Emission Prohibited, High Level (Positive) Enable
SFP1_LOSS	B45_L9_N	B10	Optical Module 1 Receive LOSS Detect Signal
SFP2_LOSS	B45_L9_P	C11	Optical Module 2 Receive LOSS Detect Signal

Part 3.11: PCIe Slot

There is a PCIe x2 interface on the AXU5EVB-P carrier board, and two

pairs of transceivers are connected to the PCIeEx2, which can realize PCIe 3.0 (compatible 2.0) data communication.

The transceiver signal of the PCIe interface is directly connected to the GTH transceiver of ZYNQ BANK224, and the single-channel communication rate can be as high as 8G bit bandwidth.

The PCIe interface schematic is shown in Figure 3-11 below, where the TX signal is connected in AC coupling mode.

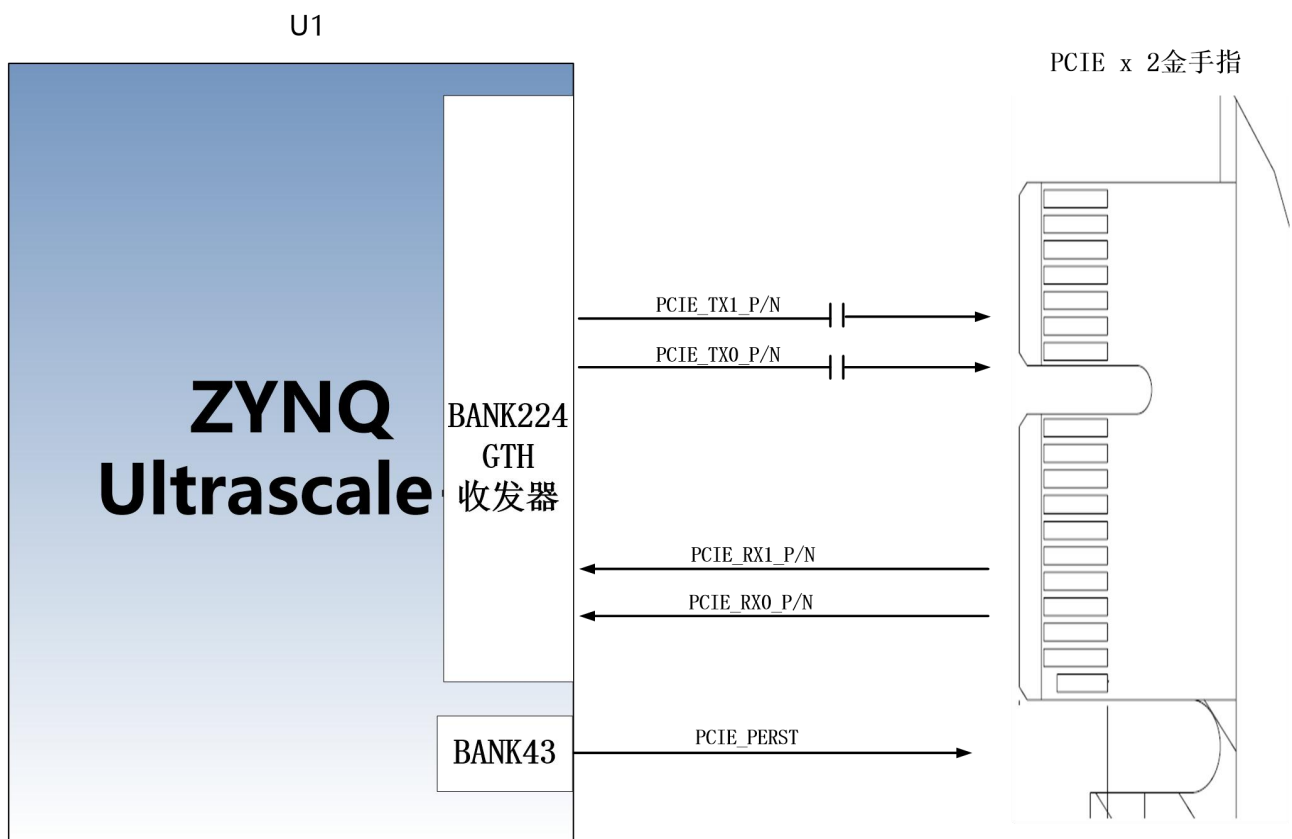

Figure 3-11: PCIe Interface Schematic

PCIe x2 Interface ZYNQ Pin Assignment

Signal Name	ZYNQ Pin Name	ZYNQ Pin Number	Description
PCIE_RX0_N	224_RX2_N	T1	PCIe Channel 0 Data Receive Negative
PCIE_RX0_P	224_RX2_P	T2	PCIe Channel 0 Data Receive Positive
PCIE_RX1_N	224_RX3_N	P1	PCIe Channel 1 Data Receive Negative
PCIE_RX1_P	224_RX3_P	P2	PCIe Channel 1 Data Receive Positive
PCIE_TX0_N	224_TX2_N	R3	PCIe Channel 0 Data Transmit Negative

PCIE_TX0_P	224_TX2_P	R4	PCIE Channel 0 Data Transmit Positive
PCIE_TX1_N	224_TX3_N	N3	PCIE Channel 1 Data Transmit Negative
PCIE_TX1_P	224_TX3_P	N4	PCIE Channel 1 Data Transmit Positive
PCIE_PERST	B43_L8_N	AC11	PCIE Board Reset Signal

Part 3.12: CAN Communication Interface

There are 2 CAN communication interfaces on the AXU5EVB-P carrier board, which are connected to the MIO interface of the BANK501 on the PS system side. The CAN transceiver chip selected TI's SN65HVD232C chip for user CAN communication services. The connection of the CAN transceiver chip on the PS side is show as Figure 3-12-1

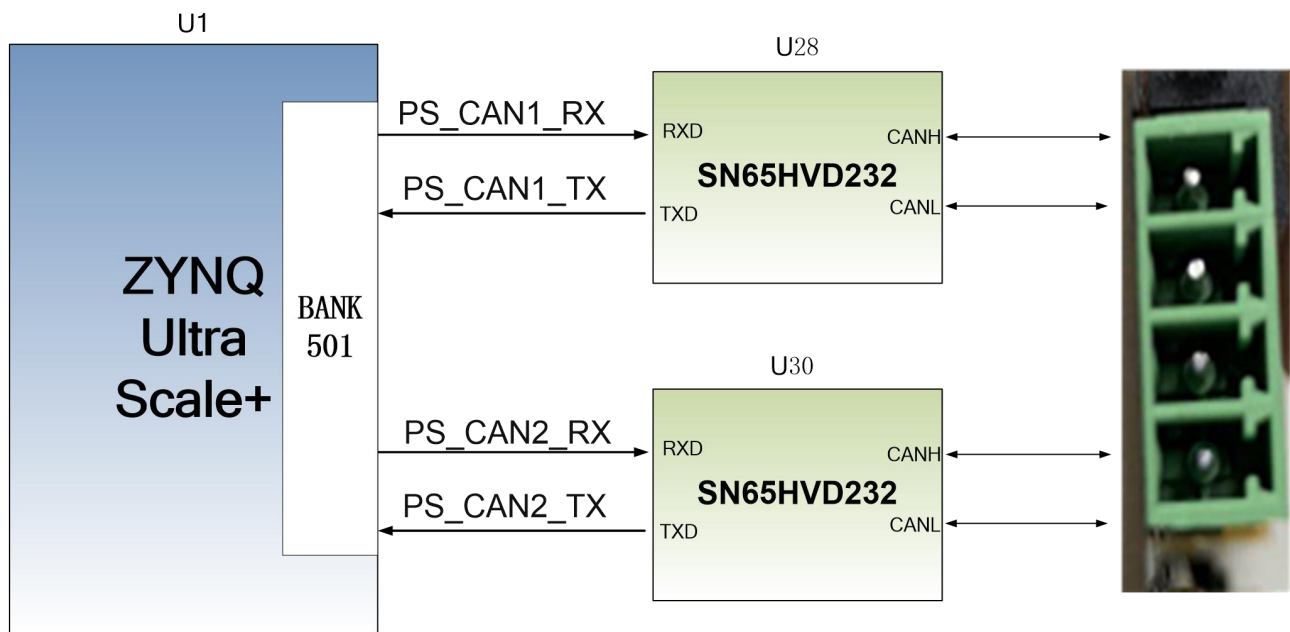

Figure 3-12-1: Connection diagram of CAN transceiver chip on PS side

The CAN communication pin assignments are as follows:

Signal Name	ZYNQ Pin Name	ZYNQ Pin Number	Description
PS_CAN1_TX	PS_MIO32	J16	CAN1 Transmitter
PS_CAN1_RX	PS_MIO33	L16	CAN1 Receiver
PS_CAN2_TX	PS_MIO39	H19	CAN2 Transmitter
PS_CAN2_RX	PS_MIO38	H18	CAN2 Receiver

Part 3.13: 485 Communication Interface

There are two 485 communication interfaces on the AXU5EVB-P carrier board. The 485 communication port 1 is connected to the IO interface of BANK43~45 on the PL system. The 485 transceiver chip selects the MAX3485 chip from MAXIM for the user's 485 communication service.

Figure 3-13-1 is the connection diagram of the 485 transceiver chip on the PL side

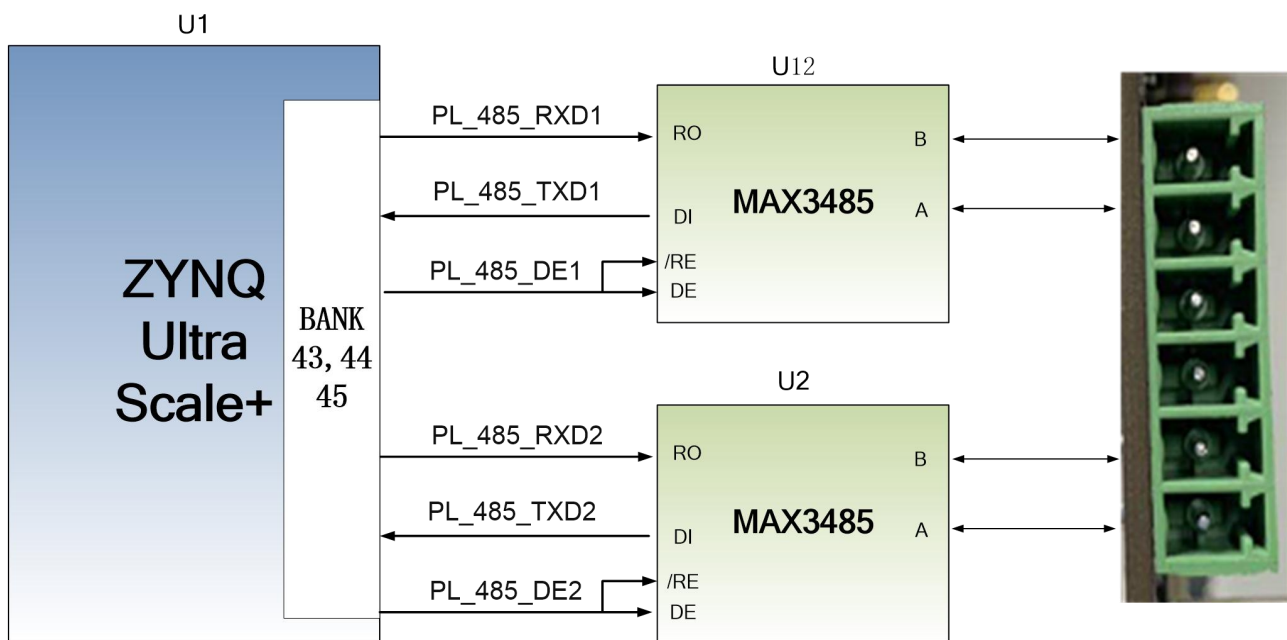

Figure 3-13-1: 485 Communication on the PL Side

The 485 communication pins are assigned as follows:

Signal Name	Pin Name	Pin Number	Description
PL_485_TXD1	B43_L1_P	AG10	The 1 st Channel 485 Transceiver
PL_485_RXD1	B43_L1_N	AH10	The 1 st Channel 485 Receiver
PL_485_DE1	B45_L10_N	A10	The 1 st Channel 485 Transmit Enable
PL_485_TXD2	B43_L3_N	AH11	The 2 nd Channel 485 Transceiver
PL_485_RXD2	B43_L3_P	AH12	The 2 nd Channel 485 Receiver
PL_485_DE2	B45_L10_P	B11	The 2 nd Channel 485 Transmit Enable

Part 3.14: MIPI Camera Interface

The AXU5EVB-P carrier board includes a MIPI camera interface, which

can be used to connect with the ALINX Brand MIPI OV5640 camera module AN5641. MIPI interface 15PIN FPC connector, 2 LANE data and 1 pair of clock, connected to the differential IO pin of BANK65, the level standard is 1.2V (**The jumper of J43 needs to be connected to PIN2 and PIN3 pins**); other control signals are connected to the IO of BANK43, level standard It is 3.3V.

The circuit schematic of the MIPI interface part is shown in Figure 3-14-1 below:

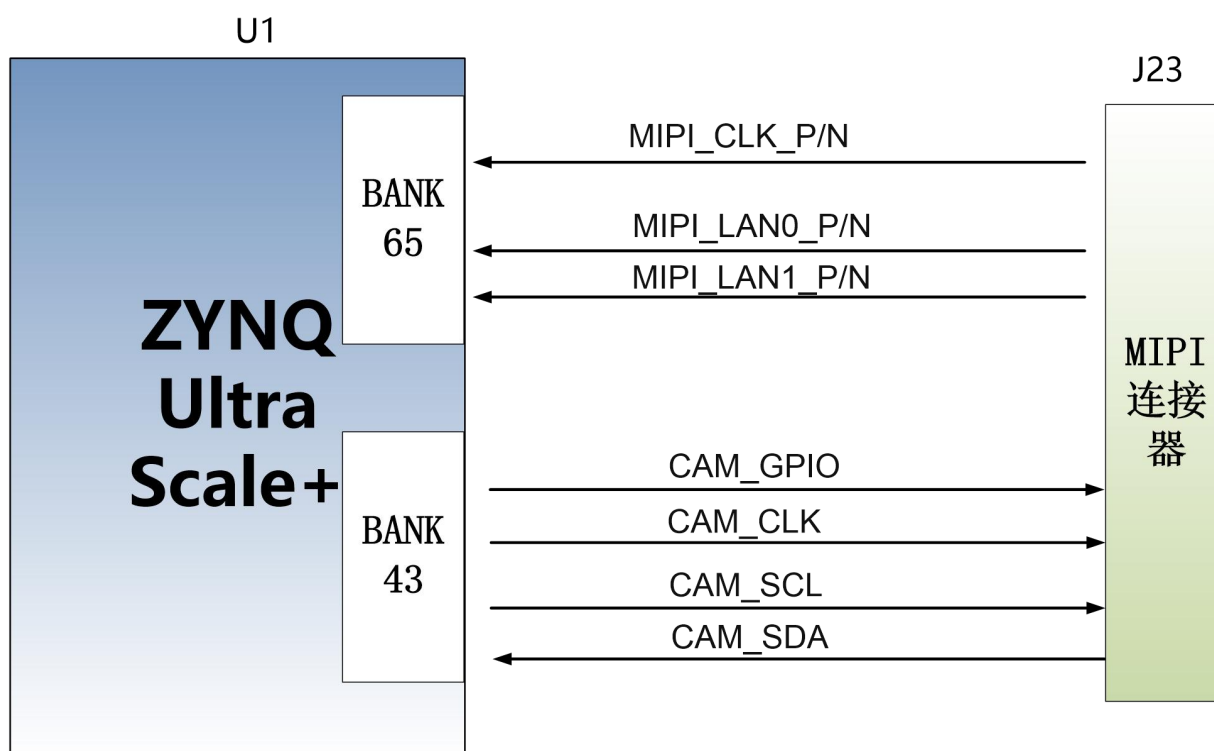

Figure 3-14-1: MIPI camera interface design schematic

MIPI interface pin assignment

Signal Name	ZYNQ Pin Name	ZYNQ Pin Number	Description
MIPI_CLK_P	B65_L1_P	W8	MIPI Input Clock Positive
MIPI_CLK_N	B65_L1_N	Y8	MIPI Input Clock Negative
MIPI_LAN0_P	B65_L2_P	U9	MIPI Input Date LANE0 Positive
MIPI_LAN0_N	B65_L2_N	V9	MIPI Input Date LANE0 Negative
MIPI_LAN1_P	B65_L3_P	U8	MIPI Input Date LANE1 Positive
MIPI_LAN1_N	B65_L3_N	V8	MIPI Input Date LANE1 Negative
CAM_GPIO	B43_L4_P	AE10	GPIO Control of Camera

CAM_CLK	B43_L4_N	AF10	Clock Input of Camera
CAM_SCL	B43_L11_P	Y9	I2C Clock of Camera
CAM_SDA	B43_L11_N	AA8	I2C Data of Camera

Part 3.15: FMC Interface

The AXU5EVB-P FPGA Carrier board has a standard FMC HPC expansion port that can be connected to various FMC modules of XILINX or ALINX (HDMI input and output modules, binocular camera modules, high-speed AD modules, etc.). The FMC expansion port contains 36 pairs of differential IO signals.

The 36 pairs of differential signals of the FMC expansion port are connected to the IO of the BANK65 and BANK66 of the ZYNQ Ultrascale+ chip. The level standard is 1.8V, and the differential signal supports LVDS data communication. The schematic diagram of ZYNQ Ultrascale+ and FMC connectors is shown in Figure 3-15-1.

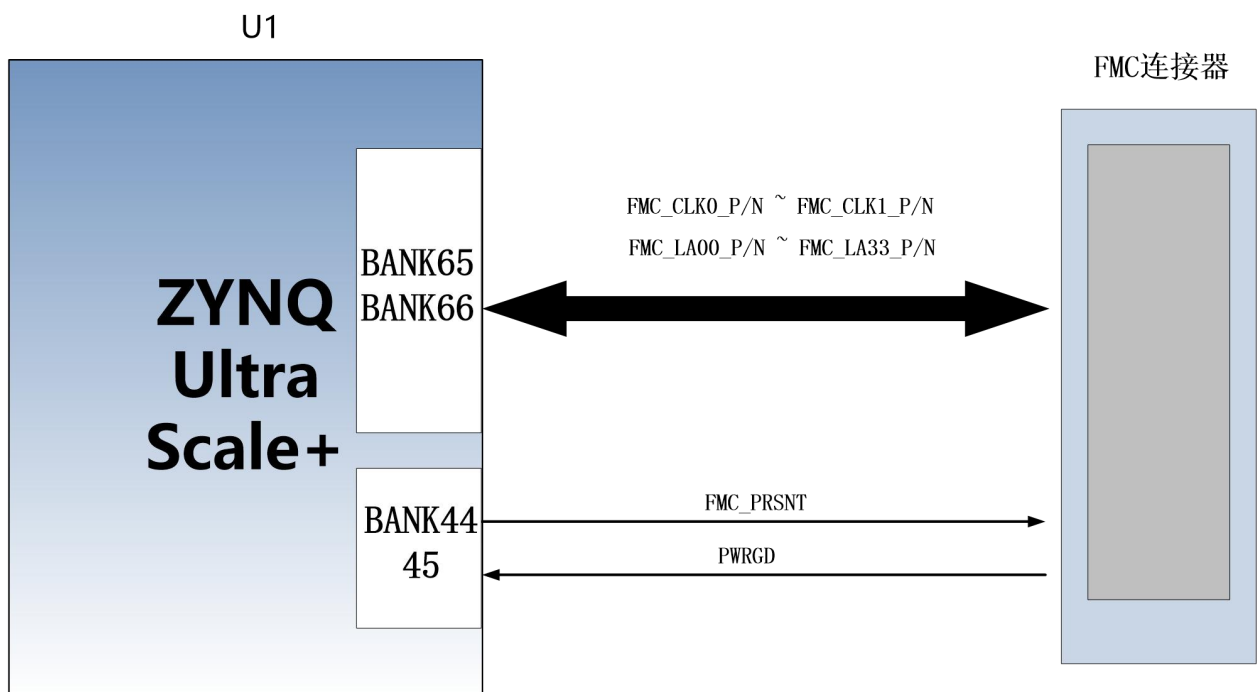

Figure 3-15-1: FMC Schematic

FMC connector pin assignment

Signal Name	ZYNQ Pin Name	ZYNQ Pin	Description
-------------	---------------	----------	-------------

		Number	
FMC_CLK0_P	B65_L11_P	K4	FMC Reference 1 st Reference Clock P
FMC_CLK0_N	B65_L11_N	K3	FMC Reference 1 st Reference Clock N
FMC_CLK1_P	B65_L14_P	M6	FMC Reference 2 nd Reference Clock P
FMC_CLK1_N	B65_L14_N	L5	FMC Reference 2 nd Reference Clock N
FMC_LA00_CC_P	B65_L12_P	L3	FMC Reference 0 th Data (Clock) P
FMC_LA00_CC_N	B65_L12_N	L2	FMC Reference 0 th Data (Clock) N
FMC_LA01_CC_P	B65_L13_P	L7	FMC Reference 1 st Data (Clock) P
FMC_LA01_CC_N	B65_L13_N	L6	FMC Reference 1 st Data (Clock) N
FMC_LA02_P	B65_L10_P	H4	FMC Reference 2 nd Data P
FMC_LA02_N	B65_L10_N	H3	FMC Reference 2 nd Data N
FMC_LA03_P	B65_L4_P	R8	FMC Reference 3 rd Data P
FMC_LA03_N	B65_L4_N	T8	FMC Reference 3 rd Data N
FMC_LA04_P	B65_L7_P	L1	FMC Reference 4 th Data P
FMC_LA04_N	B65_L7_N	K1	FMC Reference 4 th Data N
FMC_LA05_P	B65_L20_P	J6	FMC Reference 5 th Data P
FMC_LA05_N	B65_L20_N	H6	FMC Reference 5 th Data N
FMC_LA06_P	B65_L22_P	K8	FMC Reference 6 th Data P
FMC_LA06_N	B65_L22_N	K7	FMC Reference 6 th Data N
FMC_LA07_P	B65_L16_P	P7	FMC Reference 7 th Data P
FMC_LA07_N	B65_L16_N	P6	FMC Reference 7 th Data N
FMC_LA08_P	B65_L15_P	N7	FMC Reference 8 th Data P
FMC_LA08_N	B65_L15_N	N6	FMC Reference 8 th Data N
FMC_LA09_P	B65_L17_P	N9	FMC Reference 9 th Data P
FMC_LA09_N	B65_L17_N	N8	FMC Reference 9 th Data N
FMC_LA10_P	B65_L6_P	R6	FMC Reference 10 th Data P
FMC_LA10_N	B65_L6_N	T6	FMC Reference 10 th Data N
FMC_LA11_P	B65_L5_P	R7	FMC Reference 11 th Data P
FMC_LA11_N	B65_L5_N	T7	FMC Reference 11 th Data N
FMC_LA12_P	B65_L9_P	K2	FMC Reference 12 th Data P
FMC_LA12_N	B65_L9_N	J2	FMC Reference 12 th Data N
FMC_LA13_P	B65_L21_P	J7	FMC Reference 13 th Data P

FMC_LA13_N	B65_L21_N	H7	FMC Reference 13 th Data N
FMC_LA14_P	B65_L19_P	J5	FMC Reference 14 th Data P
FMC_LA14_N	B65_L19_N	J4	FMC Reference 14 th Data N
FMC_LA15_P	B65_L18_P	M8	FMC Reference 15 th Data P
FMC_LA15_N	B65_L18_N	L8	FMC Reference 15 th Data N
FMC_LA16_P	B65_L23_P	K9	FMC Reference 16 th Data P
FMC_LA16_N	B65_L23_N	J9	FMC Reference 16 th Data N
FMC_LA17_CC_P	B66_L11_P	D4	FMC Reference 17 th Data (Clock) P
FMC_LA17_CC_N	B66_L11_N	C4	FMC Reference 17 th Data (Clock) N
FMC_LA18_CC_P	B66_L12_P	C3	FMC Reference 18 th Data (Clock) P
FMC_LA18_CC_N	B66_L12_N	C2	FMC Reference 18 th Data (Clock) N
FMC_LA19_P	B66_L3_P	F2	FMC Reference 19 th Data P
FMC_LA19_N	B66_L3_N	E2	FMC Reference 19 th Data N
FMC_LA20_P	B66_L2_P	E1	FMC Reference 20 th Data P
FMC_LA20_N	B66_L2_N	D1	FMC Reference 20 th Data N
FMC_LA21_P	B66_L15_P	G6	FMC Reference 21 st Data P
FMC_LA21_N	B66_L15_N	F6	FMC Reference 21 st Data N
FMC_LA22_P	B66_L1_P	G1	FMC Reference 22 nd Data P
FMC_LA22_N	B66_L1_N	F1	FMC Reference 22 nd Data N
FMC_LA23_P	B66_L5_P	E4	FMC Reference 23 rd Data P
FMC_LA23_N	B66_L5_N	E3	FMC Reference 23 rd Data N
FMC_LA24_P	B66_L20_P	C6	FMC Reference 24 th Data P
FMC_LA24_N	B66_L20_N	B6	FMC Reference 24 th Data N
FMC_LA25_P	B66_L4_P	G3	FMC Reference 25 th Data P
FMC_LA25_N	B66_L4_N	F3	FMC Reference 25 th Data N
FMC_LA26_P	B66_L16_P	G8	FMC Reference 26 th Data P
FMC_LA26_N	B66_L16_N	F7	FMC Reference 26 th Data N
FMC_LA27_P	B66_L6_P	G5	FMC Reference 27 th Data P
FMC_LA27_N	B66_L6_N	F5	FMC Reference 27 th Data N
FMC_LA28_P	B66_L10_P	B4	FMC Reference 28 th Data P
FMC_LA28_N	B66_L10_N	A4	FMC Reference 28 th Data N
FMC_LA29_P	B66_L7_P	C1	FMC Reference 29 th Data P
FMC_LA29_N	B66_L7_N	B1	FMC Reference 29 th Data N
FMC_LA30_P	B66_L13_P	D7	FMC Reference 30 th Data P
FMC_LA30_N	B66_L13_N	D6	FMC Reference 30 th Data N
FMC_LA31_P	B66_L9_P	B3	FMC Reference 31 st Data P

FMC_LA31_N	B66_L9_N	A3	FMC Reference 31 st Data N
FMC_LA32_P	B65_L24_P	H9	FMC Reference 32 nd Data P
FMC_LA32_N	B65_L24_N	H8	FMC Reference 32 nd Data N
FMC_LA33_P	B66_L8_P	A2	FMC Reference 33 rd Data P
FMC_LA33_N	B66_L8_N	A1	FMC Reference 33 rd Data N
FMC_PRSENT	B45_L12_N	C12	FMC Module Exist Signal
PWRGD	B44_L2_N	AH14	FMC Power Good Signal

Part 3.16: JTAG Debug Port

The JTAG interface is reserved on the AXU5EVB- P expansion board for downloading ZYNQ UltraScale+ programs or firmware programs to FLASH. In order to not damage the ZYNQ UltraScale+ chip by plugging and unplugging under power, we added a protection diode to the JTAG signal to ensure that the signal voltage is within the range accepted by the FPGA and avoid damage to the ZYNQ UltraScale+ chip.

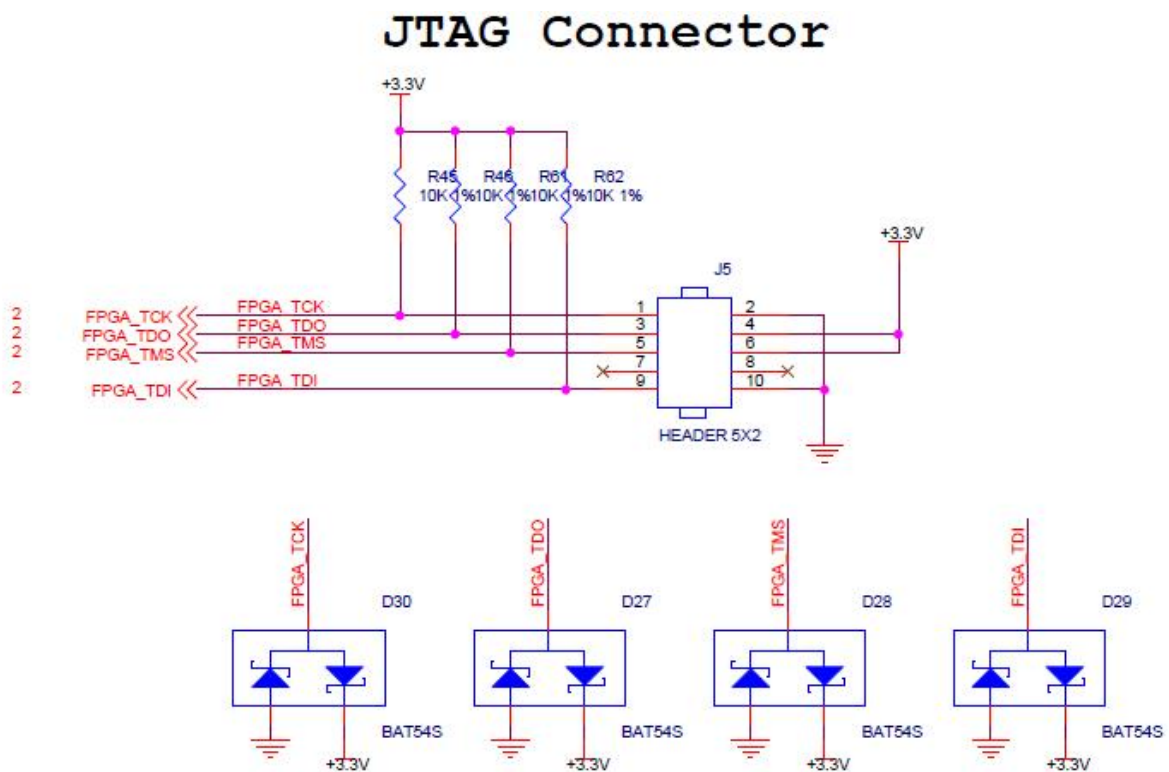

Figure 3-16-1: JTAG Interface Schematic

Part 3.17: Real-time Clock

The ZU4EV chip has the function of an RTC real-time clock, with timing functions such as year, month, day, hour, minute, and second, and week. External need to connect a 32.768KHz passive clock to provide an accurate clock source to the internal clock circuit, so that the RTC can accurately provide clock information. At the same time, in order for the real-time clock to operate normally after the product is powered off, it is generally necessary to equip the coin battery (**model LR1130, voltage is 5V**) to supply power to the clock chip. The BT1 on the development board is a battery Socket. After we put the coin battery, even the system is off, the coin battery can also power the RTC system and provide continuous time information.

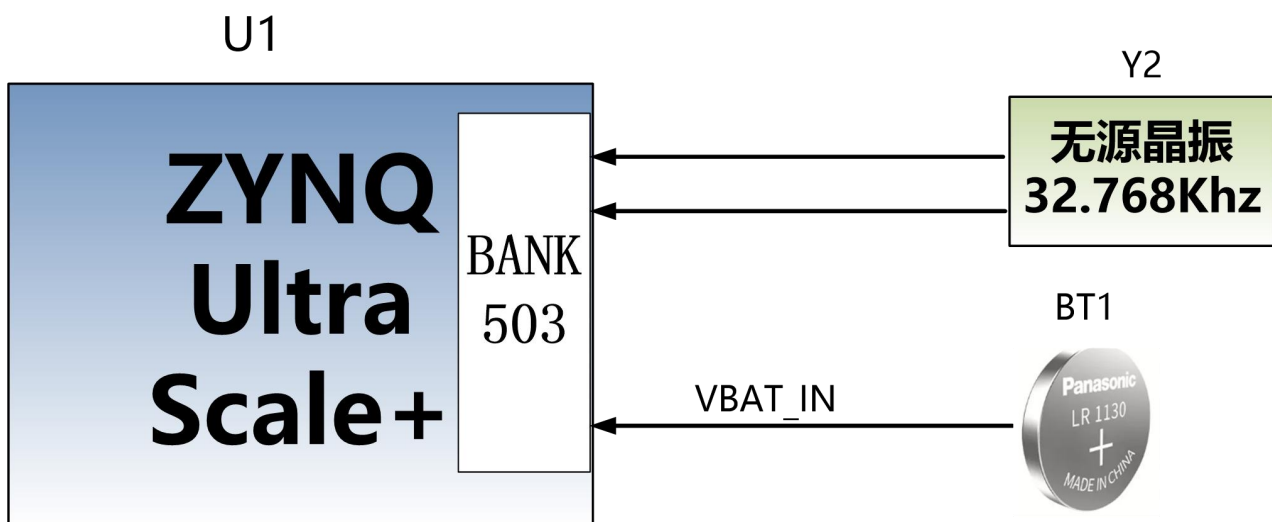

Figure 3-17-1: RTC Schematic

Part 3.18: EEPROM and Temperature Sensor

The AXU5EVB-P FPGA development board has an EEPROM onboard. The model of the EEPROM is 24LC04, and the capacity is: 4Kbit (2 * 256 * 8bit), which is connected to the PS terminal through the I2C bus.

A high-precision, low-power, digital temperature sensor chip is installed on the AXU5EVB-P FPGA development board, and the model is LM75 from ON

Semiconductor. The temperature accuracy of the LM75 chip is 0.5 degrees.

The EEPROM and temperature sensor are mounted on the Bank500 MIO of ZYNQ UltraScale+ through the I2C bus. Figure 3-18-1 is the schematic diagram of EEPROM and temperature sensor

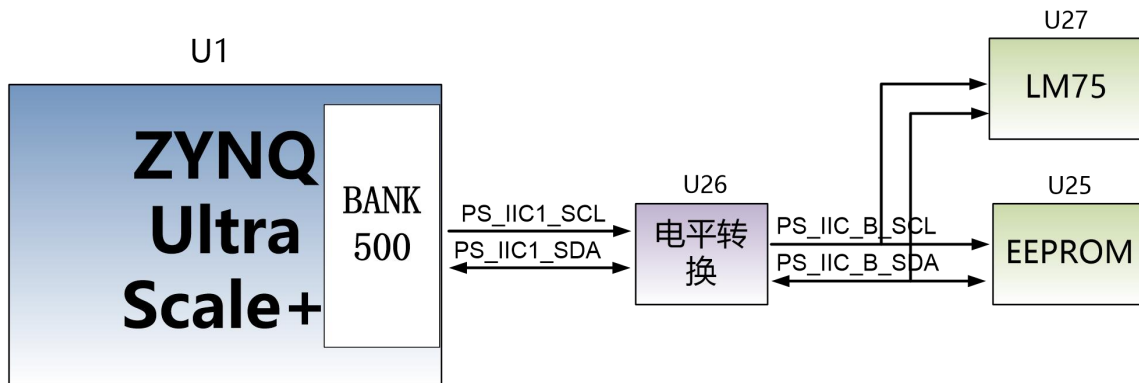

Figure 3-18-1: EEPROM and Sensor connection diagram

EEPROM pin assignment:

Signal Name	ZYNQ Pin Name	ZYNQ Pin Number	Description
PS_IIC1_SCL	PS_MIO24	AB19	I2C Clock Signal
PS_IIC1_SDA	PS_MIO25	AB21	I2C Data Signal

Part 3.19: User LEDs

There are 3 LEDs on the AXU5EVB-P Carrier board. including 1 power indicator light, 1 User LED Controlled by PS side, and 1 User LED Controlled by PL side. The user can control the user LED on and off through the program. When the IO voltage of the connected user LED light is low, the user LED light is off, and when the connected IO voltage is high, the user LED will be lit. The schematic diagram of the user's LED light hardware connection is shown in Figure 3-19-1:

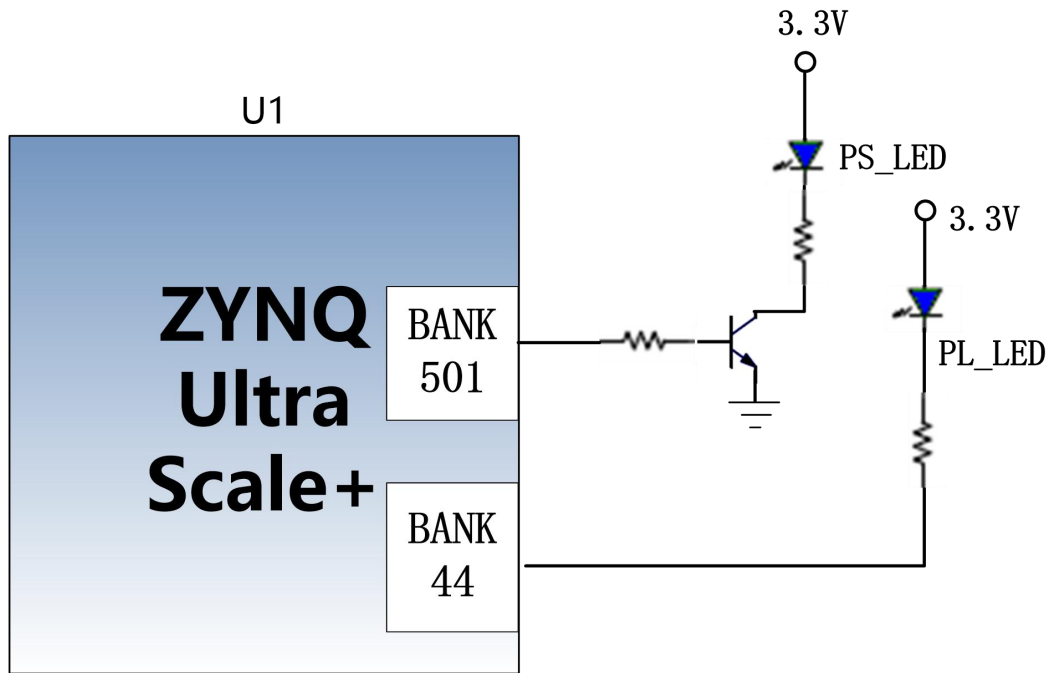

Figure 3-19-1: The User LEDs Hardware Connection Diagram

Pin assignment of user LED lights

Signal Name	ZYNQ Pin Name	ZYNQ Pin Number	Description
PS_LED1	PS_MIO40	K18	User LED controlled by PS
PL_LED1	B44_L1_P	AE15	User LED controlled by PL

Part 3.20: Keys

There are 1 reset KEY RESET and 2 user buttons on the AXU5EV-P carrier board. The reset signal is connected to the reset chip input of the core board ACU4EV, and the user can use this reset KEY to reset the ZYNQ system. One user KEY is connected to the MIO of the PS, and one is connected to the IO of the PL. The reset KEY and the user KEYs are both low-level active. The connection diagram of the user key is shown in Figure 3-20-1:

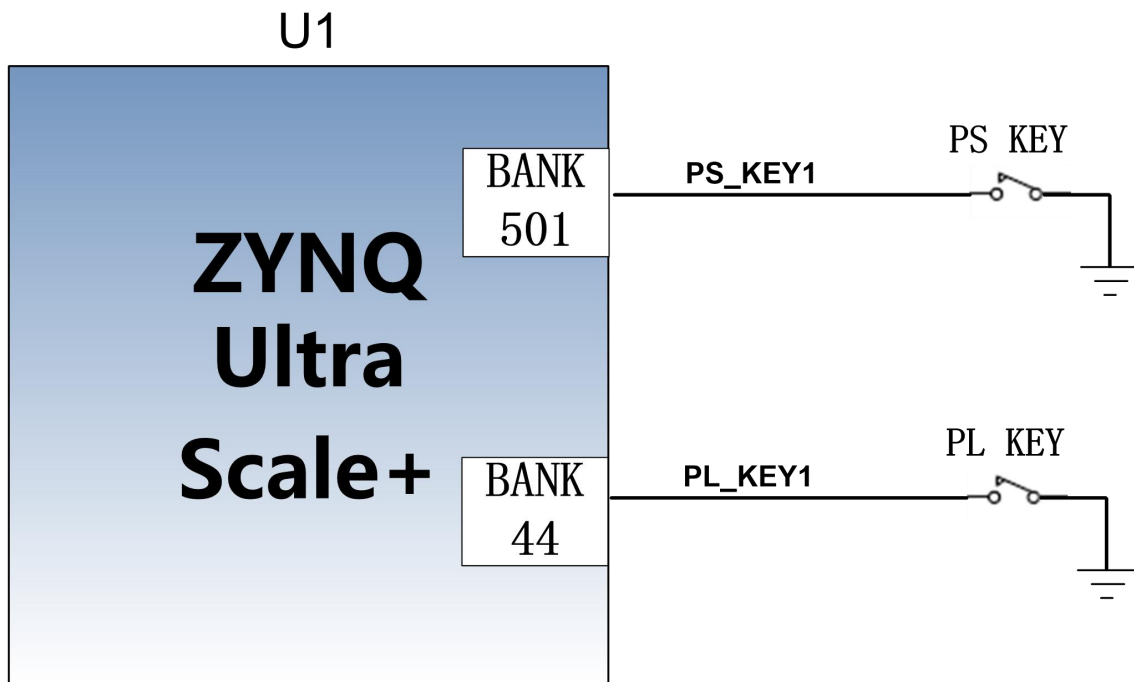

Figure 3-20-1: Rest keys connection diagram

ZYNQ pin assignment of keys

Signal Name	ZYNQ Pin Name	ZYNQ Pin Number	Description
PS_KEY1	PS_MIO26	L15	PS KEY1 Input
PL_KEY1	B44_L1_N	AE14	PL KEY1 Input

Part 3.21: DIP Switch Configuration

There is a 4-digit DIP switch SW1 on the FPGA development board to configure the startup mode of the ZYNQ system. The AXU5EVB-P system development platform supports 4 startup modes. The 4 startup modes are JTAG debug mode, QSPI FLASH, EMMC and SD2.0 card startup mode. After ZU4EV chip is powered on, it will detect the level of (PS_MODE0~3) to determine the startup mode. The user can select different startup modes through the DIP switch SW1 on the expansion board. The SW1 startup mode configuration is shown in the following table 3-21-1.

SW1	Dial Position (1, 2, 3, 4)	MODE[3:0]	Start mode
-----	----------------------------	-----------	------------

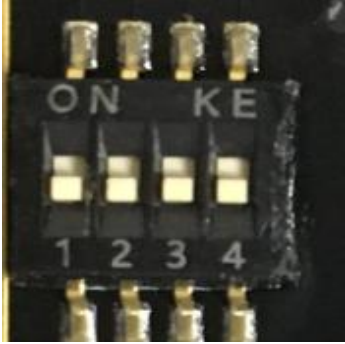
	ON, ON, ON, ON	0000	PS JTAG
	ON, ON, OFF, ON	0010	QSPI FLASH
	ON, OFF, ON, OFF	0101	SD Card
	ON, OFF, OFF, ON	0110	EMMC

Part 3.22: Power Supply

The power input voltage of the AXU5EVB-P development board is DC12V. In the carrier board, the DC12V is converted into +5V, +3.3V, and +1.8V through one-way DC/DC power chip TPS54620 and two-way DC/DC power chip MP1482. In addition, the Carrier board generates +1.2V through LDO to supply power to the core board BANK65 (The power supply of BANK65 is selected by the jumper cap. When debugging MIPI camera, select 1.2V power supply, when using FMC interface, use 1.8V power supply), and the power supply of BANK66 is +1.8V. The schematic diagram of the power supply design on the board is shown in Figure 3-22-1:

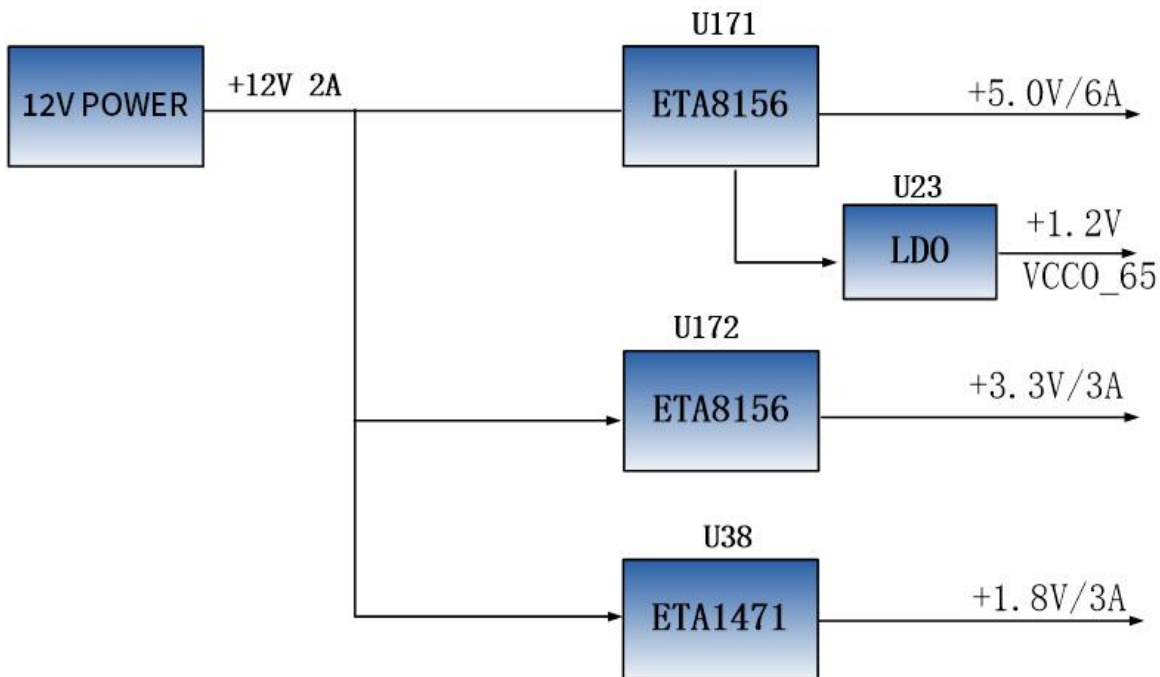

Figure 3-22-1: Carrier Board Power Schematic

The functions of each power distribution are shown in the following table:

Power	Function
+5.0V	USB power supply
+1.8V	Ethernet, USB2.0, BANK66 of Core Board
+3.3V	Ethernet, USB2.0, SD, DP, CAN, RS485
+1.2V	BANK65 of Core Board

Part 3.23: ALINX Customized Fan

Because AXU5EVB-P generates a lot of heat when it works normally, we add a heat sink and fan to the chip on the board to prevent the chip from overheating. The control of the fan is controlled by the ZYNQ chip. The control pin is connected to the IO of the BANK44 (AG14). If the IO level output is high, the MOSFET is turned on and the fan is working. If the IO level output is low, the fan stops. The fan design on the board is shown in Figure 3-23-1.

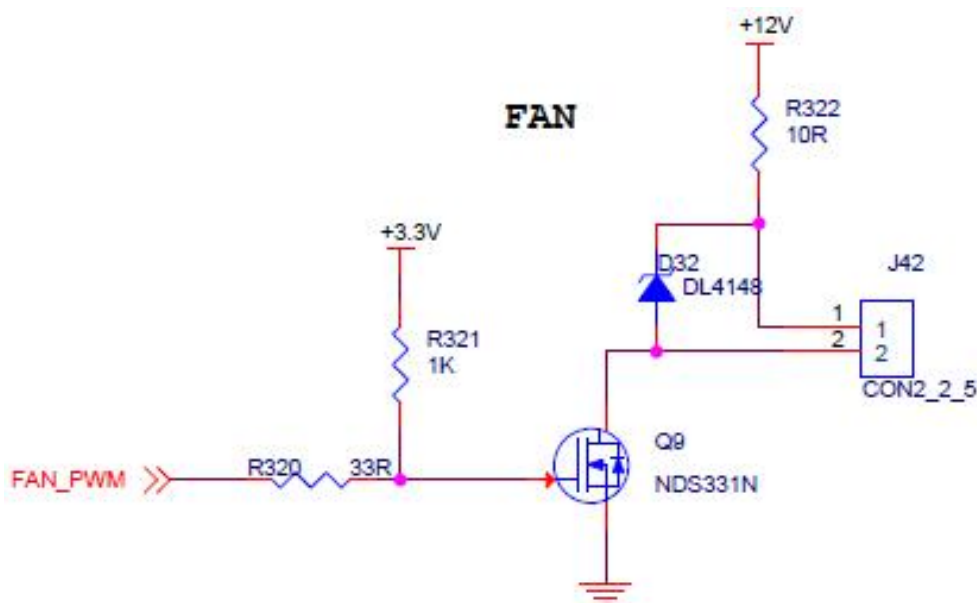

Figure 3-23-1: Fan Design Schematic

The fan has been screwed to the FPGA development board before leaving the factory. The power of the fan is connected to the socket of J42. The red is positive and the black is negative.

Part 3.24: Carrier Board Size Dimension

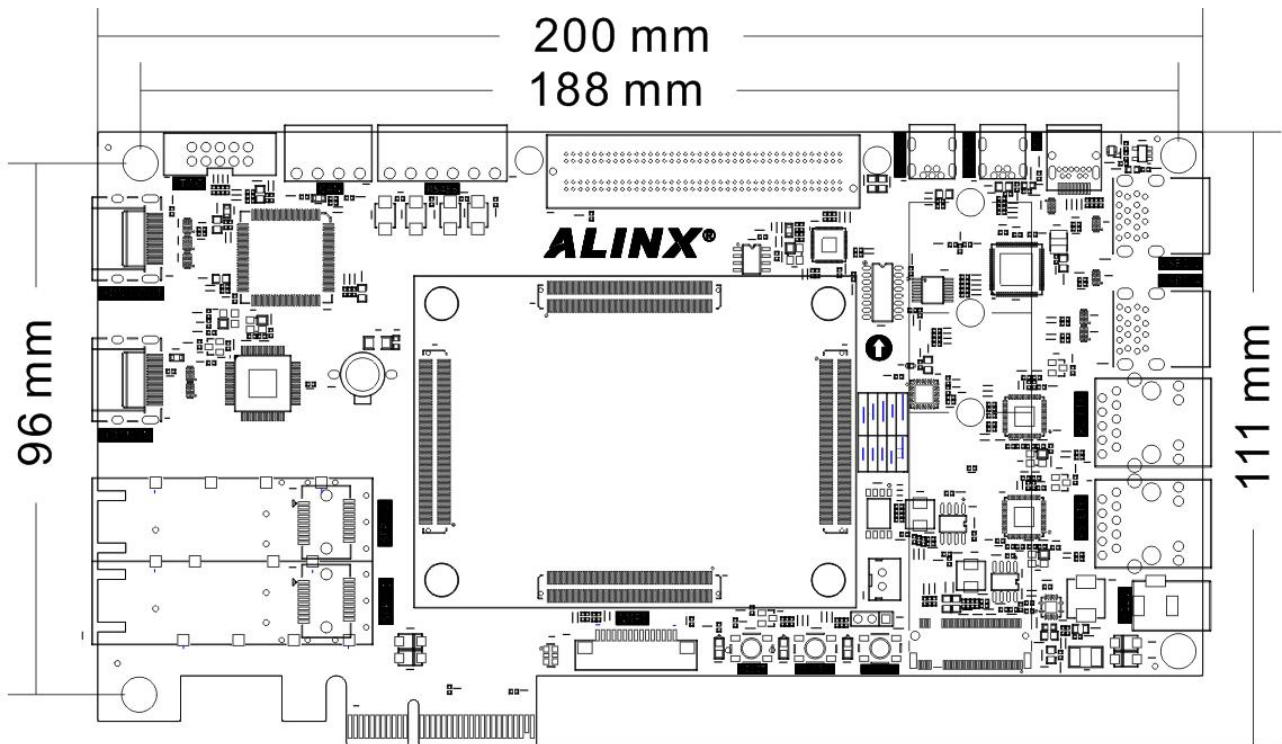

Figure 3-24-1: Top View