

**16-channel GMSL2 On-board  
Camera Acquisition Module  
FH9712  
User Manual**

**Rev 1.0**



## Part 1: Introduction of Module FH9712

FH9712 is a 16-channel GMSL2/GMSL1 camera acquisition module, which uses four decoder chips MAX96712 to decode 16-channel camera videos. The MAX96712 chip is an automotive-grade 4-channel serial decoder that supports 3Gbps and 6Gbps serial speeds and supports the first-generation GMSL1 and second-generation GMSL2 standards. The camera interface uses a 4-in-1 FAKRA coaxial connector.

The four MAX96712 chips are converted into four 4-LANE MIPI signals to connect to the FPGA development board of ALINX through FMC interface to realize the conversion and transmission of video images. The FMC interface is a standard LPC interface that meets the VITA 57.1 standard. The model of the FMC connector is ASP\_134604\_01.

The picture of module FH9712 is as follows:

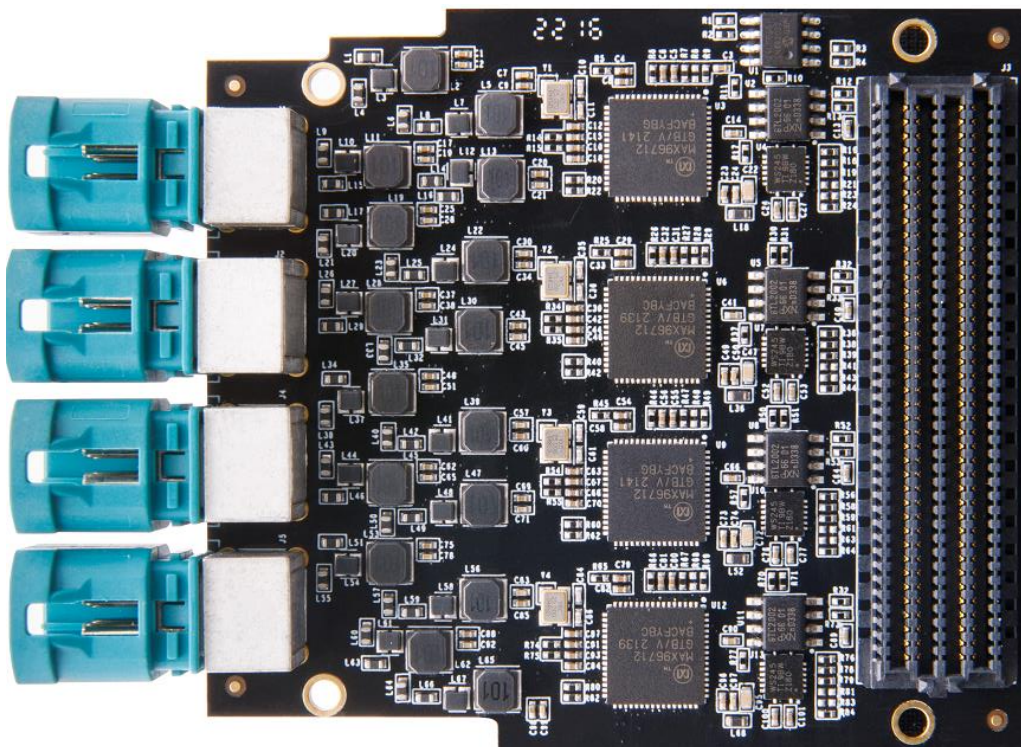

Picture of Module FH9712

## 1.1 Parameters of Module FH9712

### 1) Support multi-channel GMSL1/2 camera input

It supports 16-channel cameras, 8MP resolution cameras as the highest

### 2) Cable length

Up to 40m (3Gbps) in GMSL1 mode

Up to 20 m (6Gbps) in GMSL2 mode

### 3) AG connector

Use Amphenol Z Code FAKRA AG coaxial connectors

### 4) Input image format

It supports RAW8/10/12/14/16/20, RGB565/666/888, YUV422 8/10bit video

image formats. The remote camera can be configured via I2C

### 5) FMC interface

Standard LPC connector, four 4-LANE MIPI CSI-2 v1.3 interface, data rate up to 2500Mbps.

## 1.2 Structure Diagram of Module FH9712

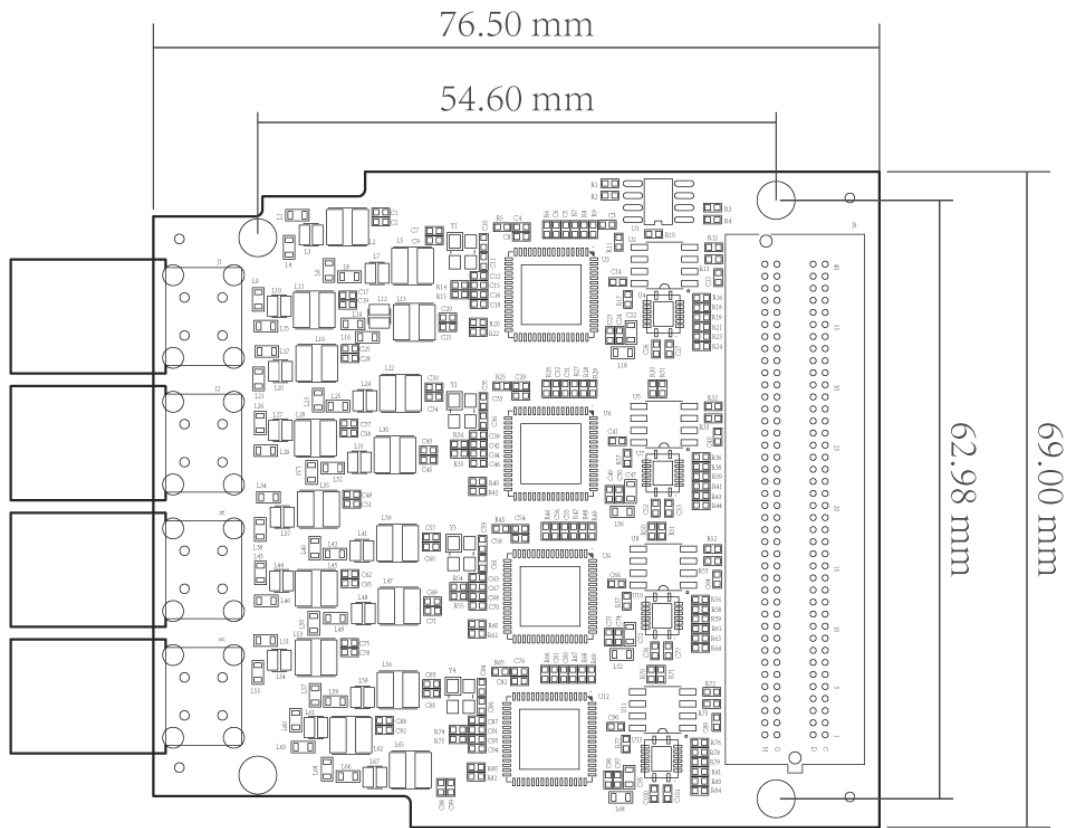

FH9712 Structure Diagram

## Part 2: Functions of Module FH9712

### 2.1 Schematic diagram of the module FH9712

The schematic design diagram of the module FH9712 is as follows:

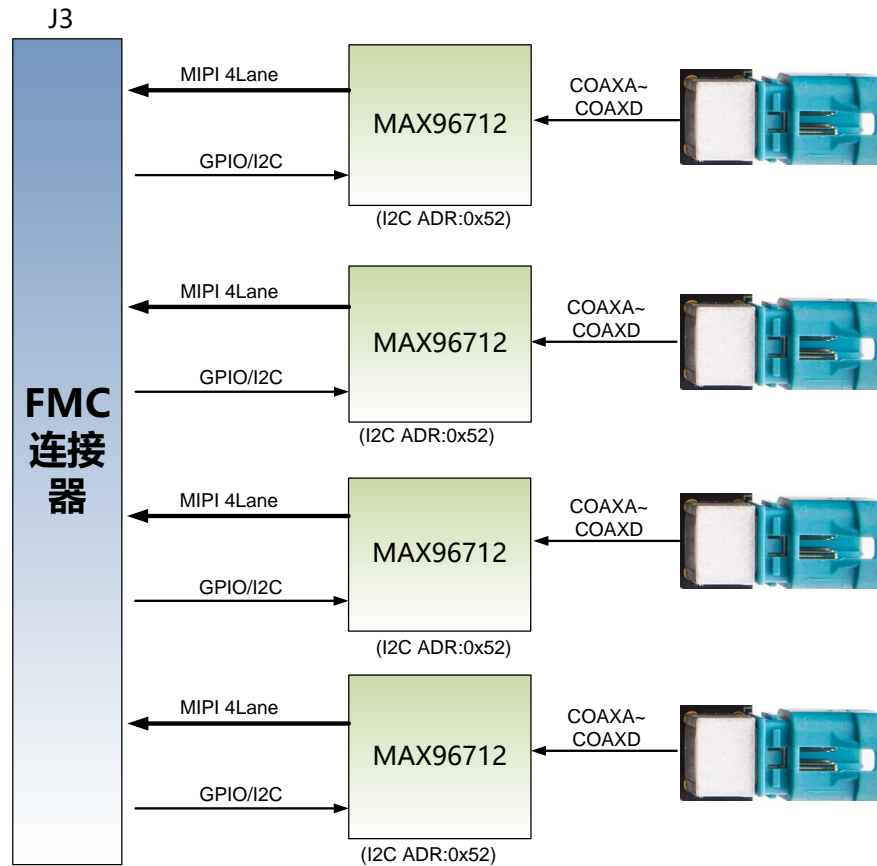

**Design diagram of video input**

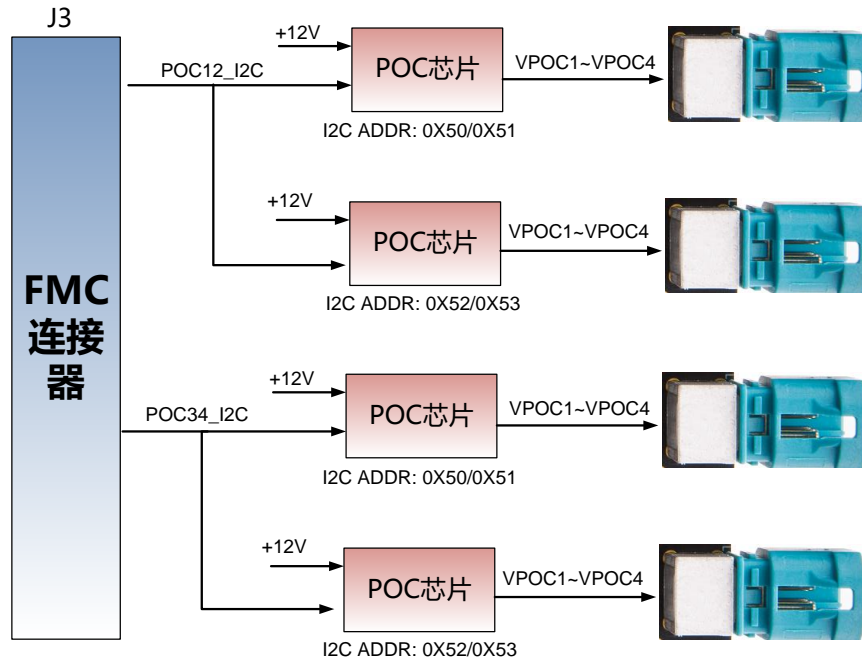

Design diagram of POC power supply

## 2.2 Pin assignment of Module FMC LPC

Only the signals are listed below, and the power and GND signals are not listed. The following figure is the pin assignment of FH9712 and Z7-P development board.

FMC Pin No.	Signal Name	FPGA Pin No.	Description
G15	G1_CKAP	AL20	1 <sup>st</sup> -channel MIPI clock P
G16	G1_CKAN	AL21	1 <sup>st</sup> -channel MIPI clock N
C10	G1_DA0P	AL22	1 <sup>st</sup> -channel MIPI data 0P
C11	G1_DA0N	AL23	1 <sup>st</sup> -channel MIPI data 0N
D14	G1_DA1P	AK22	1 <sup>st</sup> -channel MIPI data 1P
D15	G1_DA1N	AK23	1 <sup>st</sup> -channel MIPI data 1N
G12	G1_DA2P	AJ20	1 <sup>st</sup> -channel MIPI data 2P
G13	G1_DA2N	AK20	1 <sup>st</sup> -channel MIPI data 2N
H13	G1_DA3P	AJ19	1 <sup>st</sup> -channel MIPI data 3P
H14	G1_DA3N	AK19	1 <sup>st</sup> -channel MIPI data 3N
G7	G1_GPI0	AJ22	1 <sup>st</sup> -channel MAX96712 input GPIO
G6	G1_GPI1	AJ21	1 <sup>st</sup> -channel MAX96712 input GPI1
G9	G1_GPI2	AF21	1 <sup>st</sup> -channel MAX96712 input GPI2
G10	G1_GPI3	AF22	1 <sup>st</sup> -channel MAX96712 input GPI3
D8	GMSL1_SCL	AG21	1 <sup>st</sup> -channel MAX96712 I2C clock
D9	GMSL1_SDA	AH21	1 <sup>st</sup> -channel MAX96712 I2C data
H5	G1_PWDN_B	AK17	1 <sup>st</sup> -channel MAX96712 POWER DONW
C18	G2_CKAP	AE18	2 <sup>nd</sup> -channel MIPI clock P

C19	G2_CKAN	AE19	2 <sup>nd</sup> -channel MIPI clock N
H19	G2_DA0P	AA18	2 <sup>nd</sup> -channel MIPI data 0P
H20	G2_DA0N	AB18	2 <sup>nd</sup> -channel MIPI data 0N
G18	G2_DA1P	AC18	2 <sup>nd</sup> -channel MIPI data 1P
G19	G2_DA1N	AD19	2 <sup>nd</sup> -channel MIPI data 1N
D17	G2_DA2P	AD20	2 <sup>nd</sup> -channel MIPI data 2P
D18	G2_DA2N	AE20	2 <sup>nd</sup> -channel MIPI data 2N
H16	G2_DA3P	AB19	2 <sup>nd</sup> -channel MIPI data 3P
H17	G2_DA3N	AC19	2 <sup>nd</sup> -channel MIPI data 3N
H7	G2_GPI1	AN22	2 <sup>nd</sup> -channel MAX96712 input GPIO
H8	G2_GPI0	AP23	2 <sup>nd</sup> -channel MAX96712 input GPI1
H10	G2_GPI2	AM21	2 <sup>nd</sup> -channel MAX96712 input GPI2
H11	G2_GPI3	AN21	2 <sup>nd</sup> -channel MAX96712 input GPI3
C14	GMSL2_SCL	AP19	2 <sup>nd</sup> -channel MAX96712 I2C clock
C15	GMSL2_SDA	AP20	2 <sup>nd</sup> -channel MAX96712 I2C data
H4	G2_PWDN_B	AJ17	2 <sup>nd</sup> -channel MAX96712 POWER DONW
D26	G3_CKAP	AP18	3 <sup>rd</sup> -channel MIPI clock P
D27	G3_CKAN	AP17	3 <sup>rd</sup> -channel MIPI clock N
C26	G3_DA0P	AN13	3 <sup>rd</sup> -channel MIPI data 0P
C27	G3_DA0N	AP13	3 <sup>rd</sup> -channel MIPI data 0N
D23	G3_DA1P	AM18	3 <sup>rd</sup> -channel MIPI data 1P
D24	G3_DA1N	AN18	3 <sup>rd</sup> -channel MIPI data 1N
G24	G3_DA2P	AM14	3 <sup>rd</sup> -channel MIPI data 2P
G25	G3_DA2N	AN14	3 <sup>rd</sup> -channel MIPI data 2N
H25	G3_DA3P	AP16	3 <sup>rd</sup> -channel MIPI data 3P
H26	G3_DA3N	AP15	3 <sup>rd</sup> -channel MIPI data 3N
D21	G3_GPI0	AG18	3 <sup>rd</sup> -channel MAX96712 input GPIO
D20	G3_GPI1	AF18	3 <sup>rd</sup> -channel MAX96712 input GPI1
C22	G3_GPI2	AH18	3 <sup>rd</sup> -channel MAX96712 input GPI2
C23	G3_GPI3	AH17	3 <sup>rd</sup> -channel MAX96712 input GPI3
H22	GMSL3_SCL	AM16	3 <sup>rd</sup> -channel MAX96712 I2C clock
H23	GMSL3_SDA	AM15	3 <sup>rd</sup> -channel MAX96712 I2C data
G3	G3_PWDN_B	AJ15	3 <sup>rd</sup> -channel MAX96712 POWER DONW
G30	G4_CKAP	AD15	4 <sup>th</sup> -channel MIPI clock P
G31	G4_CKAN	AE15	4 <sup>th</sup> -channel MIPI clock N
H37	G4_DA0P	AB16	4 <sup>th</sup> -channel MIPI data 0P
H38	G4_DA0N	AB15	4 <sup>th</sup> -channel MIPI data 0N
G33	G4_DA1P	AC17	4 <sup>th</sup> -channel MIPI data 1P
G34	G4_DA1N	AC16	4 <sup>th</sup> -channel MIPI data 1N
G36	G4_DA2P	AA14	4 <sup>th</sup> -channel MIPI data 2P
G37	G4_DA2N	AB14	4 <sup>th</sup> -channel MIPI data 2N
H34	G4_DA3P	AA16	4 <sup>th</sup> -channel MIPI data 3P
H35	G4_DA3N	AA15	4 <sup>th</sup> -channel MIPI data 3N



G28	G4_GPI0	AK14	4 <sup>th</sup> -channel MAX96712 input GPIO
G27	G4_GPI1	AK15	4 <sup>th</sup> -channel MAX96712 input GPI1
H28	G4_GPI2	AH14	4 <sup>th</sup> -channel MAX96712 input GPI2
H29	G4_GPI3	AJ14	4 <sup>th</sup> -channel MAX96712 input GPI3
H31	GMSL4_SCL	AF16	4 <sup>th</sup> -channel MAX96712 I2C clock
H32	GMSL4_SDA	AF15	4 <sup>th</sup> -channel MAX96712 I2C data
G2	G4_PWDN_B	AJ16	4 <sup>th</sup> -channel MAX96712 POWER DONW
D11	POC12_SCL	AG19	I2C clock of POC12 power chip
D12	POC12_SDA	AG20	I2C data of POC12 power chip
G21	POC34_SCL	AE17	I2C clock of POC34 power chip
G22	POC34_SDA	AF17	I2C data of POC34 power chip
C30	FMC_SCL	M10	I2C clock of FMC
C31	FMC_SDA	L10	I2C data of FMC

## Part 3: Installation of FMC Module

At present, FH9712 module can only be adapted to three development boards: Z7-P, Z19 and Z19-P. The following is the installation diagram of FH9712 module and Z7-P.

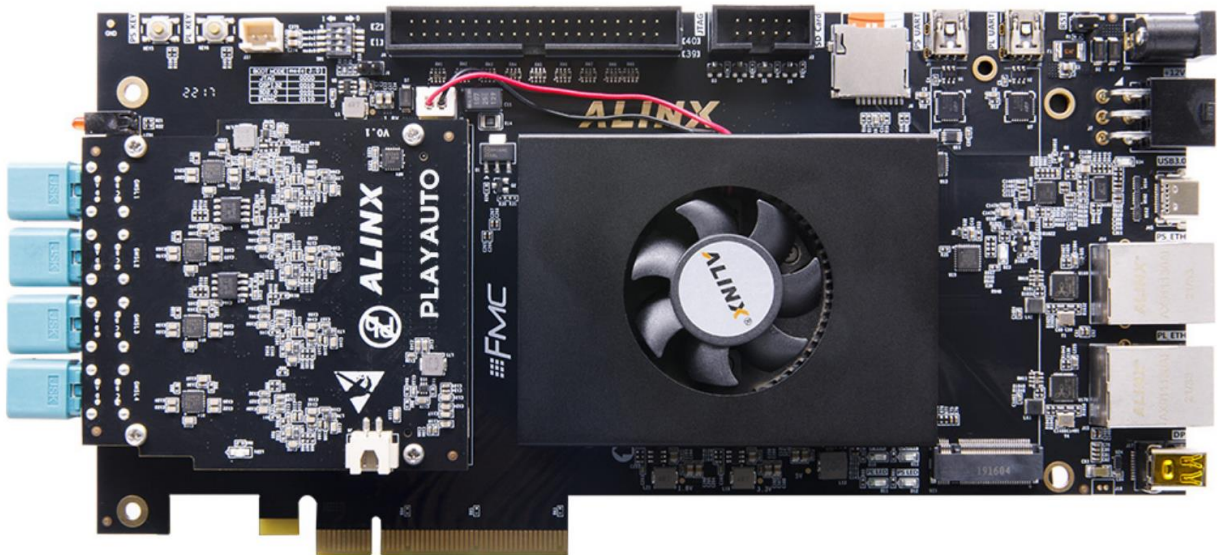

The images acquired by 16-channel videos are transmitted through PCIe, displayed and analyzed by AI on the computer interface.



