

### Description

The BP3166B is a high precision primary-side feedback and regulation controller for LED lighting, it operates in constant current control mode and is designed to work in inductor current discontinuous conduction mode and especially suitable for flyback convertor under universal input.

The BP3166B integrates a 650V power MOSFET, with patent pending MOSFET driving technique. It doesn't need the auxiliary winding for VCC supply. It can achieve excellent constant current performance with very few external components, so the system cost and size are minimized.

The BP3166B offers rich protections to improve the system reliability, including LED short circuit protection, thermal regulation function.

### Features

- No VCC capacitor and no starting resistance
- Integrated HV JFET for Power Supply
- No Auxiliary winding for sensing and supplying
- Universal input voltage
- ±5% LED Output Current Accuracy
- LED Short Protection
- LED Open Protection
- Thermal regulation function
- Package: SOP7

### Applications

- LED Bulb
- LED Candle Light
- Other LED Lighting

### Typical Application

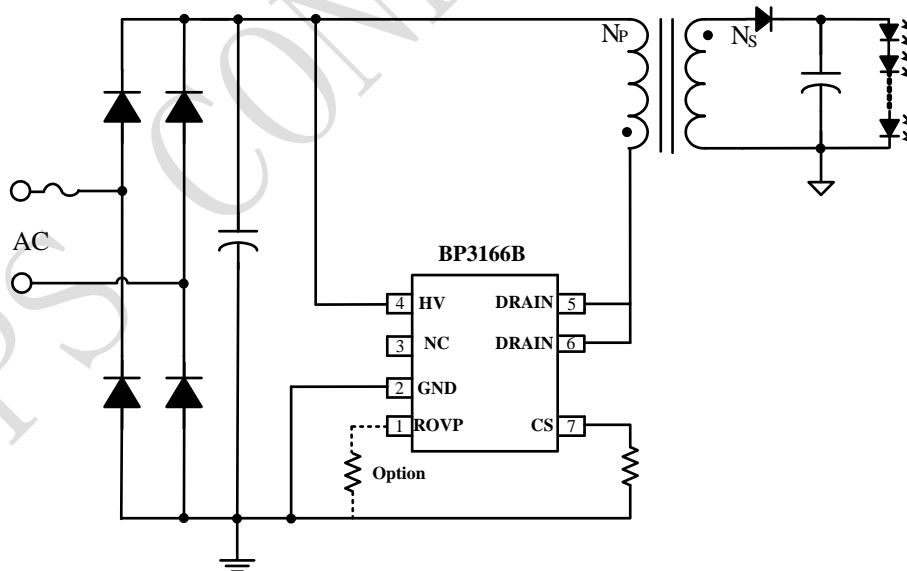

Figure 1. Typical application circuit for BP3166B

## Ordering Information

Part Number	Package	Operating Temperature	Packing Method	Marking
BP3166B	SOP7	-40°C to 105°C	Tape 4,000 Piece/Reel	BP3166B XXXXXX FGXXWWX

## Pin Configuration and Marking Information

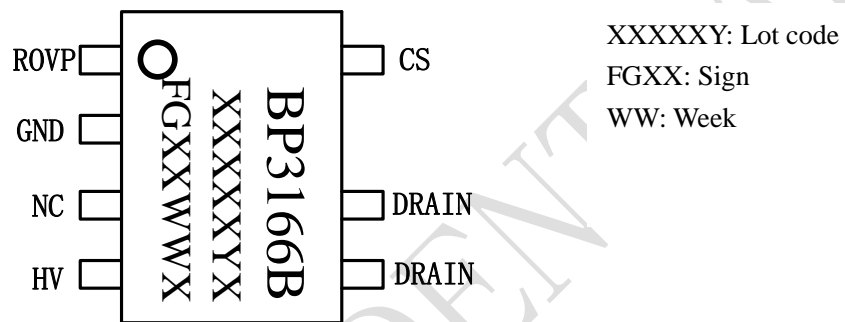

Figure 2. Pin configuration

## Pin Definition

Pin Number	Name	Description
1	ROVP	Over Voltage Protection Setting Pin. Connect a resistor to GND
2	GND	Ground
3	NC	No connection, must be floated
4	HV	Internal high voltage JEFT
5, 6	DRAIN	Internal high voltage MOSFET Drain
7	CS	Current Sense Pin. Connect a sense resistor between this pin and GND.

## Absolute Maximum Ratings (note1)

Symbol	Parameters	Range	Units
HV	650V high voltage power supply JFET	650	V
DRAIN	650V high voltage MOSFET Drain	650	V
IPK-MAX	Maximum leakage current @ TJ=100°C	0.42	A
CS	Current sense pin input voltage	-0.3~6	V
ROVP	Over-voltage setting pin voltage	-0.3~6	V
P <sub>DMAX</sub>	Power dissipation (note2)	0.45	W
θ <sub>JA</sub>	Thermal resistance (Junction to Ambient)	145	°C/W
T <sub>J</sub>	Operating junction temperature	-40 to 150	°C
T <sub>STG</sub>	Storage temperature range	-55 to 150	°C
	ESD (note3)	2	KV

**Note 1:** Stresses beyond those listed under “absolute maximum ratings” may cause permanent damage to the device. Under “recommended operating conditions” the device operation is assured, but some particular parameter may not be achieved. The electrical characteristics table defines the operation range of the device, the electrical characteristics is assured on DC and AC voltage by test program. For the parameters without minimum and maximum value in the EC table, the typical value defines the operation range, the accuracy is not guaranteed by spec.

**Note 2:** The maximum power dissipation decrease if temperature rise, it is decided by  $T_{JMAX}$ ,  $\theta_{JA}$ , and environment temperature ( $T_A$ ). The maximum power dissipation is the lower one between  $P_{DMAX} = (T_{JMAX} - T_A) / \theta_{JA}$  and the number listed in the maximum table.

**Note 3:** Human Body mode, 100pF capacitor discharge on 1.5kΩ resistor.

## Recommended Operation Conditions

Symbol	Parameter	Range	Unit
P <sub>OUT1</sub>	Output power (input voltage 230V ±15%)	< 7	W
P <sub>OUT2</sub>	Output power (input voltage 85V~265V)	< 5	W
F <sub>OP</sub>	System operating frequency	65~70	kHz

**Electrical Characteristics (Notes 4, 5) (Unless otherwise specified,  $T_A=25\text{ }^\circ\text{C}$ )**

Symbol	Parameter	Conditions	Min.	Typ.	Max.	Units
<b>Supply Voltage Section</b>						
$I_{OP}$	$V_{CC}$ operating current	Fop=4.5kHz		200	300	$\mu\text{A}$
<b>Current Sense Section</b>						
$V_{CS\_TH}$	Threshold voltage for peak current limit		368	380	392	mV
$T_{LEB}$	Leading edge blanking time for current sense			500		ns
$T_{DELAY}$	Switch off delay time			200		ns
<b>Internal time control</b>						
$T_{OFF\_MAX}$	Maximum demagnetization time			220		$\mu\text{s}$
$T_{OVP\_RST}$	OVP resetting time			60		ms
<b>MOSFET Section</b>						
$R_{DS\_ON}$	Static drain-source on-resistance	$V_{GS}=10\text{V}/I_{DS}=0.4\text{A}$		14		$\Omega$
$BV_{DSS}$	Drain-source breakdown voltage	$V_{GS}=0\text{V}/I_{DS}=250\mu\text{A}$	650			V
$I_{DSS}$	Drain-source leakage current	$V_{GS}=0\text{V}/V_{DS}=650\text{V}$			1	$\mu\text{A}$
<b>Over Temperature Protection</b>						
$T_{REG}$	Thermal shutdown threshold			140		$^\circ\text{C}$

*Note 4: production testing of the chip is performed at 25  $^\circ\text{C}$ .*

*Note 5: the maximum and minimum parameters specified are guaranteed by test, the typical value are guaranteed by design, characterization and statistical analysis*

## Internal Block Diagram

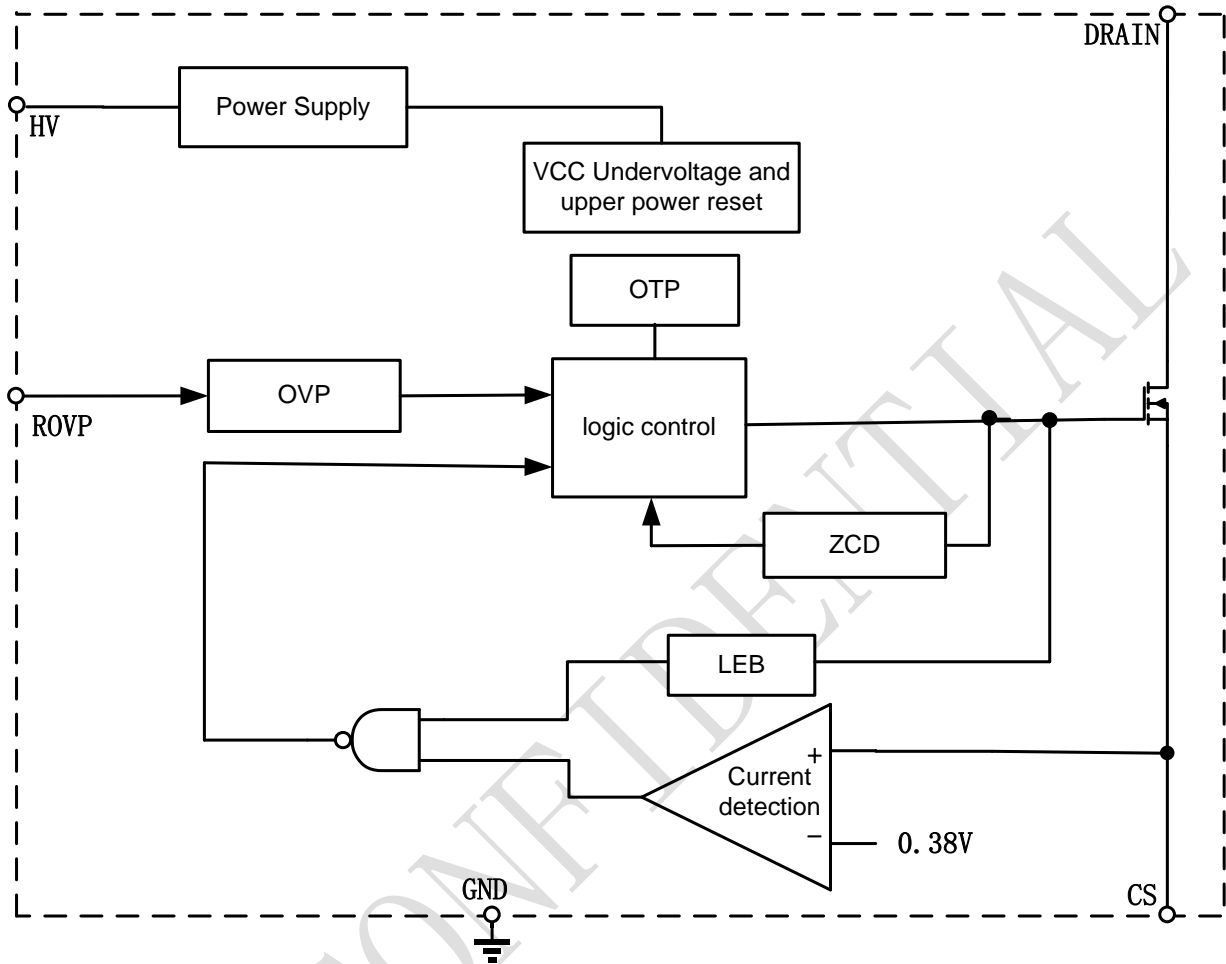

## Application Information

The BP3166B is a high precision primary-side feedback and regulation controller for LED lighting. The device integrates a 650V power MOSFET. With very few external components, the converter achieves excellent constant current control. And it does not need auxiliary winding for powering the IC or voltage sensing, hence the system size and cost is greatly reduced.

### Start Up

After system powered on, through the HV pin the internal power supply voltage reaches the startup threshold, the chip control circuit starts to work.

When the chip is operating normally, the required operating current is still supplied through the internal JFET.

### Constant Current Control

Cycle by Cycle current sense is adopted in BP3166B, the CS pin is connected to the current sense comparator, and the voltage on CS pin is compared with the internal threshold reference voltage. The MOSFET will be switched off when the voltage on CS pin reaches the threshold. The CS comparator includes a 500ns leading edge blanking time.



# BP3166B

晶丰明源半导体

## High Precision PSR Constant Current LED Driver

The primary peak current is given by:

$$I_{P\_PK} = \frac{0.38}{R_{CS}}$$

The current in LED can be calculated by the equation:

$$I_{LED} = \frac{I_{P\_PK}}{4} \times \frac{N_P}{N_S}$$

Where,

$N_P$ : Primary winding turns of transformer

$N_S$ : Secondary winding turns of transformer

$I_{P\_PK}$ : Peak current in the MOSFET

### Operating Switching Frequency

The BP3166B is designed to work in discontinuous conduction mode and no external loop compensation component is required while maintaining stability. The maximum duty cycle is limited to 42%. The maximum frequency of the proposed setup is 65kHz~ 70kHz. If the frequency is set too high, it will affect the number of maximum series LED lamps. If set too low, the LED open circuit voltage will be too high.

The maximum and minimum switching frequency is limited in BP3166B to ensure the stability of system.

The switching frequency can be set by the formula:

$$f = \frac{N_P^2 \times V_{LED}}{8 \times N_S^2 \times L_P \times I_{LED}}$$

Where,  $L_P$  is the primary winding inductance of transformer.

### Protection function

The BP3166B has multiple protection functions, including LED open/short protection, over temperature protection, etc.

When the LED opens, the system will trigger the overvoltage protection logic and lock the system to stop the switch. After 60ms, the system reset and begin to work again.

When LED short, the system works at 4.5kHz low frequency, so power consumption is very low.

The BP3166B through the over-temperature adjustment circuit to detect the chip junction temperature, when the junction temperature exceeds 140 °C , the chip into the over-temperature regulation state, gradually reduce the output current, thus controlling the output power and temperature, the chip temperature control at a certain value to improve System reliability. When the chip junction temperature reaches 160 °C , the MOSFET is immediately turned off until the junction temperature drops 25 °C , the system will exit the overheat protection state, to return to normal work.

### Over Voltage Protection

When ROVP is floating or ROVP resistors are greater than 200k, IC default  $T_{ovp}=4.5$  us. The  $T_{ovp}$  can be set by the resistance value of the ROVP, and the current of the ROVP is about 50uA.

When the LED is open , the output voltage increases gradually, and the demagnetization time gets shorter. The demagnetization time at OVP----  $T_{ovp}$  can be calculated by the open circuit protection voltage:

$$T_{ovp} \approx \frac{L_P \times V_{cs}}{N_{ps} \times R_{cs} \times V_{ovp}}$$

Where,

$L_m$  is the inductance of primary inductor

$V_{cs}$  is the CS pin turn off threshold (380mV)

$N_{ps}$  is the turn ratio between primary and secondary

$V_{ovp}$  is the open circuit protection voltage

And then the  $R_{ovp}$  resistor value can be calculated by the equation:

$$R_{ovp} \approx \frac{100}{T_{ovp}} * 10^{-3}$$

Note: If set ROVP between 25kohms and 200kohms, no OVP.



## PCB Layout

The following rules should be followed in BP3166B

PCB layout:

### Ground Path

The power ground path for current sense should be short, and the power ground path should be separated from small signal ground path before the negative of the bulk capacitor.

### The Area of Power Loop

The area of main current loop should be as small as possible to reduce EMI radiation, such as the primary current loop, the snubber circuit and the secondary rectifying loop.

### NC Pin

NC pin is for safety space.

### Drain pin

To increase the copper area of drain for thermal consideration.

BPS CONFIDENTIAL

## Physical Dimensions

