

Description

The BP3236C is a high efficiency TRIAC dimmable LED driver. The device operates in critical conduction mode and is suitable for buck, buck-boost or fly-back LED lighting.

The BP3236C integrates a 500V power MOSFET. It utilizes patent pending MOSFET driving technique and current sensing method. The operating current of the IC is very low. With very few external components count, it can achieve excellent constant current performance, so the system cost and size are greatly reduced. BP3236C

The BP3236C offers rich protection functions to improve the system reliability, including LED open circuit protection, LED short circuit protection, VCC under voltage protection and thermal regulation function.

The BP3236C is available in a SOP-8 Package.

Features

- TRIAC dimmable
- Integrated 500V Power MOSFET
- Critical Conduction Mode Operation
- Internal JFET Power Supply
- Ultra Low Operating Current
- $\pm 5\%$ LED Output Current Accuracy
- Line Voltage Compensation
- LED Open Protection
- LED Short Protection
- VCC Under Voltage Protection
- External NTC Resistor Setting Thermal Regulation
- Thermal Regulation Function
- Available in SOP-8 Package

Applications

- LED Candle Light
- LED Bulb
- Other LED Lighting

Typical Application

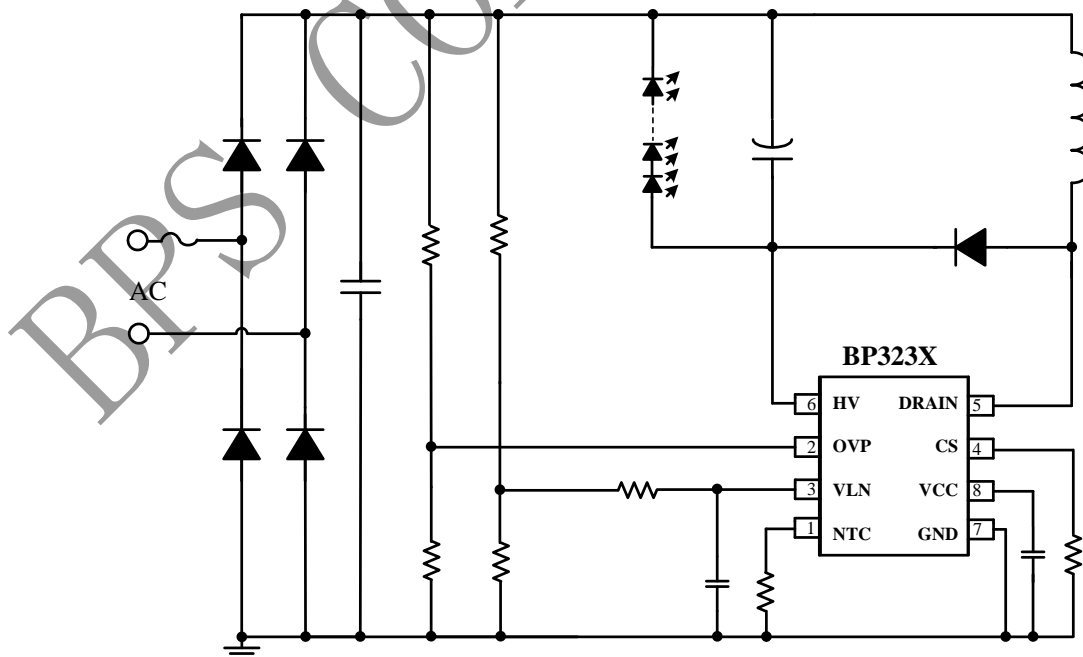

Figure 1. Typical application circuit for BP3236C (Buck-Boost)

Ordering Information

Part Number	Package	Operating Temperature	Packing Method	Marking
BP3236C	SOP8	-40 °C to 105 °C	Tape 4,000 Piece/Reel	BP3236 XXXXXY WWXYC

Pin Configuration and Marking Information

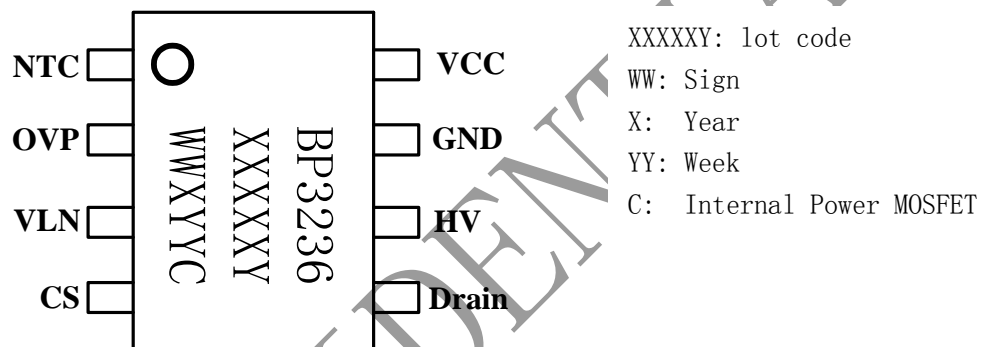

Figure 2. Pin configuration

Pin Definition

Pin No.	Name	Description
1	NTC	External Thermal Regulation Pin, Connect NTC resistor between NTC Pin and GND. NTC Pin can be Floating If Not Use.
2	OVP	Over Voltage Protection Detecting Pin.
3	VLN	Line Voltage Detecting Pin. Connect to 2V voltage reference If Not Use.
4	CS	Current Sense Pin. Connect a sensing resistor between CS and GND pin.
5	DRAIN	Internal HV Power MOSFET Drain.
6	HV	High Voltage Power Supply Pin,
7	GND	IC Ground.
8	VCC	IC Power supply.

Absolute Maximum Ratings (note 1)

Symbol	Parameters	Range	Units
HV	HV pin break down voltage	700	V
DRAIN	Internal HV MOSFET drain to source voltage	-0.3~500	V
CS	Current sense pin input voltage	-0.3~6	V
OVP	Over voltage protection detecting pin voltage	-0.3~6	V
VLN	Line voltage detecting pin voltage	-0.3~6	V
NTC	External NTC resistor voltage detecting pin voltage	-0.3~6	V
P _{DMAX}	Power dissipation (note 2)	0.45	W
θ _{JA}	Thermal resistance (Junction to Ambient)	145	°C/W
T _J	Operating junction temperature	-40 to 150	°C
T _{STG}	Storage temperature range	-55 to 150	°C

Note 1: Stresses beyond those listed under “absolute maximum ratings” may cause permanent damage to the device. Under “recommended operating conditions” the device operation is assured, but some particular parameter may not be achieved. The electrical characteristics table defines the operation range of the device, the electrical characteristics is assured on DC and AC voltage by test program. For the parameters without minimum and maximum value in the EC table, the typical value defines the operation range, the accuracy is not guaranteed by spec.

Note 2: The maximum power dissipation decrease if temperature rise, it is decided by T_{JMAX} , θ_{JA} , and environment temperature (T_A). The maximum power dissipation is the lower one between $P_{DMAX} = (T_{JMAX} - T_A) / \theta_{JA}$ and the number listed in the maximum table.



晶丰明源半导体

High Efficiency TRIAC dimmable LED Driver

BP3236C

Electrical Characteristics (Notes 4, 5) (Unless otherwise specified, $V_{CC}=10V$ and $T_A=25^\circ C$)

Symbol	Parameter	Conditions	Min	Typ	Max	Units
Supply Voltage Section						
V_{CC_CLAMP}	VCC Clamp Voltage	1mA		15		V
V_{CC_ON}	VCC Turn On Threshold	Vcc Rising		10		V
V_{CC_UVLO}	VCC Turn off Threshold	Vcc Falling		7.5		V
I_{ST}	VCC Startup Current	$V_{CC}=V_{CC_ON}-1V$		30	50	uA
I_{OP}	VCC Operating Current			200	300	uA
JFET						
I_{SINK}	JFET Current	$V_{CC}<7.5V$		3		mA
I_{VCC}	VCC Charge Current			3		mA
Current Sense Section						
V_{CS_TH}	Threshold Voltage for Peak Current Limit	$V_{LN}=3.7V$	318	330	342	mV
V_{CS_SHORT}	Threshold Voltage for Peak Current Limit When Output Short	Output Short		200		mV
T_{LEB}	Leading Edge Blanking Time for Current Sense			350		ns
T_{DELAY}	Switch Off Delay Time			200		ns
V_{VLN_TH}	Line Voltage Feed Forward Threshold			3		V
NTC Section						
I_{NTC}	NTC Internal Current Source		45	50	55	uA
V_{NTC}	NTC Internal Reference Voltage			500		mV
Internal Time Control Section						
T_{OFF_MIN}	Minimum OFF Time			2.5		us
T_{OFF_MAX}	Maximum OFF Time			200		us
T_{ON_MAX}	Maximum On Time			8		us
Over Voltage Protection Section						
V_{OVP}	Over Voltage Protection Threshold			1		V
MOSFET Section						
R_{DS_ON}	Static Drain-source On-resistance	$V_{GS}=10V/I_{DS}=0.5A$		3		Ω
BV_{DSS}	Drain-Source Breakdown Voltage	$V_{GS}=0V/I_{DS}=250uA$	500			V
I_{DSS}	Power MOSFET Drain Leakage Current	$V_{GS}=0V/V_{DS}=500V$			1	uA
Thermal Regulation Section						
T_{REG}	Thermal Regulation Temperature			150		$^\circ C$

Note 4: production testing of the chip is performed at 25°C.

Note 5: the maximum and minimum parameters specified are guaranteed by test, the typical value are guaranteed by design, characterization and statistical analysis

Internal Block Diagram

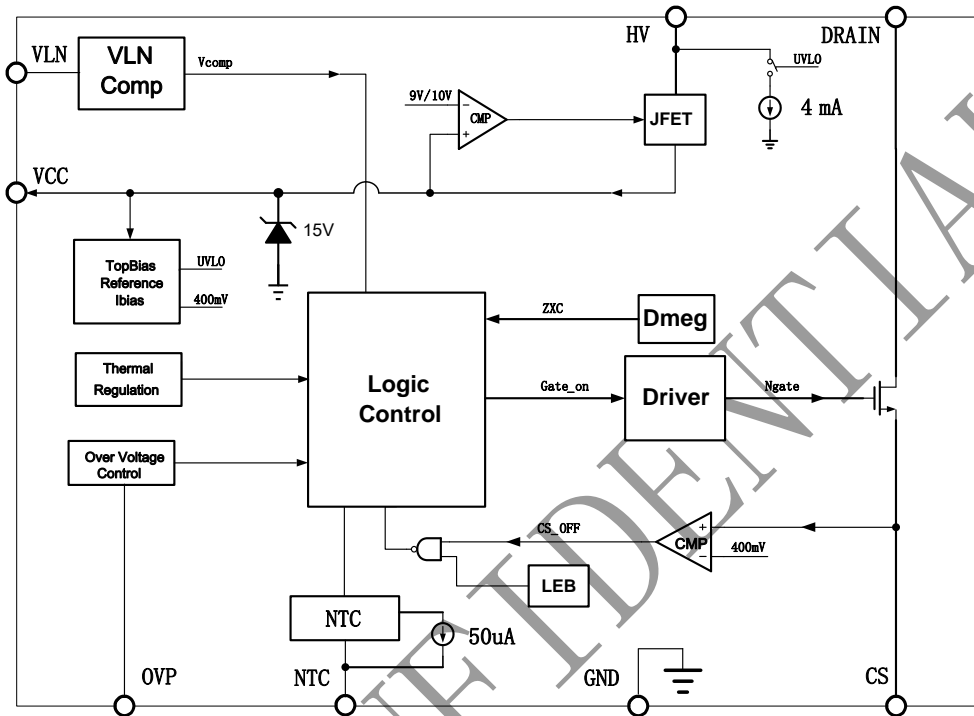

Figure 3. BP3236C Internal Block Diagram

Application Information

The BP3236C is a high efficiency TRIAC dimmable LED driver IC, specially designed for Buck, Buck-boost or Fly-back LED lighting. The BP3236C integrates a 500V power MOSFET. Utilizing patent pending MOSFET driving technique, it can achieve excellent constant current performance with very few external components count, so the system cost and size are greatly reduced.

Start Up

After system powered up, the VCC pin capacitor is charged up by internal JFET. When the VCC pin voltage reaches the turn on threshold, the internal circuits start operating. The BP3236C integrates an 15V zener diode to clamp the VCC voltage. When

VCC voltage is higher than $V_{CC_CHARGE_OFF}$, JFET stop working, when VCC voltage is lower than $V_{CC_CHARGE_ON}$, JFET start charge VCC capacitor. Below is VCC voltage waveform.

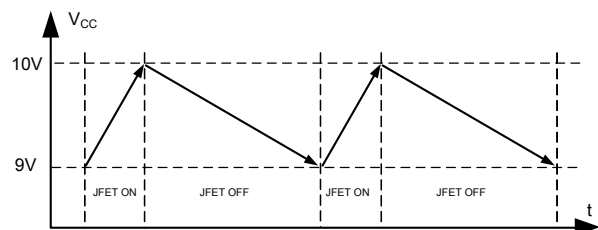

Figure 4. VCC voltage waveform

Constant Current Control

Cycle by Cycle current sense is adopted in BP3236C, the CS pin is connected to the current sense comparator, and the voltage on CS pin is compared with the internal 400mV reference voltage. The MOSFET will be switched off when the voltage on CS pin reaches the threshold.

The peak inductor current is given by:

$$I_{PK} = \frac{400}{R_{CS}} \text{ (mA)}$$

Where, R_{CS} is the current sense resistor value.

The CS comparator includes a 350ns leading edge blanking time.

The VLN pin detects the TRIAC dimmer conducting angle to adjust the LED driver output current. The application circuit of the VLN pin is shown in Figure 4. When the VLN pin voltage is higher than 3V, the threshold for peak current limit V_{CS_TH} decreases linearly as shown in Figure 5. When the VLN pin is not used, it should be connected to a 2V reference voltage.

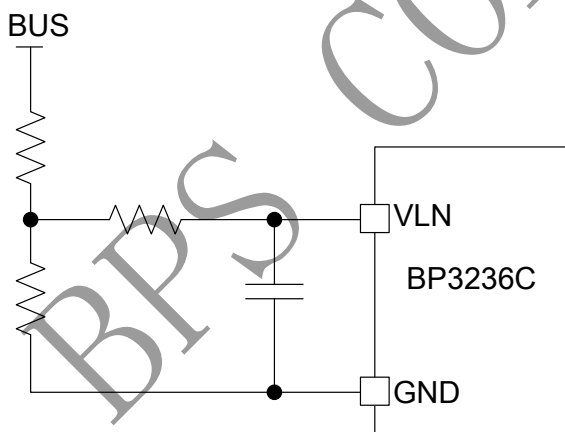

Figure 5. VLN pin buck-boost application circuit

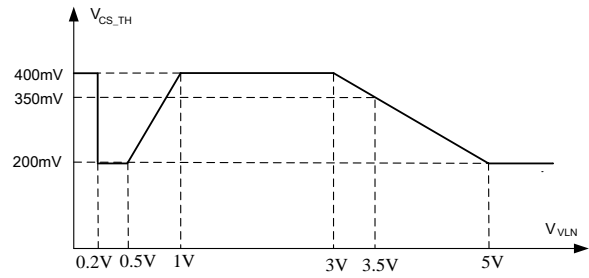

Figure 6. Relationship of VLN voltage and V_{CS_TH}

Inductor Selection

The BP3236C works under inductor current critical conduction mode. When the power MOSFET is switched on, the current in the inductor rises up from zero, the buck-boost on time of the MOSFET can be calculated by the equation:

$$t_{on} = \frac{L \times I_{PK}}{V_{IN}}$$

Where,

L is the inductance value.

V_{IN} is the DC bus voltage after the rectifier bridge.

V_{LED} is the voltage on the LED.

The maximum on time of the MOSFET is set to 10us internally.

After the power MOSFET is switched off, the current in the inductor decreases. When the inductor current reaches zero, the power MOSFET is turned on again by IC internal logic. The buck-boost off time of the MOSFET is given by:

$$t_{off} = \frac{L \times I_{PK}}{V_{LED}}$$

The buck-boost inductance can be calculated by the equation:

$$L = \frac{V_{LED} \times V_{IN}}{f \times I_{PK} \times (V_{IN} + V_{LED})}$$

Where, f is the maximum buck-boost system switching frequency, which is proportional to the input voltage. So the minimum switching frequency is set at lowest input voltage, and the maximum switching frequency is set at highest input voltage.

Over Voltage Protection Setting

The OVP pin is used to detection the output voltage for over voltage protection (OVP). The OVP pin threshold is 1V.

The resistor divider of the OVP pin can be set as:

$$V_{OVP} = \frac{R_1 + R_2 + R_3}{R_3}$$

Where,

R₃ is the lower resistor of the resistor divider
R₁ and R₂ is the higher resistor of the resistor divider
V_{OVP} is the over voltage protection set value.

For optimizing the system efficiency, the lower resistor is recommended to be around 5KΩ.

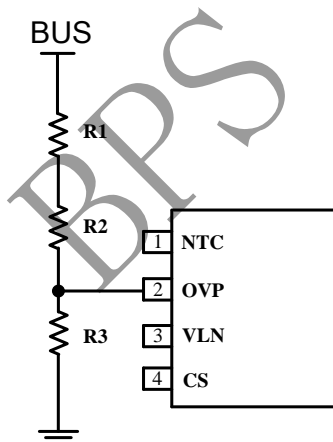

Figure 7. OVP pin buck-boost application circuit

NTC Setting

BP3236C can externally set the power reducing point by connect a NTC resistor to NTC pin to achieve an accurate system operating temperature. NTC pin offers 50uA source current for external NTC resistor, when environment temperature rises, NTC resistance reducing rapidly, when the NTC pin voltage is less than 500mV, IC start to reduce the CS pin reference voltage V_{CS_TH}, to achieve lower output power and make the environment temperature stable. The maximum decreasing amplitude of V_{CS_TH} is 25%. NTC pin can be floating if not use.

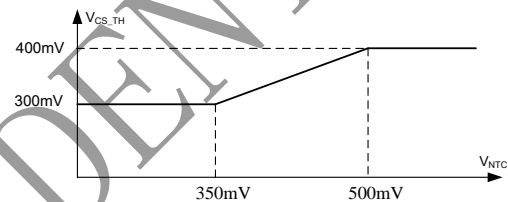

Figure 8. Relationship of NTC voltage and V_{CS_TH}

Protection Function

The BP3236C offers rich protection functions to improve the system reliability, including LED open/short protection, V_{CC} under voltage protection, thermal regulation.

When the LED is open circuit, the system will trigger the over voltage protection and stop switching.

When the LED short circuit is detected, the system works at low frequency (5kHz), and the CS pin turn off threshold is reduced to 200mV. So the system power consumption is very low. At some catastrophic fault condition, such as output shorted or inductor saturated, the internal fast fault detection circuit will be triggered, the system stops switching immediately.



After the system enters into fault condition, the VCC voltage will decrease until it reaches the UVLO threshold, then the system will re-start again. If the fault condition is removed, the system will recover to normal operation.

Thermal Regulation

The BP3236C integrates thermal regulation function. When the system is over temperature, the output current is gradually reduced; the output power and thermal dissipation are also reduced. The system temperature is regulated and the system reliability is improved. The thermal regulation temperature is set to 150°C internally.

PCB Layout

The following rules should be followed in BP3236C PCB layout:

Bypass Capacitor

The bypass capacitor on VCC pin should be as close as possible to the VCC Pin and GND pin.

OVP Pin

The feedback resistor divider should be as close as possible to the OVP pin, and the trace must keep away from dynamic node of the inductor and Drain pin trace, otherwise the OVP pin OVP function might have risk to be mis-triggered by the system noise.

VLN Pin

The VLN pin resistor divider and capacitor should be as close as possible to the VLN pin, and the VLN node should be away from the high voltage switching nodes.

NTC Pin

The NTC pin resistor divider and capacitor should be close to the NTC pin, and the NTC node should be away from the high voltage switching nodes.

Ground Path

The power ground path for current sense resistor should be short and wide, and it should be as close as possible to the IC GND pin. The IC signal ground for OVP resistors should be connected to the IC GND pin with short traces, and should be away from the power ground path.

The Area of Power Loop

The area of main current loop should be as small as possible to reduce EMI radiation, such as the power MOSFET, the output diode and the bus capacitor loop.

DRAIN Pin

To increase the copper area of DRAIN pin for better thermal dissipation. However, too large copper area may compromise the EMI performance.

Physical Dimensions

