

NACL.1000B-S5/SP4N 电流传感器 Current Transducer

版本: A

产品说明

Applications

该磁平衡式霍尔电流传感器适用于对交流、直流和脉动电流的隔离精确测量，测量时一次侧与二次侧之间完全绝缘。

For the electronic measurement of currents: AC, DC IMPL.,etc.,with galvanic isolation between the primary (high power) and the secondary (electronic) circuits.



产品优点 Advantages	产品应用 Applications	参照标准 Standards
高精度 Excellent accuracy	交流变频器 AC variable speed drives	EN50178
线性度好 Very good linearity	伺服电机驱动 Servo motor drives	EN50155
低温漂 Low temperature drift	电池供电 Battery supplied applications	
宽频带 Wide frequency bandwidth	变流器/逆变器 converter /inverter	
快速响应 Optimized response time	UPS/SVG	

主要电气参数 Main electrical data				
额定测量电流 I_{PN} (A)	Primary nominal current rms		1000	
测量范围 I_P (A)	Primary current measuring range		0~±3000	
匝比	Conversion ratio		1:5000	
电源电压 V_C (V)	Supply voltage		DC±(15~24)×(1±10%)V	
额定测量输出 I_{SN} (mA)	Secondary nominal current rms		200mA	
测量电阻 R_M (Ω)	Measuring resistance			
	70°C		85°C	
	R_{Mmin}	R_{Mmax}	R_{Mmin}	R_{Mmax}
with ±15V @±1000A max:	0Ω	16Ω	0Ω	13Ω
@±1500A max:	0Ω	3Ω		
with ±24V @±1000A max:	0Ω	57Ω	10Ω	54Ω
@±3000A max:	0Ω	2.5Ω		
二次侧电流消耗 I_c (@±24V)	Current consumption		≤30mA+ Secondary output current I_{SN}	
隔离耐压	Isolation test: Between the primary circuit to the secondary circuit		3.8kVrms/50Hz/1min	

精度 - 动态参数 Accuracy - Dynamic performance data

基本误差 δ_i (@ I_{PN} , $T_A=25^\circ\text{C}$)	Overall Accuracy	$\leq \pm 0.4\%$
线性度误差 δ_L (@ I_{PN} , $T_A=25^\circ\text{C}$)	Linearity error	$< 0.1\%$
零点输出电流 I_0 (@ $I_P=0$, $T_A=25^\circ\text{C}$)	Offset current	$\leq \pm 0.4\text{mA}$
零点温漂 I_{OT}	Thermal drift	$\leq \pm 0.8\text{mA} (-40^\circ\text{C} \sim +85^\circ\text{C})$
响应时间 t_r (@ $di/dt=100\text{A/us}$, 90% IPN)	Response time to 90% of I_{PN} step	$\leq 1\mu\text{s}$
频率带宽 BW	Frequency bandwidth(-1dB)	DC..100kHz

一般数据 General data

工作温度 T_a	Ambient operating temperature	$-40^\circ\text{C} \sim +85^\circ\text{C}$
储存温度 T_s	Ambient storage temperature	$-45^\circ\text{C} \sim +90^\circ\text{C}$
电气间隙	Clearance distance d_{Cl} mm	16.8
爬电距离	Creepage distance d_{Cp} mm	17
相对漏电起痕指数	胶面 CTI	≤ 600
重量	Mass	$\leq 550\text{g}$

外形图 Dimensions (in mm)

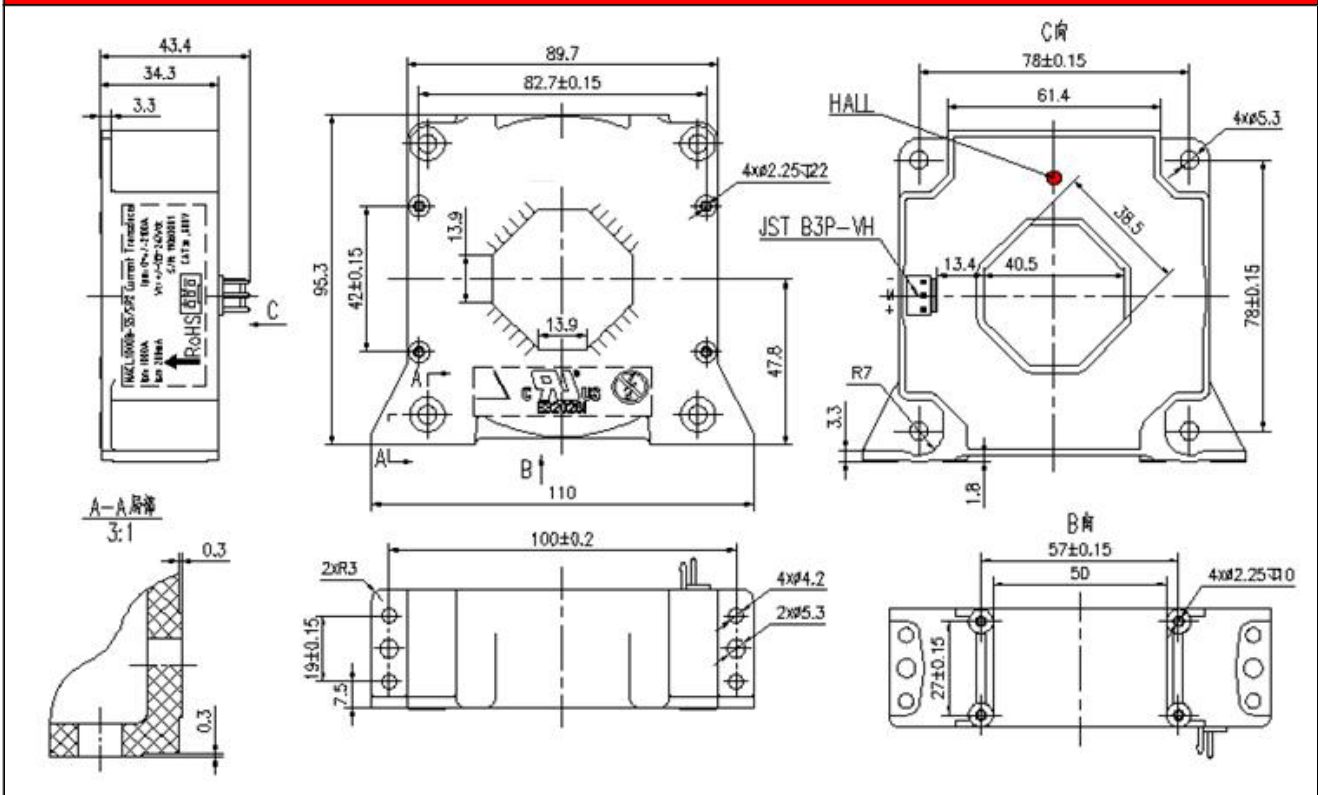

电气连接 Connection

Connection of secondary: JST B3P-VH

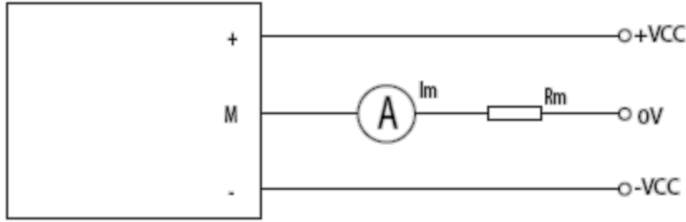

机械特征 Mechanical characteristics		备注 Remark
未注公差 General tolerance	± 1 mm	1. 当测量电流方向与传感器上标示的  方向一致时，传感器输出 I_{SN} 为正。When measuring the current direction of arrow mark on direction and sensor, the sensor output I_{SN} is positive. 2. 产品二次侧连接线优选屏蔽线，屏蔽层接近产品端连接线可接机壳，负电源或电源 0V。Product secondary side connecting line optimization shielding wire, cable shielding layer close to the product end can connect chassis, negative power or power 0 v. 3. 电量传感器安装螺钉孔的垂直度要求：要求在国家标准 8 级或以上（或 0.06 以下）。Power sensor mounting screw hole of the vertical degree requirements: requirements in the national standard grade 8 or above (or below 0.06). 4. 电量传感器安装面平面度要求：Sensor mounting surface flatness requirements: (a).大平面安装平面度国家标准 11 级或以上（或平面起伏小于 0.25mm）； Planeness national standard installation grade 11 or above (or surface fluctuation is less than 0.25 mm); (b).安装面加有小圆凸台设计时平面度要求达国家标准 12 级或以上（或平面起伏小于 0.5mm）； When mounting surface with a small round convex platform design flatness requirement of national standard grade 12 or more (or less than 0.5 mm) in plane ups and downs; 5. 未注公差±1mm: Did not note the tolerance + / - 1 mm;
传感器安装方式一(推荐) Transducer fastening (Recommended)	4 hole and 4 notch ø5.3mm 4 M5 steel screws	
传感器安装方式二(推荐) Transducer fastening (Recommended)	2 hole and 2 notches ø 5.3mm 2 M5 steel screws	
推荐力矩 Recommended fastening torque	3.5 N · m	
母排尺寸(推荐) Bus bar (Recommended)	40.5 × 13mm	
次边电气连接 Connection of secondary	JST B3P-VH	