



SPECIFICATION FOR APPROVAL

CUSTOMER: Platan

EVERCOOL MODEL NO: EC6010H12BA

CUSTOMER MODEL NO: EC6010H12BA

DESCRIPTION: DC12V FAN

APPROVED BY (AUTHORISED)	APPROVED
	Alex
	CHECKED
	Xiongwei
	DRAWN
	Chenjie
	SALES
	Serene

* Please confirm your acceptance by return fax or mail.

SPEC NO	ISSUE DATE	EDITION	REVISED DATE
20231215A17	2023/12/15	A0	2023/12/15

THE PRODUCTION ACCORD WITH EUROPE UNION ROHS STANDARD

EVERCOOL THERMAL CO., LTD

NO. 123-8, HSING DE RD., SAN-CHUNG CITY,

TAIPEI HSIEN, TAIWAN, R.O.C.

TEL: 886-2-8512-2889 FAX: 886-2-8512-2890

[URL:www.evercool.com.tw](http://www.evercool.com.tw)

[EMAIL: coolest@ms14.hinet.net](mailto:coolest@ms14.hinet.net)

I. GENERAL SPECIFICATION

Item	Specification
1.Part NO.	EC6010H12BA
2.Outline Dimension	60*60*10
3.Rated Voltage	12 VDC
4.Starting Voltage	7 VDC
5.Operating Voltage Range	7 VDC~ 13.8 VDC
6.Rated Current*	0.2 A
7.Rated Power Consumption*	2.4 W
8.Rated Speed*	4400 RPM±15%
9.Max. Airflow**	17.7 CFM(ft3/min)
10.Max. Static Pressure**	0.12 In-H2O
11.Noise Level***	<33 dB(A)
12.Life Expectancy	50000 hrs at 25°C
13.No of Polarity	4 Poles
14.Direction of Rotation	Counter-Clockwise

Noted:

***Input Current Speed Power Consumption**

Measured after continuous 30 minutes operation at rated voltage in free air at ambient temperature of 25 °C , 65% relative humidity

****Performance**

Measured with use of double chamber. The value are recorded when the fan speed is stabilized at rated voltage.

*****Noise Level**

Measured at rated voltage in a semi-anechoic chamber with background noise below than 20 dB(A). The measuring distance is in one meter from microphone to inlet of the fan.

II. ELECTRICAL SPECIFICATION

Item		Specification
1.Polarity Protection	✓ YES	Be capable of endurance when Vcc & GRD are exchanged
	NO	
2.Auto restart	YES	Locked motor protection
	✓ NO	
3.Insulation Resistance		10MΩ/b/w unshielded wire and frame at 500 VDC/min
4.Dielectric Strength		5Ma Max./Measured b/w lead wire and frame at 500VAC/min

III. MAIN MATERIALS / PARTS SPECIFICATION

Item		Specification				
1.Materials of Frame		Thermoplastic PBT of UL 94V-0(BK)				
2.Materials of Fan Blade						
3.Bobbin						
4.Bearing		Uni ball bearing				
	✓	Dual ball bearing				
		Sleeve bearing				
		EL bearing				
5.Lead wire	✓	Red (+)	UL#	1007	26	AWG
	✓	Black (-)	UL#	1007	26	AWG
	✓	Blue(FG)	UL#	1007	26	AWG

6.Connector		2510 3P				

IV. ENVIRONMENT SPECIFICATION

Item	Specification
1.Operation Temperature	-10°C ~+70°C/66%(RH), high / low temperature test for 24 hours, temperature change: 30°C /hours.
2.Storage Temperature	-40°C ~+70°C/66%(RH), high / low temperature test for 24 hours, temperature change: 30°C /hours.

V. DROPPING TEST

Prepared in minimum packing condition, fan will withstand one drop each on three surfaces from 30 cm height onto a 10mm thick hard wooden board.

VI. LABEL MARKING



VII. OUTLINE DIMENSION

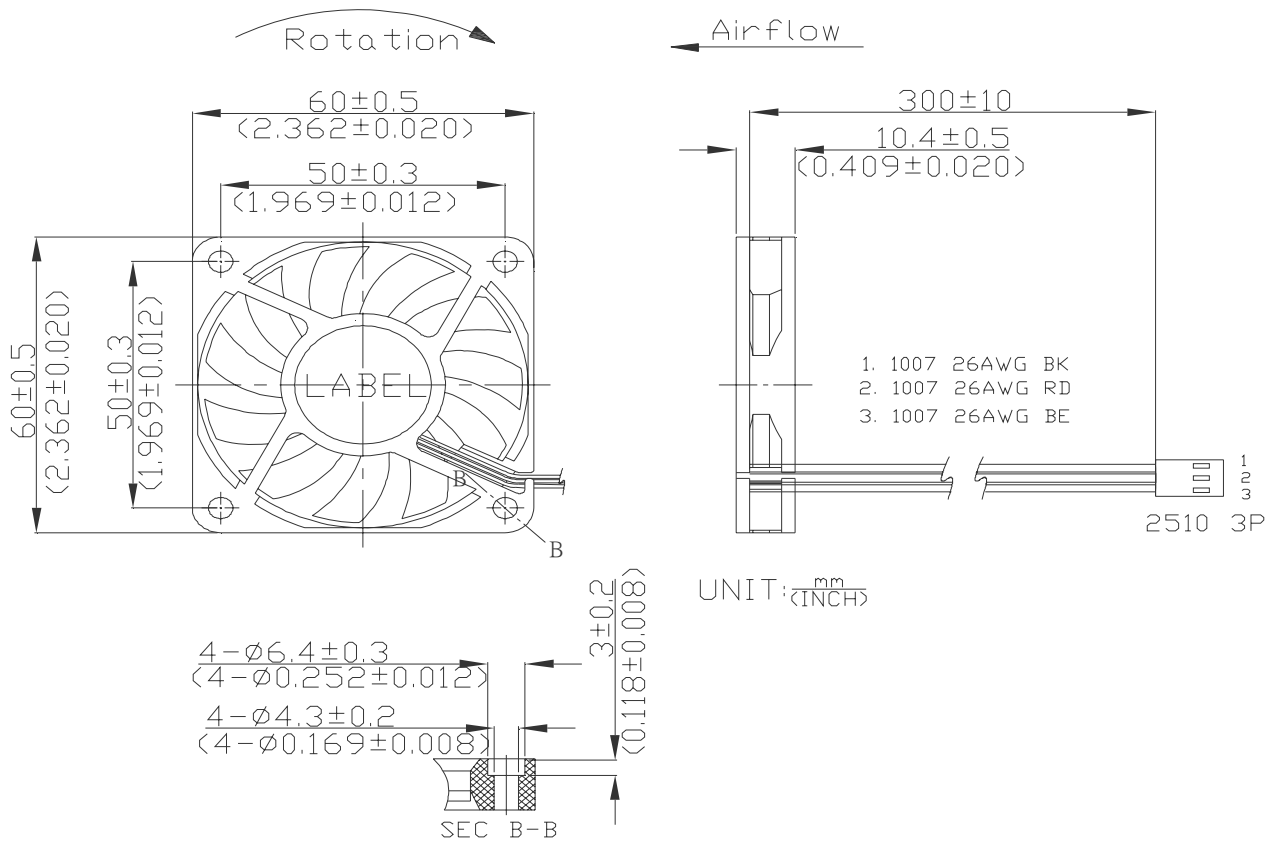

VIII. Sensor Circuit System

Speed Sensor / Tachometer (FG/F)

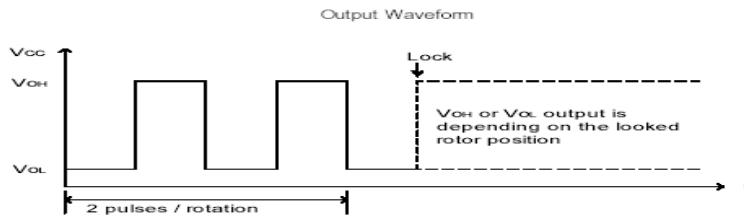
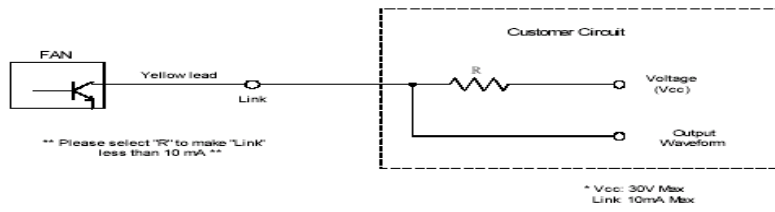

IX. P/Q Performance

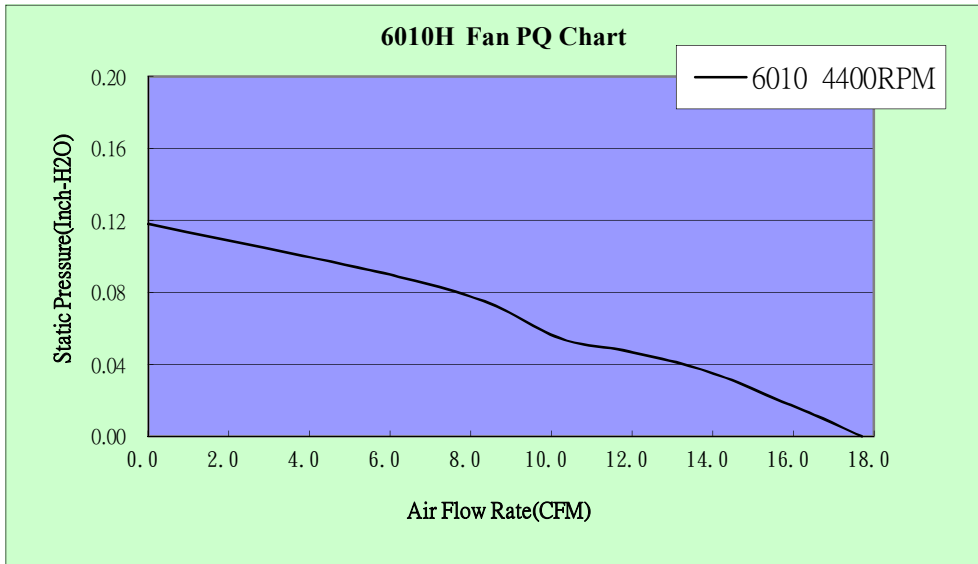

	Q(cfm)	Ps(InchH2o)
1	0.000	0.118
2	5.756	0.091
3	8.342	0.075
4	10.183	0.055
5	11.650	0.048
6	13.095	0.041
7	14.320	0.033
8	15.570	0.021
9	16.522	0.012
10	17.701	0.000