



## SPECIFICATION FOR APPROVAL

CUSTOMER: Platan

EVERCOOL MODEL NO: EC8025H12S

CUSTOMER MODEL NO: EC8025H12S

DESCRIPTION: DC12V FAN

<b>APPROVED BY (AUTHORISED)</b>	<b>APPROVED</b>
	<b>Alex</b>
	<b>CHECKED</b>
	<b>Xiongwei</b>
	<b>DRAWN</b>
	<b>Chenjie</b>
	<b>SALES</b>
	<b>Serene</b>

\* Please confirm your acceptance by return fax or mail.

SPEC NO	ISSUE DATE	EDITION	REVISED DATE
20211028A08	2020/8/24	A1	2021/10/28

THE PRODUCTION ACCORD WITH EUROPE UNION ROHS STANDARD

### EVERCOOL THERMAL CO., LTD

NO. 123-8, HSING DE RD., SAN-CHUNG CITY,  
TAIPEI HSIEN, TAIWAN, R.O.C.

TEL: 886-2-8512-2889 FAX: 886-2-8512-2890

[URL:www.evercool.com.tw](http://www.evercool.com.tw)

[EMAIL: coolest@ms14.hinet.net](mailto:coolest@ms14.hinet.net)

# I. GENERAL SPECIFICATION

Item	Specification
1.Part NO.	EC8025H12S
2.Outline Dimension	80*80*25
3.Rated Voltage	12 VDC
4.Starting Voltage	7 VDC
5.Operating Voltage Range	7 VDC~ 13.8 VDC
6.Rated Current*	0.16 A
7.Rated Power Consumption*	1.92 W
8.Rated Speed*	3000 RPM±15%
9.Max. Airflow**	36.48 CFM(ft3/min)
10.Max. Static Pressure**	0.14 In-H2O
11.Noise Level***	<33 dB(A)
12.Life Expectancy	25000 hrs at 25°C
13.No of Polarity	4 Poles
14.Direction of Rotation	Counter-Clockwise

**Noted:**

**\*Input Current Speed Power Consumption**

Measured after continuous 30 minutes operation at rated voltage in free air at ambient temperature of 25 °C, 65% relative humidity

**\*\*Performance**

Measured with use of double chamber. The value are recorded when the fan speed is stabilized at rated voltage.

**\*\*\*Noise Level**

Measured at rated voltage in a semi-anechoic chamber with background noise below than 20 dB(A). The measuring distance is in one meter from microphone to inlet of the fan.

## II. ELECTRICAL SPECIFICATION

Item		Specification
1.Polarity Protection	✓ YES	Be capable of endurance when Vcc & GRD are exchanged
	NO	
2.Auto restart	YES	Locked motor protection
	✓ NO	
3.Insulation Resistance		10MΩ/b/w unshielded wire and frame at 500 VDC/min
4.Dielectric Strength		5Ma Max./Measured b/w lead wire and frame at 500VAC/min

## III. MAIN MATERIALS / PARTS SPECIFICATION

Item		Specification				
1.Materials of Frame		Thermoplastic PBT of UL 94V-0(BK)				
2.Materials of Fan Blade						
3.Bobbin						
4.Bearing		Dual ball bearing				
		1 ball & 1 sleeve bearing				
	✓	Sleeve bearing				
		EL bearing				
5.Lead wire	✓	Red (+)	UL#	1007	26	AWG
	✓	Black (-)	UL#	1007	26	AWG
				---		
					---	
6.Connector		Nopin 2P				

## IV. ENVIRONMENT SPECIFICATION

Item	Specification
1.Operation Temperature	-10°C~+70°C/66%(RH), high / low temperature test for 24 hours, temperature change: 30°C /hours.
2.Storage Temperature	-40°C~+70°C/66%(RH), high / low temperature test for 24 hours, temperature change: 30°C /hours.

## V. DROPPING TEST

Prepared in minimum packing condition, fan will withstand one drop each on three surfaces from 30 cm height onto a 10mm thick hard wooden board.

## VI. LABEL MARKING



## VII. OUTLINE DIMENSION

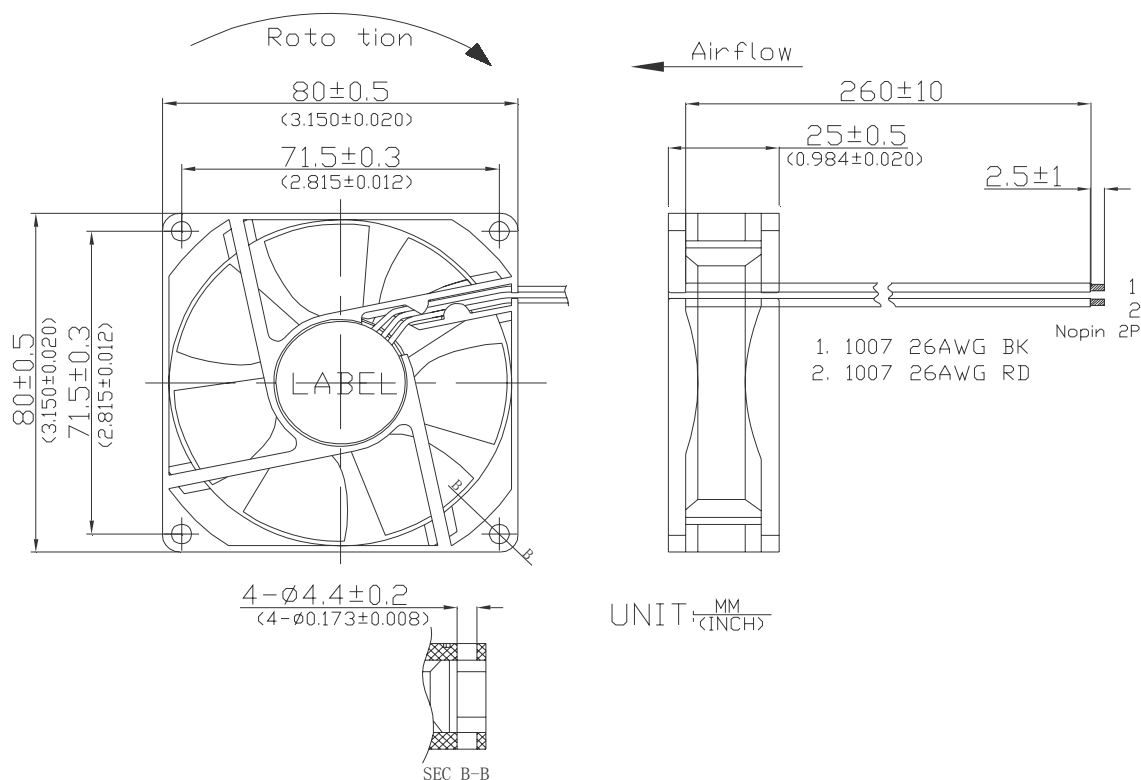

## VIII. P/Q Performance

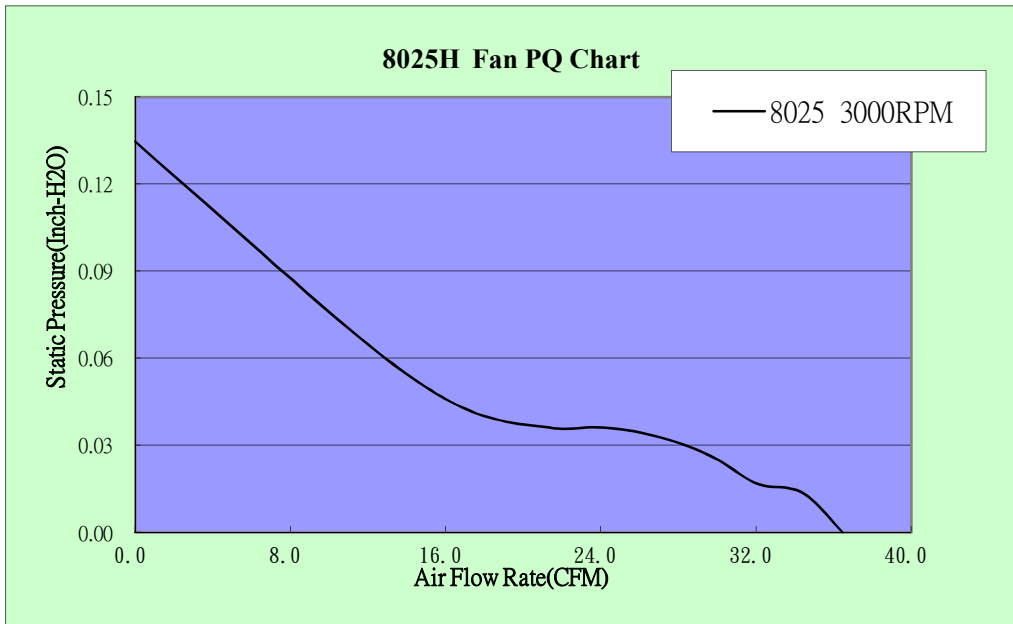

	Q(cfm)	Ps(InchH2o)
1	0.000	0.135
2	12.082	0.064
3	17.035	0.043
4	21.348	0.036
5	24.271	0.036
6	27.167	0.033
7	29.820	0.026
8	32.006	0.017
9	34.410	0.014
10	36.480	0.000