

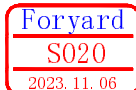

# PRODUCT SPECIFICATION

**Model No.: FYD-5621EUG-21-L4.0**

Descriptions:
<ul style="list-style-type: none"> <li>■ 0.56 Inch Double Digits Display</li> <li>■ Common Cathode</li> <li>■ Emitting Color : Ultra Yellow Green</li> <li>■ Chip Material:AlGaInP</li> <li>■ Gray Face</li> <li>■ White Segment</li> </ul>



CUSTOMER APPROVED SIGNATURES	APPROVED BY	SALES BY	PREPARED BY
			

**NINGBO FORYARD OPTOELECTRONICS CO.,LTD**

**Add:**NO.666 Jinghua Road, Hi-tech Park, Ningbo, Zhejiang, China

**Zip:**315103

**Tel:** 0086-574-87933652 87927870 87922206

**Fax:** 0086-574-87927917

**E-mail:**Sales@foryard.com ( General)

**Http://www.foryard.com**

**Model No.: FYD-5621EUG-21-L4.0**

**■ Features -**

1. 0.56 inch (14.20mm) digit height.
2. Case mold type.
3. RoHS compliant.
4. Low current operation
5. Low power consumption.
6. Easy mounting on P.C. board or socket.

**■ Mechanical Dimensions -**

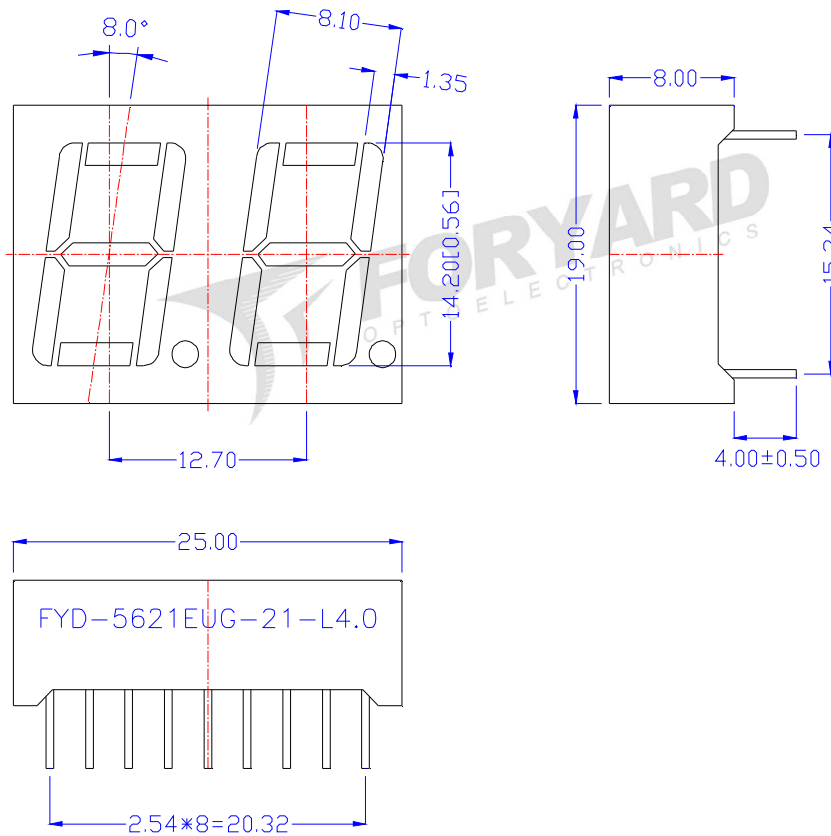

**Notes:**

1. All pins are  $\Phi 0.51 [0.020]$ mm
2. Dimension in millimeter [inch], tolerance is  $\pm 0.25 [0.010]$  and angle is  $\pm 1^\circ$  unless otherwise noted.
3. Bending  $\leq$  Length \* 1%.
4. The specifications, characteristics and technical data described in the datasheet are subject to change without prior notice.

Model No.: FYD-5621EUG-21-L4.0

■ All Light On Segments Feature & Pin Position

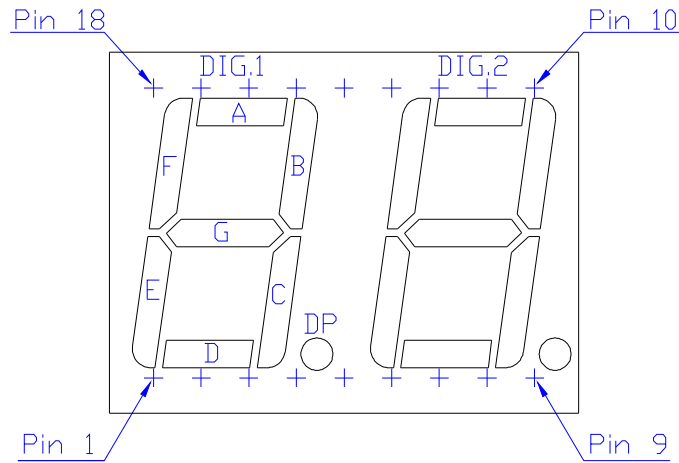

■ Internal Circuit Diagrams -

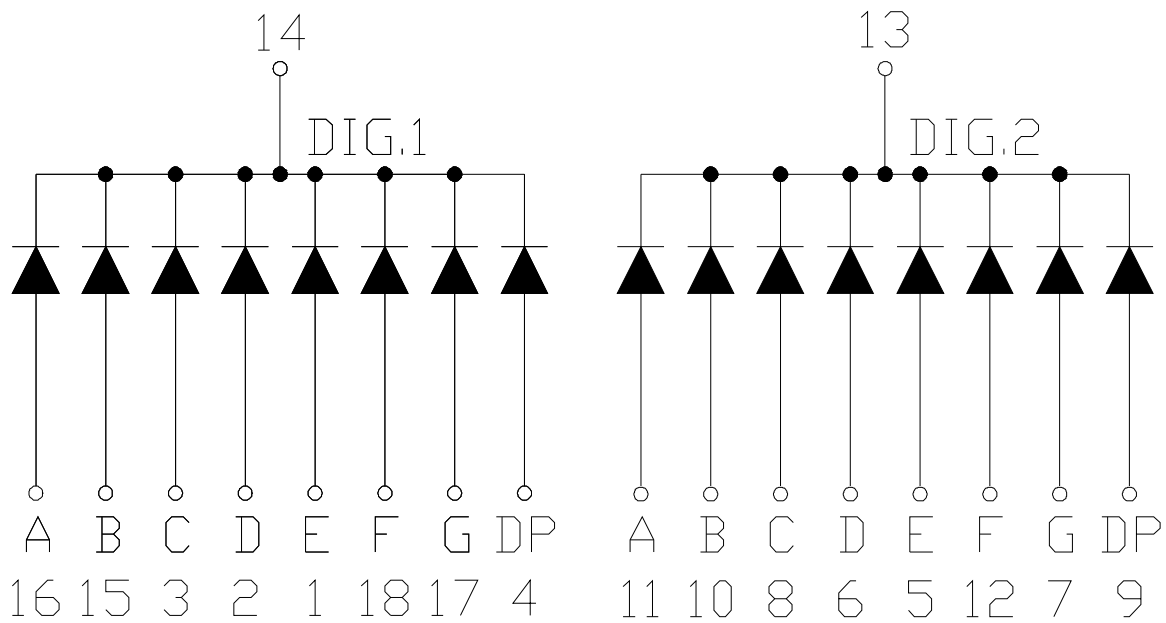

**Model No.: FYD-5621EUG-21-L4.0**

■ **Absolute maximum ratings**

(Ta=25°C)

Parameter	Symbol	Test Condition	Value		Unit
			Min	Max	
Reverse Voltage	VR	IR=30	5	—	V
Forward Current	IF	—	—	30	mA
Power Dissipation	Pd	—	—	75	mW
Pulse Current	Ipeak	Duty=0.1mS,1KHz	—	150	mA
Operating Temperature	Topr	—	-40	+85	°C
Storage Temperature	Tstr	—	-40	+85	°C

■ **Electrical-Optical Characteristics**

● **Color Code & Chip Characteristics:(Test Condition:IF=10mA)**

(Ta=25°C)

Emitting Color		Dice Material	Peak Wave Length( $\lambda_p$ )	Spectral Line halfwidth h( $\Delta\lambda$ )	Forward Voltage(VF) Unit:V		Luminous Intensity (Iv) Unit:mcd
					Typ	Max	
UHR	Ultra Hi Red	AlGaInP	640nm	20nm	2.00	2.50	20~50
Segment-to-Segment Luminous Intensity ratio(Iv-M)						1.5:1	

Note:

- 1.Luminous Intensity is based on the Foryard standards.
- 2.Pay attention about static for InGaN

**Model No.: FYD-5621EUG-21-L4.0**

**Typical Electrical / Optical Characteristics Curves**

(Ta = 25°C Unless Otherwise Noted)

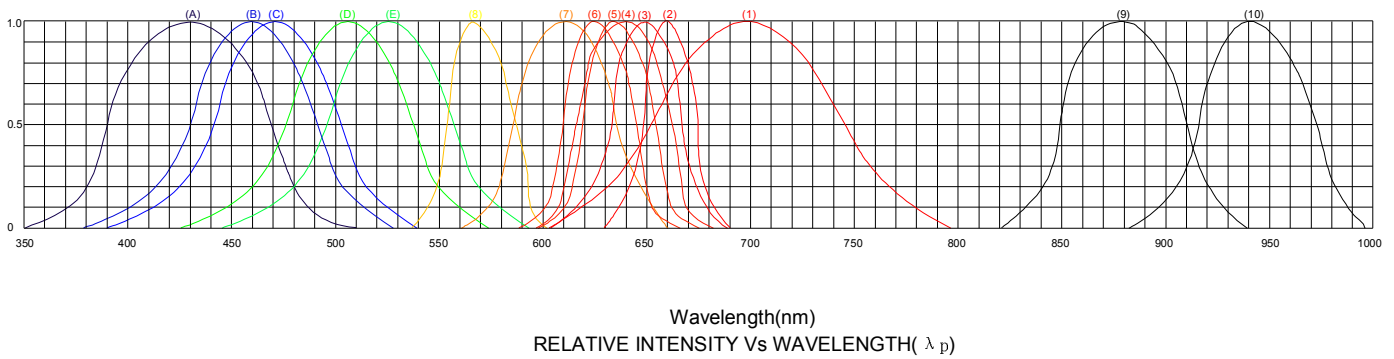

- (1)-GaP 700nm/Red
- (2)-AlGaAs/SH 660nm/Hi Red
- (3)-AlGaAs/DH 650nm/Super Red
- (4)-AlGaInP/640nm/Ultra Hi Red
- (5)-AlGaInP/635nm/Ultra Red
- (6)-GaAlP/AlGaInP/625nm/Orange
- (7)-GaAsP/AlGaInP 610nm/Amber
- (8)-GaP 570nm/Yellow Green
- (9)-GaAlAs 880nm
- (10)-GaAs/GaAs & GaAlAs/GaAs 940nm
- (A)-GaN/SiC 430nm/Blue
- (B)-InGaN/SiC 460nm/Blue
- (C)-InGaN/SiC 470nm/Blue
- (D)-InGaN/SiC 505nm/Ultra Green
- (E)-InGaN/SiC 525nm/Ultra Green

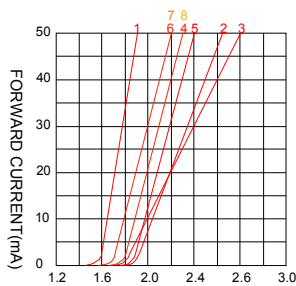

**FORWARD VOLTAGE(Vf)**  
FORWARD CURRENT VS.  
FORWARD VOLTAGE

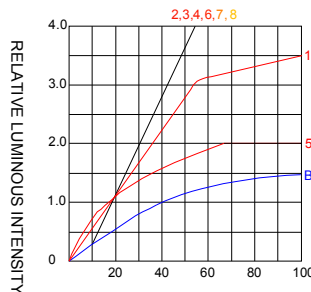

**FORWARD CURRENT (mA)**  
RELATIVE LUMINOUS  
INTENSITY VS FORWARD  
CURRENT

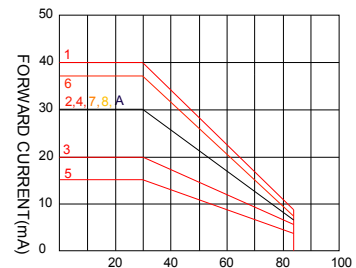

**AMBIENT TEMPERATURE Ta(°C)**  
FORWARD CURRENT VS. AMBIENT  
TEMPERATURE

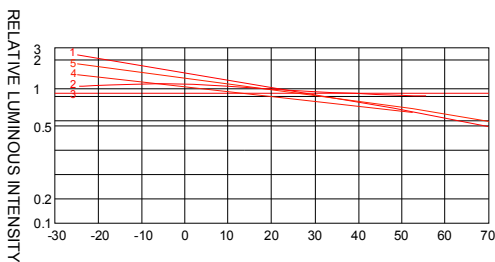

**AMBIENT TEMPERATURE  
Ta(°C)**

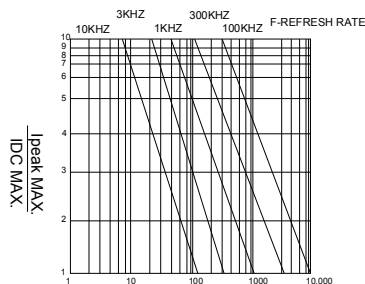

**tp-PULSE DURATION μs**  
(1,2,3,4,6,8,B,D,J,K)

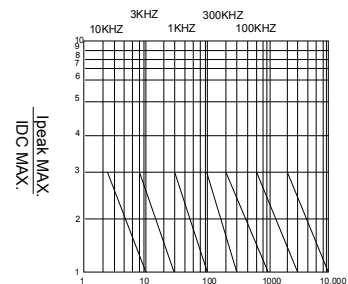

**tp-PULSE DURATION μs**  
(5)

NOTE: 25°C free air temperature unless otherwise specified

**Model No.: FYD-5621EUG-21-L4.0**

**■ Precautions For Use -**

**1. Recommended Soldering conditions-Wave Soldering**

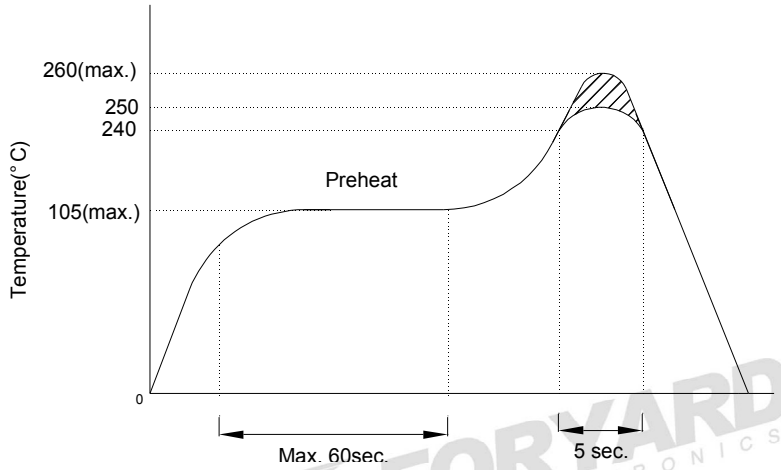

**2. Soldering Iron**

Basic SPEC. is  $\leq 5$ sec. When  $260^{\circ}\text{C}$ . If temperature is higher, time should be shorter ( $+10^{\circ}\text{C} \rightarrow -1$ sec.).

Power dissipation of iron should be smaller than 15W, and temperature should be controllable.

Surface temperature of the device should be under  $230^{\circ}\text{C}$ .

Model No.: FYD-5621EUG-21-L4.0

■ Packing Diagram

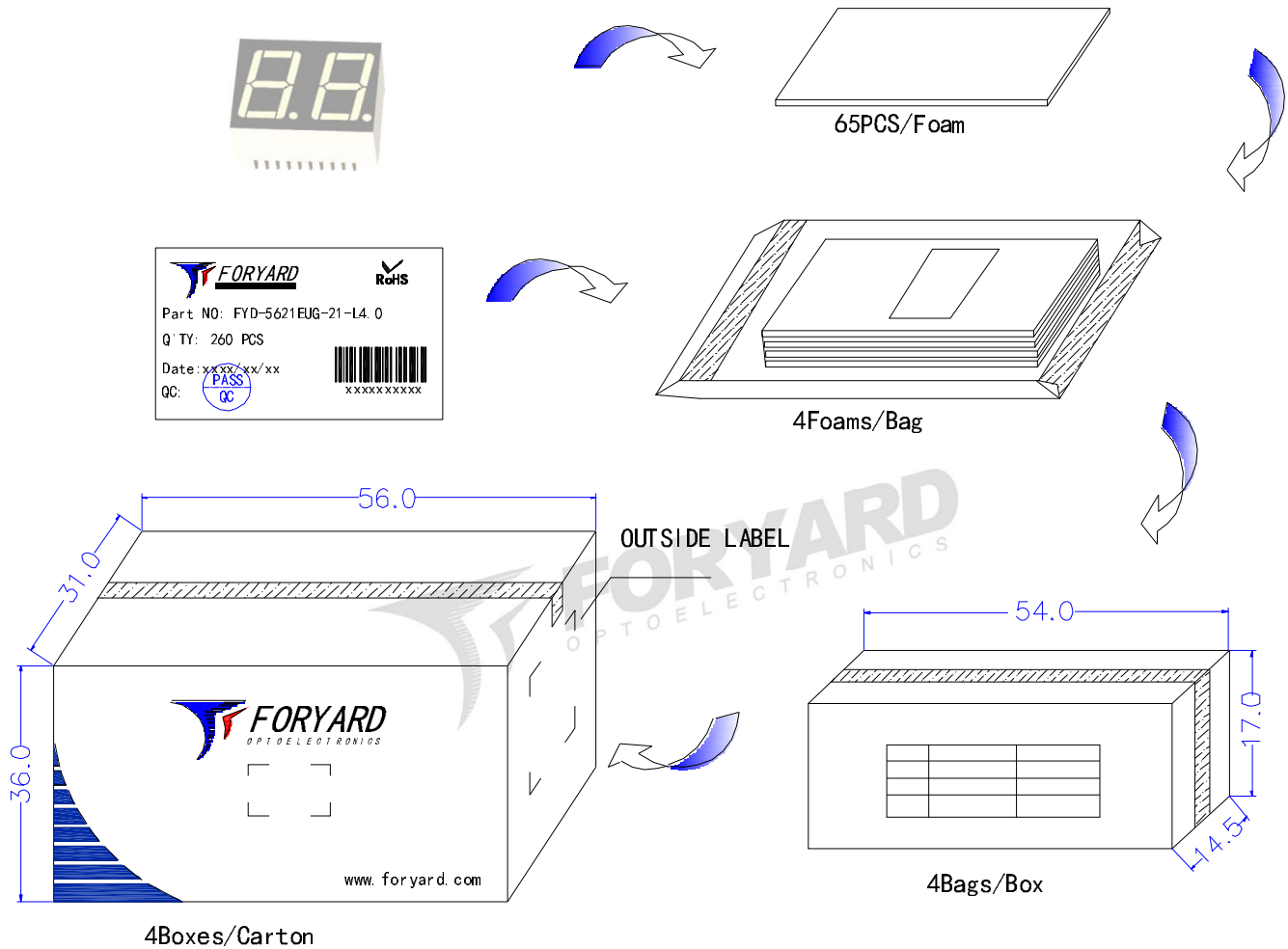

**FORYARD**  
OPTOELECTRONICS

**LED**  
PN: FYD-5621EUG-21-L4.0  
Qty: 4160 PCS  
Date: xxxx/xx/xx  
GW: 22.00KG      QC:   
NW: 20.00KG

  
XXXXXXXXXX

OUTSIDE LABEL

Note: The specifications are subject to change without notice. Please contact us for updated information.