

THREE-TERMINAL POSITIVE VOLTAGE REGULATOR

FEATURES

Maximum Output current

I_{OM} : 0.1 A

Output voltage

V_o : 12 V

Continuous total dissipation

P_D : 0.5W

SOT-89-3L

1. OUT

2. GND

3. IN

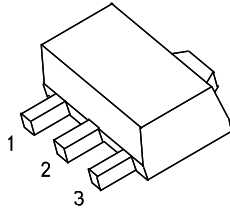

SOT-89 PACKAGE OUTLINE

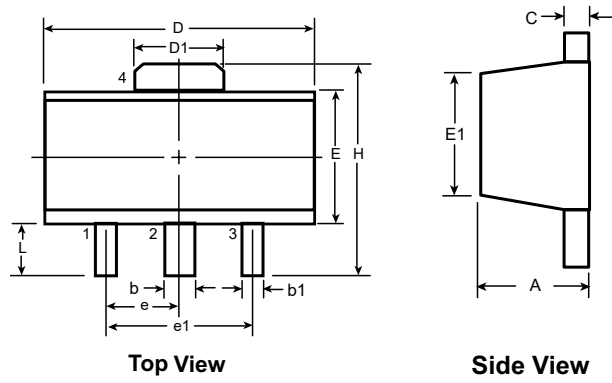

Symbol	A	b	b1	C	D	D1	E	E1	e	e1	H	L	
Dimensions (mm)	MIN	1.40	0.44	0.36	0.3	4.40	1.50	2.29	2.00 ^r	1.50	3.00	3.94	0.89
	NOM	-	-	-	-	-	-	-	-	BSC	BSC	-	-
	MAX	1.60	0.56	0.48	0.5	4.60	1.75	2.60	2.29	-	-	4.25	1.20

Dimensions in mm

ABSOLUTE MAXIMUM RATINGS (Operating temperature range applies unless otherwise specified)

Parameter	Symbol	Value	Units
Input Voltage	V_I	35	V
Operating Junction Temperature Range	T_{OPR}	0~+150	°C
Storage Temperature Range	T_{STG}	-55~+150	°C

ELECTRICAL CHARACTERISTICS AT SPECIFIED VIRTUAL JUNCTION TEMPERATURE ($V_i=19V$, $I_o=40mA$, $C_i=0.33\mu F$, $C_o=0.1\mu F$, unless otherwise specified)

Parameter	Symbol	Test conditions	MIN	TYP	MAX	UNIT	
Output voltage	V_o	$25^\circ C$	11.5	12	12.5	V	
		0-125 $^\circ C$	$14V \leq V_i \leq 27V$, $I_o=1mA-40mA$	11.4	12	12.6	V
			$I_o=1mA-70mA$	11.4	12	12.6	V
Load Regulation	ΔV_o	$I_o=1mA-100mA$	$25^\circ C$	22	100	mV	
		$I_o=1mA-40mA$	$25^\circ C$	13	50	mV	
Line regulation	ΔV_o	$14.5V \leq V_i \leq 27V$	$25^\circ C$	55	250	mV	
		$16V \leq V_i \leq 27V$	$25^\circ C$	49	200	mV	
Quiescent Current	I_q	$25^\circ C$		4.3	6.5	mA	
Quiescent Current Change	ΔI_q	$16V \leq V_i \leq 27V$	0-125 $^\circ C$		1.5	mA	
	ΔI_q	$1mA \leq I_o \leq 40mA$	0-125 $^\circ C$		0.1	mA	
Output Noise Voltage	V_N	$10Hz \leq f \leq 100KHz$	$25^\circ C$	70		μV	
Ripple Rejection	RR	$15V \leq V_i \leq 25V, f=120Hz$	0-125 $^\circ C$	37	42	dB	
Dropout Voltage	V_d	$25^\circ C$		1.7		V	

TYPICAL APPLICATION

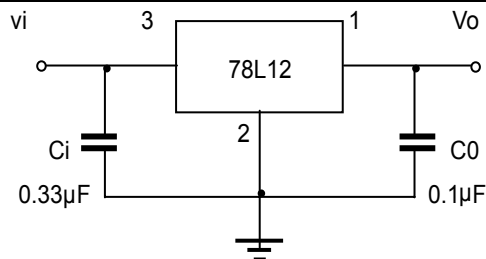

Note : Bypass capacitors are recommended for optimum stability and transient response and should be located as close as possible to the regulators.

RATING AND CHARACTERISTIC CURVES (78L12)

Output Characteristics

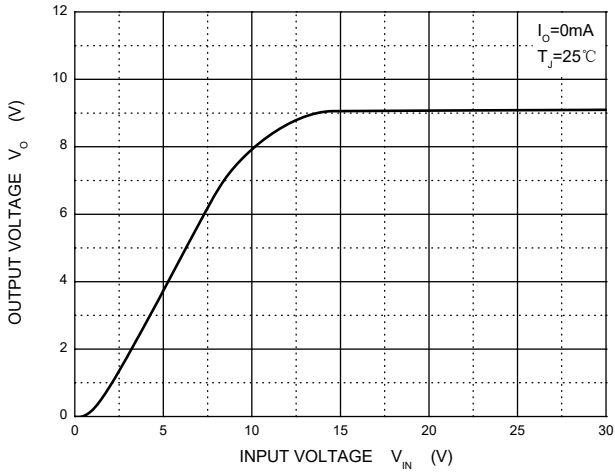

Dropout Characteristics

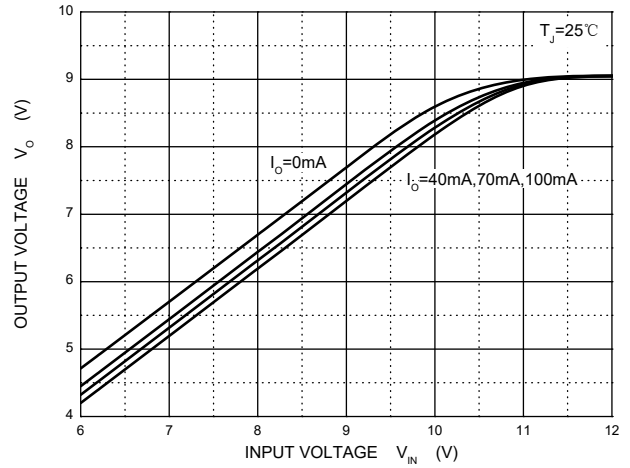

Quiescent Current vs Input Voltage

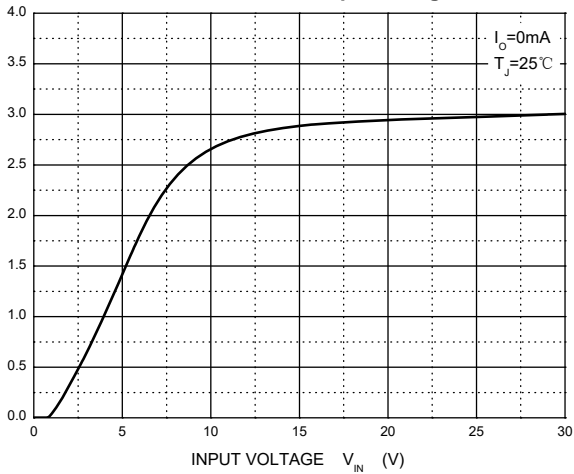

Current Cut-off Grid Voltage

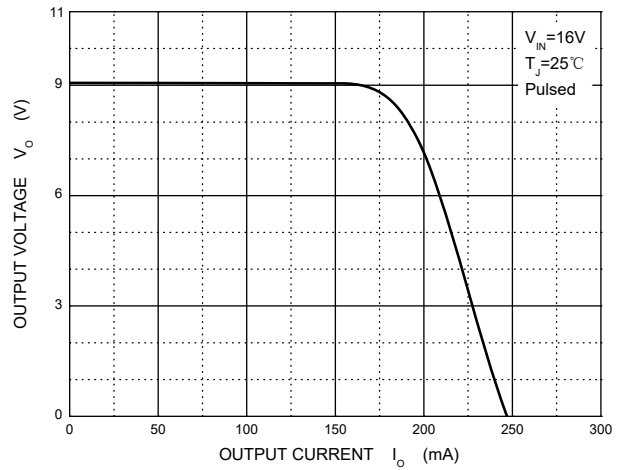

Output Voltage vs Junction Temperature

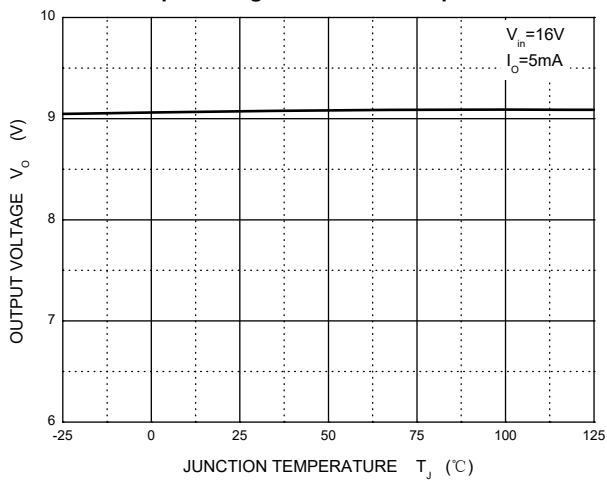

Power Derating Curve

