



## FEATURES

- High speed (up to 1 Mbaud)
- Very low ElectroMagnetic Emission (EME)
- Differential receiver with wide common-mode range for high ElectroMagnetic Immunity (EMI)
- An unpowered node does not disturb the bus lines
- Transmit Data (TXD) dominant time-out function
- Silent mode in which the transmitter is disabled
- Bus pins protected against transients in an automotive environment
- Input levels compatible with 3.3 V and 5 V devices
- Thermally protected
- Short-circuit proof to battery and to ground
- At least 110 nodes can be connected.

## GENERAL DESCRIPTION

The TJA1050 is the interface between the Controller Area Network (CAN) protocol controller and the physical bus. The device provides differential transmit capability to the bus and differential receive capability to the CAN controller.

- Much lower electromagnetic emission due to optimal matching of the output signals CANH and CANL
- Improved behaviour in case of an unpowered node
- No standby mode.

This makes the TJA1050 eminently suitable for use in nodes that are in a power-down situation in partially powered networks.

## QUICK REFERENCE DATA

SYMBOL	PARAMETER	CONDITIONS	MIN.	MAX.	UNIT
$V_{CC}$	supply voltage		4.75	5.25	V
$V_{CANH}$	DC voltage at pin CANH	$0 < V_{CC} < 5.25$ V; no time limit	-27	+40	V
$V_{CANL}$	DC voltage at pin CANL	$0 < V_{CC} < 5.25$ V; no time limit	-27	+40	V
$V_{i(dif)(bus)}$	differential bus input voltage	dominant	1.5	3	V
$t_{PD(TXD-RXD)}$	propagation delay TXD to RXD	$V_S = 0$ V; see Fig.7	-	250	ns
$T_{vj}$	virtual junction temperature		-40	+150	°C

## ORDERING INFORMATION

DEVICE	PACKAGE	PACKING	PACKING QTY
TJA1050T	SOP-8		

## BLOCK DIAGRAM

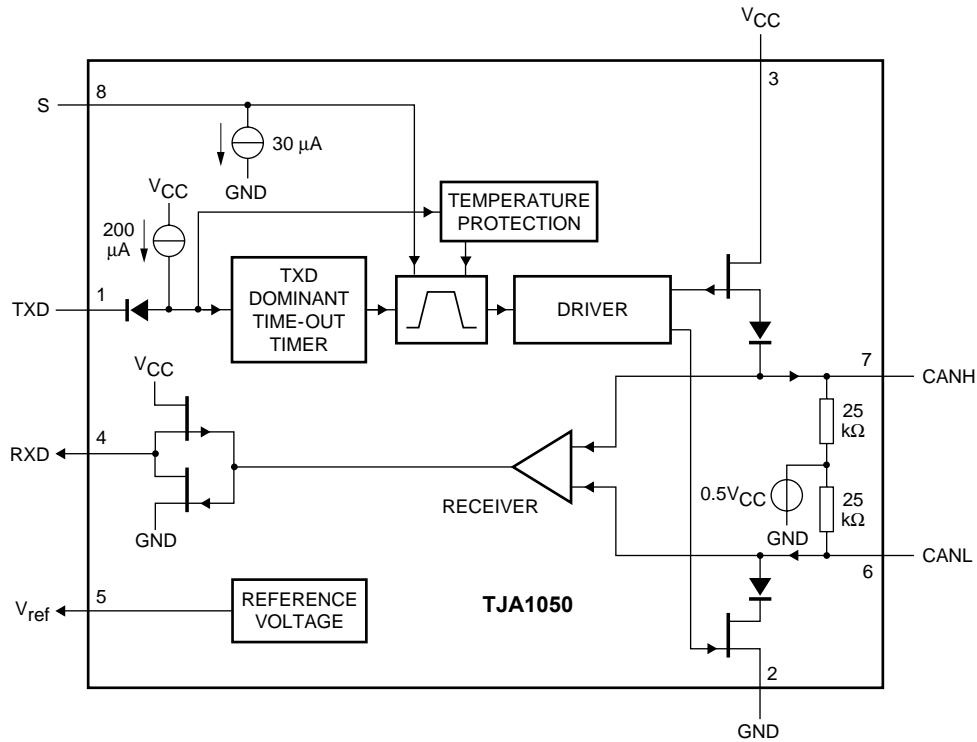

Block diagram.

## PINNING

SYMBOL	PIN	DESCRIPTION
TXD	1	transmit data input; reads in data from the CAN controller to the bus line drivers
GND	2	ground
V <sub>CC</sub>	3	supply voltage
RXD	4	receive data output; reads out data from the bus lines to the CAN controller
V <sub>ref</sub>	5	reference voltage output
CANL	6	LOW-level CAN bus line
CANH	7	HIGH-level CAN bus line
S	8	select input for high-speed mode or silent mode

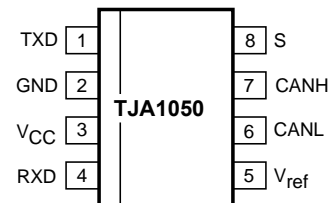

Pin configuration.



## FUNCTIONAL DESCRIPTION

The TJA1050 is the interface between the CAN protocol controller and the physical bus. It is primarily intended for high-speed automotive applications using baud rates from 60 kbaud up to 1 Mbaud. It provides differential transmit capability to the bus and differential receiver capability to the CAN protocol controller.

A current-limiting circuit protects the transmitter output stage from damage caused by accidental short-circuit to either positive or negative supply voltage, although power dissipation increases during this fault condition.

A thermal protection circuit protects the IC from damage by switching off the transmitter if the junction temperature exceeds a value of approximately 165 °C. Because the transmitter dissipates most of the power, the power dissipation and temperature of the IC is reduced. All other IC functions continue to operate. The transmitter off-state resets when pin TXD goes HIGH. The thermal protection circuit is particularly needed when a bus line short-circuits.

The pins CANH and CANL are protected from automotive electrical transients .

Control pin S allows two operating modes to be selected: high-speed mode or silent mode.

The high-speed mode is the normal operating mode and is selected by connecting pin S to ground. It is the default mode if pin S is not connected. However, to ensure EMI performance in applications using only the high-speed mode, it is recommended that pin S is connected to ground.

In the silent mode, the transmitter is disabled. All other IC functions continue to operate. The silent mode is selected by connecting pin S to V<sub>CC</sub> and can be used to prevent network communication from being blocked, due to a CAN controller which is out of control.

A 'TXD dominant time-out' timer circuit prevents the bus lines being driven to a permanent dominant state (blocking all network communication) if pin TXD is forced permanently LOW by a hardware and/or software application failure. The timer is triggered by a negative edge on pin TXD. If the duration of the LOW-level on pin TXD exceeds the internal timer value, the transmitter is disabled, driving the bus into a recessive state. The timer is reset by a positive edge on pin TXD.

**Table 1** Function table of the CAN transceiver; X = don't care

V <sub>CC</sub>	TXD	S	CANH	CANL	BUS STATE	RXD
4.75 V to 5.25 V	LOW	LOW (or floating)	HIGH	LOW	dominant	LOW
4.75 V to 5.25 V	X	HIGH	0.5V <sub>CC</sub>	0.5V <sub>CC</sub>	recessive	HIGH
4.75 V to 5.25 V	HIGH (or floating)	X	0.5V <sub>CC</sub>	0.5V <sub>CC</sub>	recessive	HIGH
<2 V (not powered)	X	X	0 V < V <sub>CANH</sub> < V <sub>CC</sub>	0 V < V <sub>CANL</sub> < V <sub>CC</sub>	recessive	X
2 V < V <sub>CC</sub> < 4.75 V	>2 V	X	0 V < V <sub>CANH</sub> < V <sub>CC</sub>	0 V < V <sub>CANL</sub> < V <sub>CC</sub>	recessive	X

**LIMITING VALUES**

In accordance with the Absolute Maximum Rating System (IEC 60134). All voltages are referenced to GND (pin 2). Positive currents flow into the IC.

SYMBOL	PARAMETER	CONDITIONS	MIN.	MAX.	UNIT
V <sub>CC</sub>	supply voltage		-0.3	+6	V
V <sub>CANH</sub>	DC voltage at pin CANH	0 < V <sub>CC</sub> < 5.25 V; no time limit	-27	+40	V
V <sub>CANL</sub>	DC voltage at pin CANL	0 < V <sub>CC</sub> < 5.25 V; no time limit	-27	+40	V
V <sub>TXD</sub>	DC voltage at pin TXD		-0.3	V <sub>CC</sub> + 0.3	V
V <sub>RXD</sub>	DC voltage at pin RXD		-0.3	V <sub>CC</sub> + 0.3	V
V <sub>ref</sub>	DC voltage at pin V <sub>ref</sub>		-0.3	V <sub>CC</sub> + 0.3	V
V <sub>S</sub>	DC voltage at pin S		-0.3	V <sub>CC</sub> + 0.3	V
V <sub>trt(CANH)</sub>	transient voltage at pin CANH	note 1	-200	+200	V
V <sub>trt(CANL)</sub>	transient voltage at pin CANL	note 1	-200	+200	V
V <sub>esd</sub>	electrostatic discharge voltage at all pins	note 2	-4000	+4000	V
		note 3	-200	+200	V
T <sub>stg</sub>	storage temperature		-55	+150	°C
T <sub>vj</sub>	virtual junction temperature	note 4	-40	+150	°C

**Notes**

- Human body model: C = 100 pF and R = 1.5 kΩ.
- Machine model: C = 200 pF, R = 10 Ω and L = 0.75 μH.
- In accordance with "IEC 60747-1". An alternative definition of T<sub>vj</sub> is: T<sub>vj</sub> = T<sub>amb</sub> + P × R<sub>th(vj-a)</sub>, where R<sub>th(vj-a)</sub> is a fixed value to be used for the calculation of T<sub>vj</sub>. The rating for T<sub>vj</sub> limits the allowable combinations of power dissipation (P) and ambient temperature (T<sub>amb</sub>).

**THERMAL CHARACTERISTICS**

According to IEC 60747-1.

SYMBOL	PARAMETER	CONDITIONS	VALUE	UNIT
R <sub>th(vj-a)</sub>	thermal resistance from junction to ambient in SO8 package	in free air	145	K/W
R <sub>th(vj-s)</sub>	thermal resistance from junction to substrate of bare die	in free air	50	K/W



# High speed CAN transceiver

TJA1050

## CHARACTERISTICS

$V_{CC} = 4.75\text{ V to }5.25\text{ V}$ ;  $T_{vj} = -40\text{ }^{\circ}\text{C to }+150\text{ }^{\circ}\text{C}$ ;  $R_L = 60\ \Omega$  unless specified otherwise; all voltages are referenced to GND (pin 2); positive currents flow into the IC; see notes 1 and 2.

SYMBOL	PARAMETER	CONDITIONS	MIN.	TYP.	MAX.	UNIT
<b>Supply (pin V<sub>CC</sub>)</b>						
I <sub>CC</sub>	supply current	dominant; V <sub>TXD</sub> = 0 V	25	50	75	mA
		recessive; V <sub>TXD</sub> = V <sub>CC</sub>	2.5	5	10	mA
<b>Transmitter data input (pin TXD)</b>						
V <sub>IH</sub>	HIGH-level input voltage	output recessive	2.0	–	V <sub>CC</sub> + 0.3	V
V <sub>IL</sub>	LOW-level input voltage	output dominant	–0.3	–	+0.8	V
I <sub>IH</sub>	HIGH-level input current	V <sub>TXD</sub> = V <sub>CC</sub>	–5	0	+5	μA
I <sub>IL</sub>	LOW-level input current	V <sub>TXD</sub> = 0 V	–100	–200	–300	μA
C <sub>i</sub>	input capacitance	not tested	–	5	10	pF
<b>Mode select input (pin S)</b>						
V <sub>IH</sub>	HIGH-level input voltage	silent mode	2.0	–	V <sub>CC</sub> + 0.3	V
V <sub>IL</sub>	LOW-level input voltage	high-speed mode	–0.3	–	+0.8	V
I <sub>IH</sub>	HIGH-level input current	V <sub>S</sub> = 2 V	20	30	50	μA
I <sub>IL</sub>	LOW-level input current	V <sub>S</sub> = 0.8 V	15	30	45	μA
<b>Receiver data output (pin RXD)</b>						
I <sub>OH</sub>	HIGH-level output current	V <sub>RXD</sub> = 0.7V <sub>CC</sub>	–2	–6	–15	mA
I <sub>OL</sub>	LOW-level output current	V <sub>RXD</sub> = 0.45 V	2	8.5	20	mA
<b>Reference voltage output (pin V<sub>ref</sub>)</b>						
V <sub>ref</sub>	reference output voltage	–50 μA < I <sub>Vref</sub> < +50 μA	0.45V <sub>CC</sub>	0.5V <sub>CC</sub>	0.55V <sub>CC</sub>	V
<b>Bus lines (pins CANH and CANL)</b>						
V <sub>o(reces)(CANH)</sub>	recessive bus voltage at pin CANH	V <sub>TXD</sub> = V <sub>CC</sub> ; no load	2.0	2.5	3.0	V
V <sub>o(reces)(CANL)</sub>	recessive bus voltage at pin CANL	V <sub>TXD</sub> = V <sub>CC</sub> ; no load	2.0	2.5	3.0	V
I <sub>o(reces)(CANH)</sub>	recessive output current at pin CANH	–27 V < V <sub>CANH</sub> < +32 V; 0 V < V <sub>CC</sub> < 5.25 V	–2.0	–	+2.5	mA
I <sub>o(reces)(CANL)</sub>	recessive output current at pin CANL	–27 V < V <sub>CANL</sub> < +32 V; 0 V < V <sub>CC</sub> < 5.25 V	–2.0	–	+2.5	mA
V <sub>o(dom)(CANH)</sub>	dominant output voltage at pin CANH	V <sub>TXD</sub> = 0 V	3.0	3.6	4.25	V
V <sub>o(dom)(CANL)</sub>	dominant output voltage at pin CANL	V <sub>TXD</sub> = 0 V	0.5	1.4	1.75	V
V <sub>i(dif)(bus)</sub>	differential bus input voltage (V <sub>CANH</sub> – V <sub>CANL</sub> )	V <sub>TXD</sub> = 0 V; dominant; 42.5 Ω < R <sub>L</sub> < 60 Ω	1.5	2.25	3.0	V
		V <sub>TXD</sub> = V <sub>CC</sub> ; recessive; no load	–50	0	+50	mV



# High speed CAN transceiver

TJA1050

SYMBOL	PARAMETER	CONDITIONS	MIN.	TYP.	MAX.	UNIT
$I_{o(sc)}(CANH)$	short-circuit output current at pin CANH	$V_{CANH} = 0\text{ V}; V_{TXD} = 0\text{ V}$	-45	-70	-95	mA
$I_{o(sc)}(CANL)$	short-circuit output current at pin CANL	$V_{CANL} = 36\text{ V}; V_{TXD} = 0\text{ V}$	45	70	100	mA
$V_{i(dif)}(th)$	differential receiver threshold voltage	$-12\text{ V} < V_{CANL} < +12\text{ V}; -12\text{ V} < V_{CANH} < +12\text{ V};$ see Fig.5	0.5	0.7	0.9	V
$V_{i(dif)}(hys)$	differential receiver input voltage hysteresis	$-12\text{ V} < V_{CANL} < +12\text{ V}; -12\text{ V} < V_{CANH} < +12\text{ V};$ see Fig.5	50	70	100	mV
$R_{i(cm)}(CANH)$	common mode input resistance at pin CANH		15	25	35	k $\Omega$
$R_{i(cm)}(CANL)$	common mode input resistance at pin CANL		15	25	35	k $\Omega$
$R_{i(cm)}(m)$	matching between pin CANH and pin CANL common mode input resistance	$V_{CANH} = V_{CANL}$	-3	0	+3	%
$R_{i(dif)}$	differential input resistance		25	50	75	k $\Omega$
$C_{i}(CANH)$	input capacitance at pin CANH	$V_{TXD} = V_{CC};$ not tested	-	7.5	20	pF
$C_{i}(CANL)$	input capacitance at pin CANL	$V_{TXD} = V_{CC};$ not tested	-	7.5	20	pF
$C_{i}(dif)$	differential input capacitance	$V_{TXD} = V_{CC};$ not tested	-	3.75	10	pF
$I_{LI}(CANH)$	input leakage current at pin CANH	$V_{CC} = 0\text{ V}; V_{CANH} = 5\text{ V}$	100	170	250	$\mu\text{A}$
$I_{LI}(CANL)$	input leakage current at pin CANL	$V_{CC} = 0\text{ V}; V_{CANL} = 5\text{ V}$	100	170	250	$\mu\text{A}$
<b>Thermal shutdown</b>						
$T_{j(sd)}$	shutdown junction temperature		155	165	180	$^{\circ}\text{C}$
<b>Timing characteristics</b> (see Figs.6 and 7)						
$t_{d}(TXD-BUSon)$	delay TXD to bus active	$V_S = 0\text{ V}$	25	55	110	ns
$t_{d}(TXD-BUSoff)$	delay TXD to bus inactive	$V_S = 0\text{ V}$	25	60	95	ns
$t_{d}(BUSon-RXD)$	delay bus active to RXD	$V_S = 0\text{ V}$	20	50	110	ns
$t_{d}(BUSoff-RXD)$	delay bus inactive to RXD	$V_S = 0\text{ V}$	45	95	155	ns
$t_{dom}(TXD)$	TXD dominant time for time-out	$V_{TXD} = 0\text{ V}$	250	450	750	$\mu\text{s}$

## Notes

- All parameters are guaranteed over the virtual junction temperature range by design, but only 100 % tested at 125  $^{\circ}\text{C}$  ambient temperature for dies on wafer level and in addition to this 100 % tested at 25  $^{\circ}\text{C}$  ambient temperature for cased products, unless specified otherwise.
- For bare die, all parameters are only guaranteed if the backside of the bare die is connected to ground.

## APPLICATION AND TEST INFORMATION

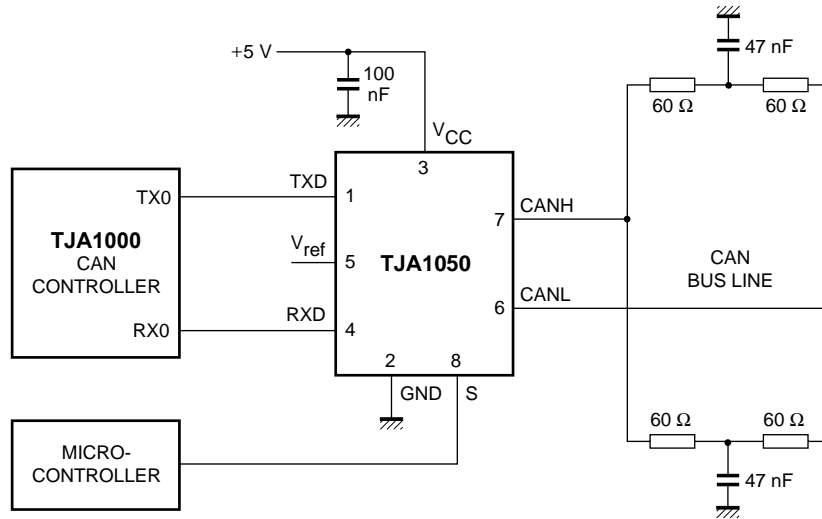

Application information.

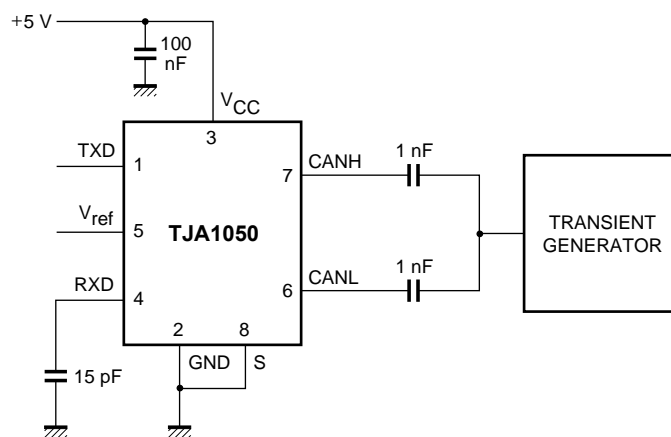

Test circuit for automotive transients.

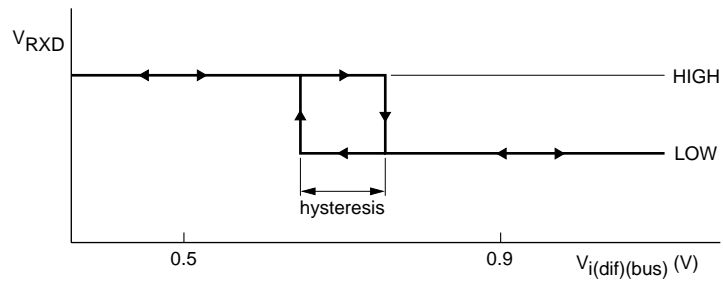

Hysteresis of the receiver.

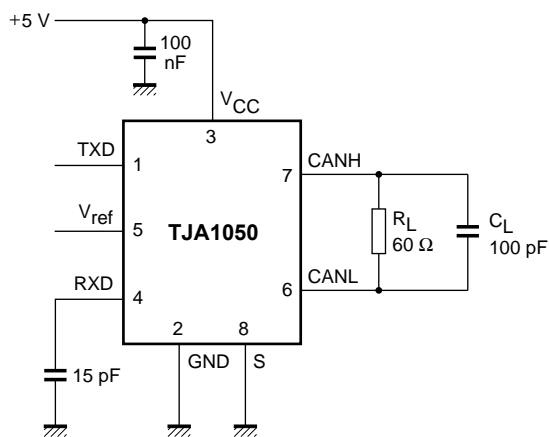

Test circuit for timing characteristics.



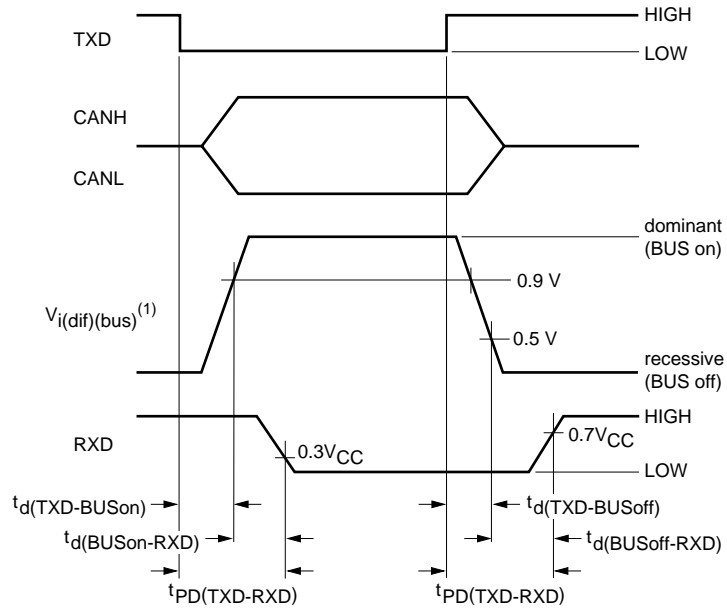

(1)  $V_{i(dif)(bus)} = V_{CANH} - V_{CANL}$ .

Timing diagram for AC characteristics.

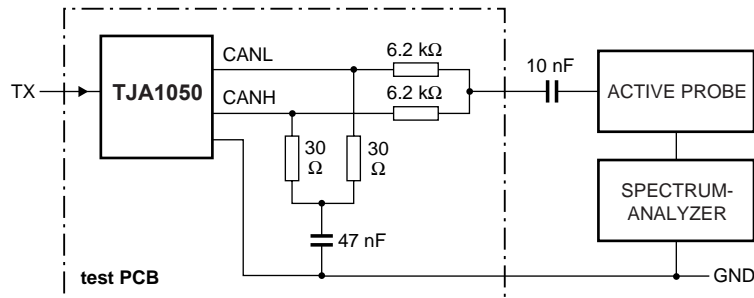

Basic test set-up (with split termination) for electromagnetic emission measurement

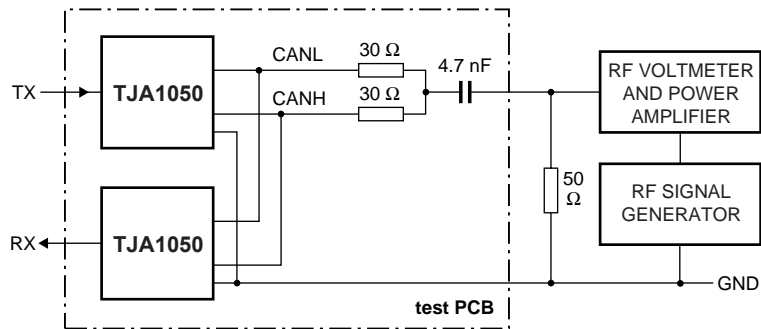

Basic test set-up for electromagnetic immunity measurement

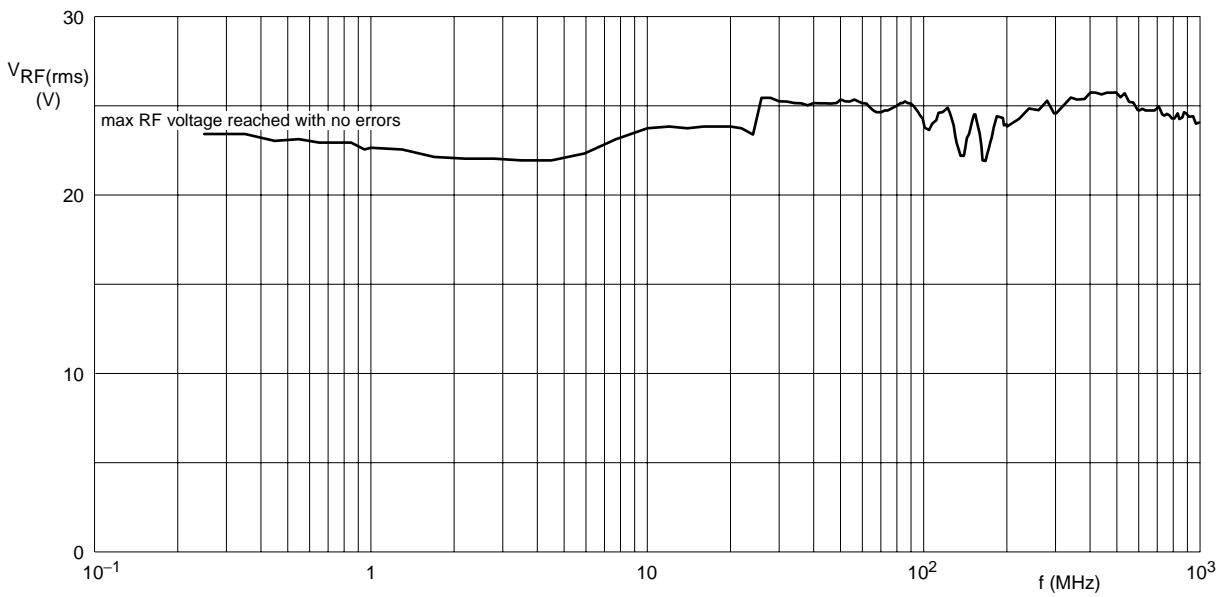

Data rate of 500 kbits/s.

Typical electromagnetic immunity.

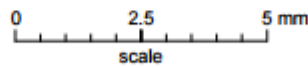
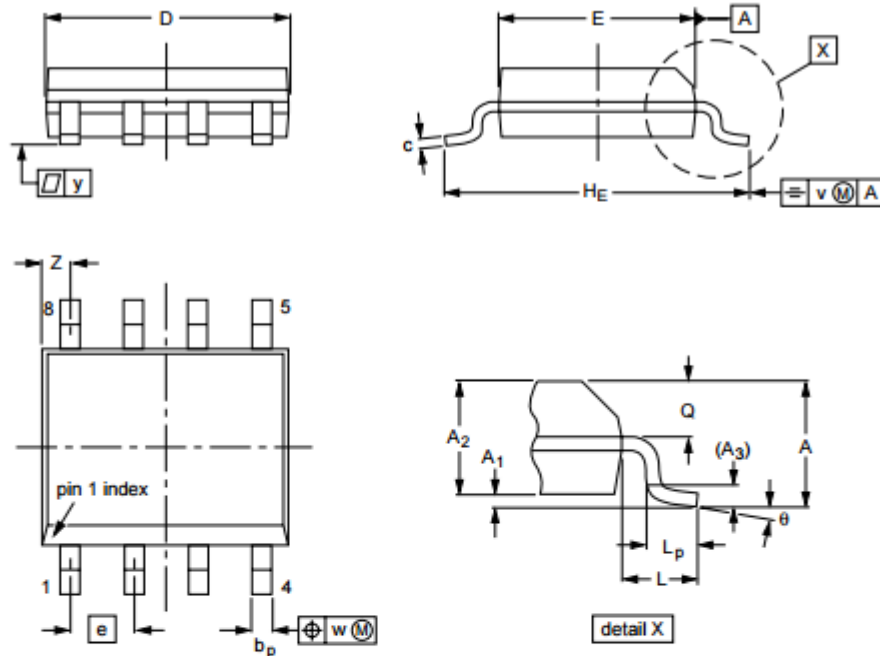

**DIMENSIONS** (inch dimensions are derived from the original mm dimensions)

UNIT	A max.	A <sub>1</sub>	A <sub>2</sub>	A <sub>3</sub>	b <sub>p</sub>	c	D <sup>(1)</sup>	E <sup>(2)</sup>	e	H <sub>E</sub>	L	L <sub>p</sub>	Q	v	w	y	Z <sup>(1)</sup>	θ
mm	1.75	0.25 0.10	1.45 1.25	0.25	0.49 0.36	0.25 0.19	5.0 4.8	4.0 3.8	1.27	6.2 5.8	1.05	1.0 0.4	0.7 0.6	0.25	0.25	0.1	0.7 0.3	8° 0°
inches	0.069	0.010 0.004	0.057 0.049	0.01	0.019 0.014	0.0100 0.0075	0.20 0.19	0.16 0.15	0.05	0.244 0.228	0.041	0.039 0.016	0.028 0.024	0.01	0.01	0.004	0.028 0.012	

**Notes**

1. Plastic or metal protrusions of 0.15 mm (0.006 inch) maximum per side are not included.
2. Plastic or metal protrusions of 0.25 mm (0.01 inch) maximum per side are not included.