

Model PA Amplified Piezoelectric Accelerometer

Order Code AG714

- Enhanced Sensitivity
- Case Isolated
- Rugged, High Impact



Dimensions

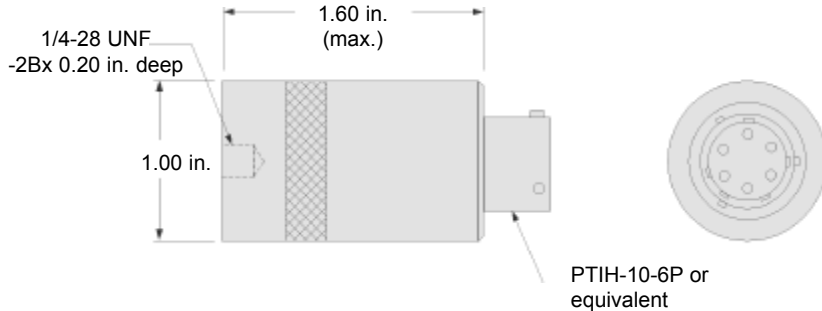

Wiring Codes

- A (+) 13.5 to 16.5 VDC
- B (-) Output/ Supply common
- C (-) 13.5 to 16.5 VDC
- D (+) Output (+/- 5 VDC)
- E Not Applicable
- F Not Applicable

Performance

Dynamic Range.....+/- 5 to +/- 1,000 G
 Sensitivity.....See table
 Frequency Range.....3 to 5,000 Hz
 Full Scale Output.....+/- 5 V
 Mounted Natural Frequency.....30 kHz
 Transverse Sensitivity.....5% of Full Scale

Environmental

Shock Limits.....3,000 G
 Vibration Limits.....2,000 G
 Temperature, Operating.....32° to 160° F

Electrical

Input Power.....+/- 13.5 to +/- 16.5 VDC
 Output Impedance.....100 Ohms
 Connector.....PTIH-10-6P

Mechanical

Weight.....3 oz.
 Case Material.....316 Stainless Steel
 Sealing.....Welded

Typical System Diagram

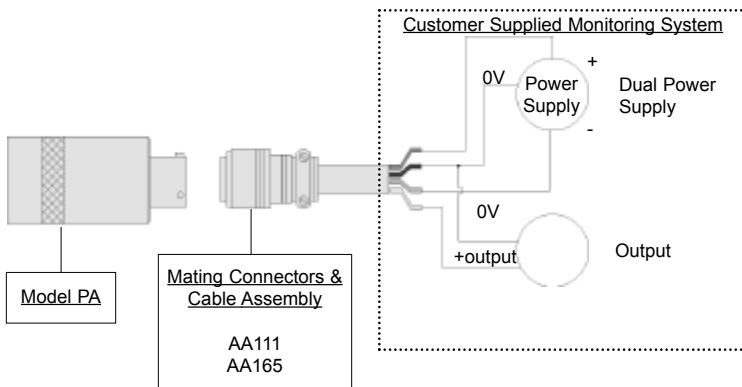

Range Codes

Range (G)	Sensitivity (mV/G)	Range Code
5	1,000	GJ
10	500	GK
50	100	GN
100	50	GP
500	10	GR
1,000	5	GS

-Not RoHS Compliant

How to Order

The order code consists of the product model and the desired range code.

Sample Code: **AG714** **GJ**
 Model Code Range Code

1-888-282-9891

www.honeywell.com/sensotec