

BD681

NPN Power Darlington Transistors



Feature:

- NPN Plastic Power Darlington Transistors.

TO-126 Plastic Package

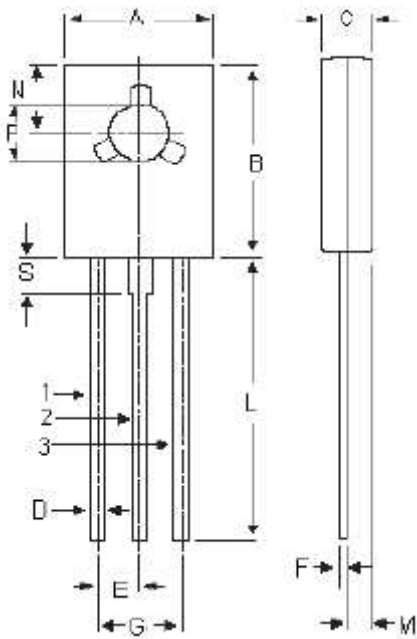

Dimensions	Minimum	Maximum
A	7.4	7.8
B	10.5	10.8
C	2.4	2.7
D	0.7	0.9
E	2.25 (Typical)	
F	0.49	0.75
G	4.5 (Typical)	
L	15.7 (Typical)	
M	1.27 (Typical)	
N	3.75 (Typical)	
P	3.0	3.2
S	2.5 (Typical)	

Dimensions : Millimetres

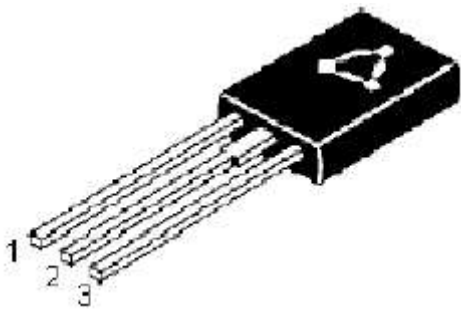

Pin Configuration:

1. Emitter
2. Collector
3. Base

BD681

NPN Power Darlington Transistors

Absolute Maximum Ratings

Parameter	Symbol	BD681	Unit
Collector Base Voltage	V_{CBO}	100	V
Collector Emitter Voltage	V_{CEO}		
Emitter Base Voltage	V_{EBO}		
Collector Current	I_C	4.0	A
Base Current	I_B	0.1	
Total Power Dissipation at $T_j = 25^\circ\text{C}$ Derate above 25°C	P_D	1.25	W
Total Power Dissipation at $T_j = 25^\circ\text{C}$ Derate above 25°C		10	mW/ $^\circ\text{C}$
Operating and Storage Junction Temperature Range	T_j, T_{stg}	-55 to +150	$^\circ\text{C}$
Thermal Resistance			
Junction to Case	$R_{th(j-c)}$	3.13	$^\circ\text{C/W}$
Junction to Ambient in Free Air	$R_{th(j-a)}$	100	

Electrical Characteristics ($T_j = 25^\circ\text{C}$ unless specified otherwise)

Parameter	Symbol	Test Condition	Minimum	Maximum	Unit
Collector Emitter Voltage	V_{CEO}^*	$I_C = 50\text{mA}, I_B = 0$ BD681	100	-	V
Collector Cut off Current	I_{CEO}	$V_{CE} = \text{Half Rated } V_{CEO}, I_B = 0$ $V_{CB} = \text{Rated } V_{CBO}, I_E = 0$	-	500	μA
	I_{CBO}	$V_{CB} = \text{Rated } V_{CBO}, I_E = 0$ $T_C = 100^\circ\text{C}$	-	0.2	mA
Emitter Cut off Current	I_{EBO}	$V_{EB} = 5\text{V}, I_C = 0$	-	2.0	mA
Collector Emitter Saturation Voltage	$V_{CE(sat)}^*$	$I_C = 1.5\text{A}, I_B = 6\text{mA}$	-	2.5	V
Base Emitter On Voltage	$V_{EB(on)}^*$	$I_C = 1.5\text{A}, V_{CE} = 3\text{V}$	-		
DC Current Gain	h_{FE}^*	$I_C = 1.5\text{A}, V_{CE} = 3\text{V}$	750	-	-
Small Signal Current Gain	$ h_{fe} $	$I_C = 1.5\text{A}, V_{CE} = 3\text{V}$ $f = 1\text{MHz}$	1.0	-	-

*Pulse Test : Pulse Width $\leq 30\mu\text{s}$, Duty Cycle $\leq 2\%$.

BD681

NPN Power Darlington Transistors

Specifications

V_{CE0} Maximum (V)	V_{CBO} Maximum (V)	I_C (av) Maximum (A)	h_{FE} Minimum at $I_C = 1.5A$	Package	Type	Part Number
100	100	4	750	TO-126	NPN	BD681