

GaAs MMIC

CF 750

Data Sheet

- Biased Dual Gate GaAs FET
- For frequencies from 400 MHz to 3 GHz
- For mixer and amplifier applications, i.e LNA- and buffer stages in handheld equipment
- Low power consumption, 2 mA operating current typ.
- Operating voltage range: 3 to 6 V
- Ion-implanted planar structure

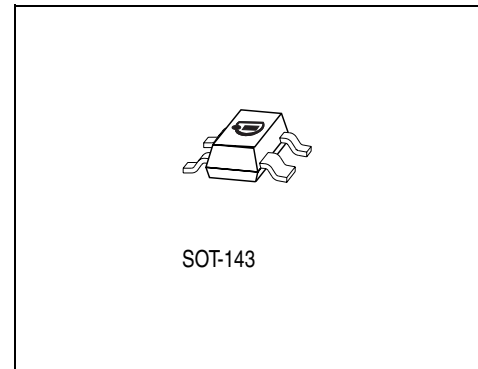

ESD: Electrostatic discharge sensitive device, observe handling precautions!

Type	Marking	Ordering Code (taped)	Pin Configuration				Package ¹⁾
			1	2	3	4	
CF 750	MX	Q62702-F1391	GND	D	G	S	P-SOT143-4-1

¹⁾ For detailed dimensions see **Page 9**.

Maximum Ratings

Parameter	Symbol	Value	Unit
Drain-source voltage	V_{DS}	8	V
Gate-source voltage	$-V_{GS}$	5	V
Drain current	I_D	80	mA
Gate-source peak current	$+I_{GSM}$	2	mA
Channel temperature	T_{Ch}	150	°C
Storage temperature range	T_{stg}	- 55 ... + 150	°C
Total power dissipat. ($T_S < 48 \text{ °C}$) ¹⁾	P_{tot}	300	mW

¹⁾ T_S : Temperature measured at soldering point

Thermal Resistance

Parameter	Symbol	Value	Unit
Channel-soldering point (GND)	$R_{thChGND}$	340	K/W

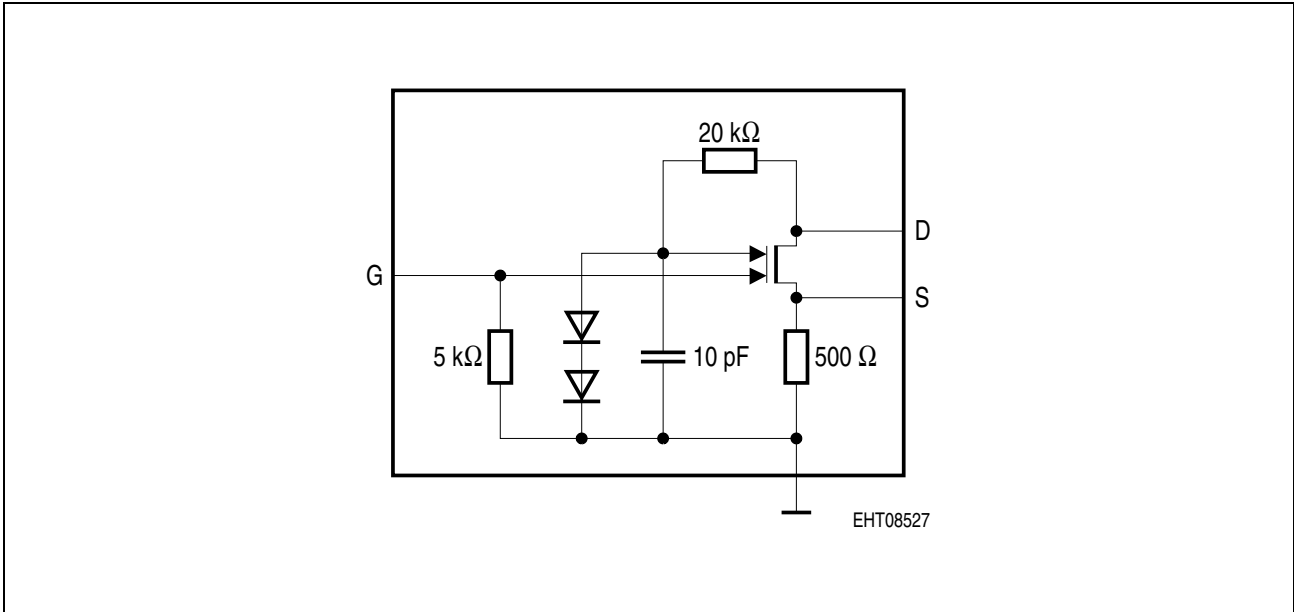

Figure 1 Circuit Diagram

Electrical Characteristics

$T_A = 25\text{ °C}$, unless otherwise specified

DC Characteristics	Symbol	Limit Values			Unit	Test Conditions
		min.	typ.	max.		
Drain-Source Breakdown Voltage	$V_{DS(BR)}$	8	–	–	V	$I_D = 500\text{ }\mu\text{A}$, $-V_{GS} = 4\text{ V}$
Drain Current S-pin not connected	$I_{DSS,P}$	1.6	2	2.8	mA	$V_{GGND} = 0\text{ V}$, $V_{DS} = 3.8\text{ V}$
Drain Current S-pin connected to GND	I_{DSS}	–	50	–	mA	$V_{GS} = 0\text{ V}$, $V_{DS} = 3.8\text{ V}$
Transconductance S-pin connected to GND	g_m	–	25	–	mS	$I_D = 10\text{ mA}$, $V_{DS} = 3.8\text{ V}$

Electrical Characteristics of CF 750 in Amplifier Application
 $T_A = 25\text{ °C}$, $V_{DGND} = 3.8\text{ V}$, $R_S = R_L = 50\ \Omega$, unless otherwise specified.

Amplifier Application	Symbol	Limit Values			Unit	Test Conditions
		min.	typ.	max.		
Power Gain	G_{PS}	–	11	–	dB	$I_D = 2\text{ mA}$, $f = 900\text{ MHz}$
Noise Figure	NF	–	1.6	–	dB	$I_D = 2\text{ mA}$, $f = 900\text{ MHz}$
3 rd Order Intermodulation	$IPIP3$	–	– 1	–	dBm	$I_D = 2\text{ mA}$, $f = 900\text{ MHz}$
3 rd Order Intermodulation	$OPIP3$	–	10	–	dBm	$I_D = 2\text{ mA}$, $f = 900\text{ MHz}$
Power Gain	G_{PS}	–	10	–	dB	$I_D = 2\text{ mA}$, $f = 1.8\text{ GHz}$
Noise Figure	F	–	1.9	–	dB	$I_D = 2\text{ mA}$, $f = 1.8\text{ GHz}$
3 rd Order Intermodulation	$IPIP3$	–	– 1	–	dBm	$I_D = 2\text{ mA}$, $f = 1.8\text{ GHz}$
3 rd Order Intermodulation	$OPIP3$	–	9	–	dBm	$I_D = 2\text{ mA}$, $f = 1.8\text{ GHz}$

Electrical Characteristics of CF 750 in Mixer Application
 $T_A = 25\text{ °C}$, $V_{\text{DGND}} = 3.8\text{ V}$, $R_S = R_L = 50\ \Omega$, unless otherwise specified.

Mixer Application	Symbol	Limit Values			Unit	Test Conditions
		min.	typ.	max.		
Single Sideband Noise Figure	F_{SSB}	–	4.5	–	dB	$f_{\text{RF}} = 945\text{ MHz}$, $f_{\text{LO}} = 900\text{ MHz}$ $f_{\text{IF}} = 45\text{ MHz}$, $P_{\text{LO}} = 3\text{ dBm}$
Conversion Gain	G_A	–	15	–	dB	$f_{\text{RF}} = 945\text{ MHz}$, $f_{\text{LO}} = 900\text{ MHz}$ $f_{\text{IF}} = 45\text{ MHz}$, $P_{\text{LO}} = 3\text{ dBm}$
3 rd Order Intermodulation	$IPIP3$	–	– 5	–	dBm	$f_{\text{RF}} = 945\text{ MHz}$, $f_{\text{LO}} = 900\text{ MHz}$ $f_{\text{IF}} = 45\text{ MHz}$, $P_{\text{LO}} = 3\text{ dBm}$
3 rd Order Intermodulation	$OPIP3$	–	10	–	dBm	$f_{\text{RF}} = 945\text{ MHz}$, $f_{\text{LO}} = 900\text{ MHz}$ $f_{\text{IF}} = 45\text{ MHz}$, $P_{\text{LO}} = 3\text{ dBm}$

Typical Common Source S-Parameters

 Bias conditions: $V_{\text{DGND}} = 3.8 \text{ V}$, $I_{\text{D}} = 2 \text{ mA}$

Source-Pad RF-grounded by capacitor with low inductance (< 0.5 nH)!

<i>f</i>	S11		S21		S12		S22	
	MAG	ANG	MAG	ANG	MAG	ANG	MAG	ANG
0.01	0.97	- 1	1.78	179	0.002	89	0.98	- 1
0.1	0.97	- 3	1.78	175	0.008	84	0.98	- 2
0.25	0.96	- 8	1.76	169	0.015	78	0.97	- 6
0.5	0.94	- 16	1.73	155	0.027	75	0.95	- 11
0.75	0.91	- 26	1.70	141	0.039	71	0.93	- 16
1.00	0.87	- 34	1.68	127	0.046	64	0.91	- 22
1.25	0.83	- 42	1.65	118	0.052	62	0.89	- 26
1.5	0.87	- 49	1.62	108	0.061	57	0.88	- 30
1.75	0.72	- 57	1.59	95	0.066	55	0.87	- 34
2.00	0.66	- 65	1.54	82	0.069	52	0.86	- 38
2.25	0.61	- 73	1.51	71	0.071	54	0.85	- 43
2.5	0.56	- 81	1.47	60	0.073	60	0.84	- 48
2.75	0.52	- 87	1.45	52	0.074	63	0.83	- 52
3.00	0.49	- 93	1.42	45	0.075	66	0.82	- 56

Typical Common Source Noise Parameters

 Bias conditions: $V_D = 3\text{ V}$, $I_D = 2\text{ mA}$, $Z = 50\ \Omega$

f	$\Gamma_{\text{opt}} (F)$		R_n	$R_n/50\ \Omega$	F_{min}
	MAG	ANG			
200	0.80	5	75	1.50	1.2
450	0.79	12	60	1.20	1.2
800	0.68	23	51	1.02	1.5
900	0.63	26	49	0.98	1.6
1200	0.58	34	45	0.90	1.7
1500	0.54	42	40	0.80	1.8
1800	0.52	51	36	0.72	1.9
1900	0.50	53	35	0.70	1.9

**Output Characteristics $I_D = f(V_{DGND})$;
at Nominal Operating Point;
S not Connected**

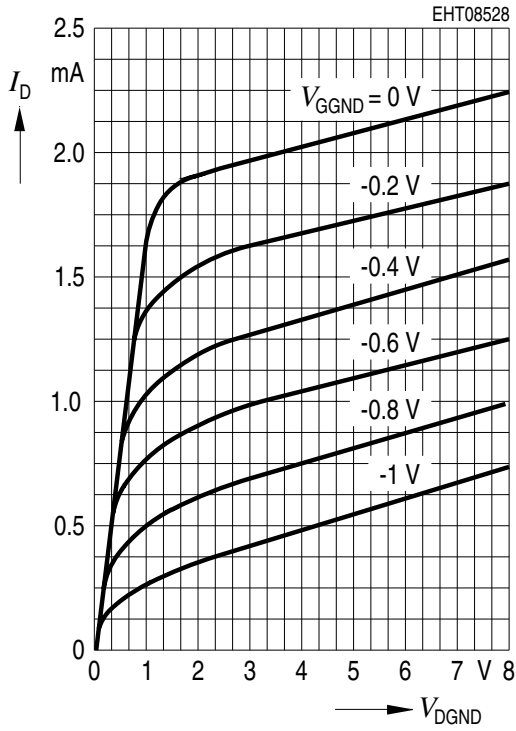

**Output Characteristics $I_D = f(V_{DS})$;
S Connected to GND**

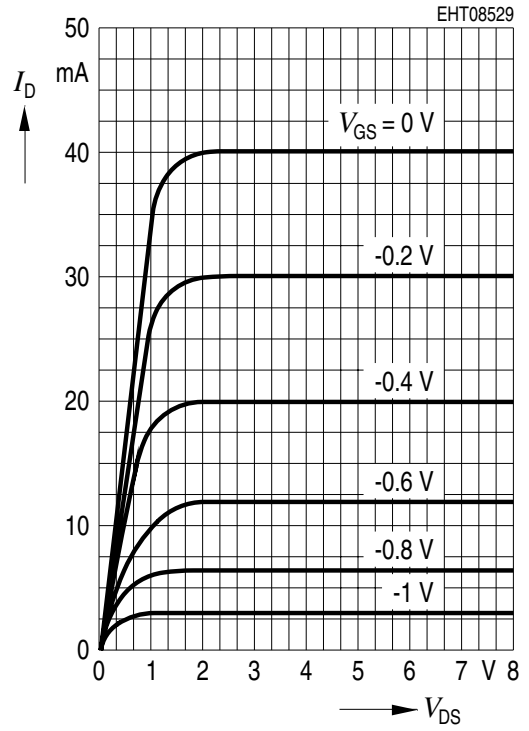

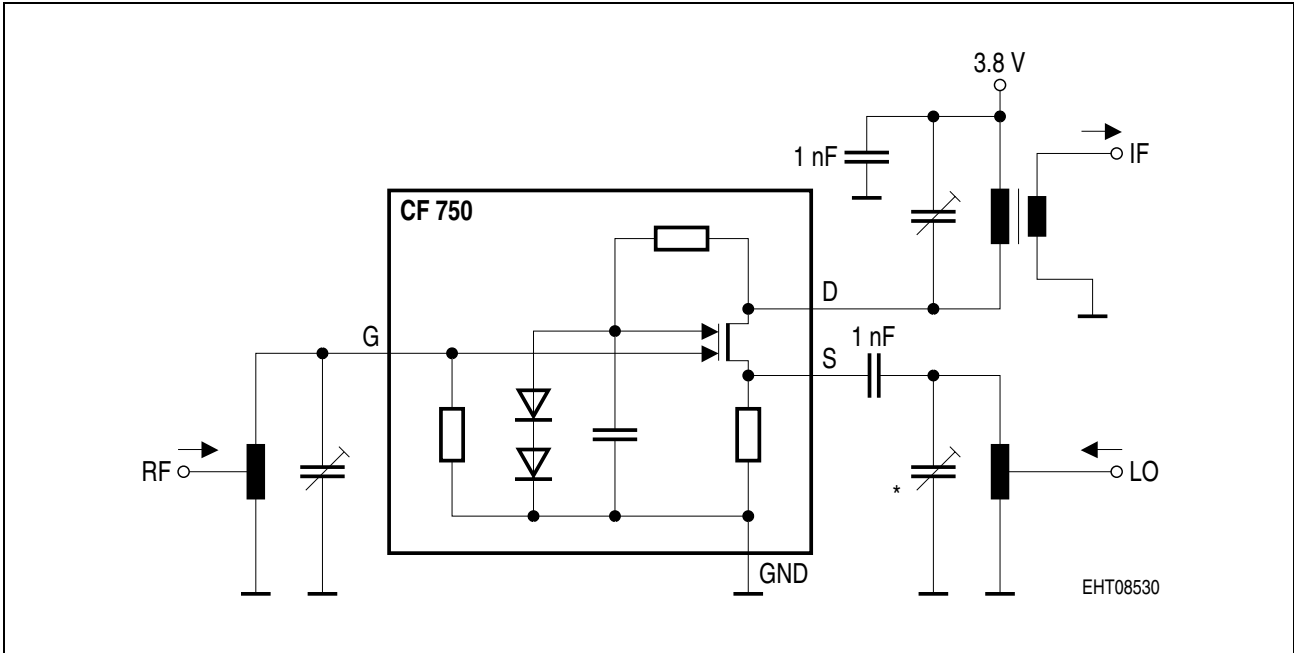

Figure 2 Mixer Measurement and Application Circuit (No. 1)

* must be high capacitance to ensure good IF grounding at source

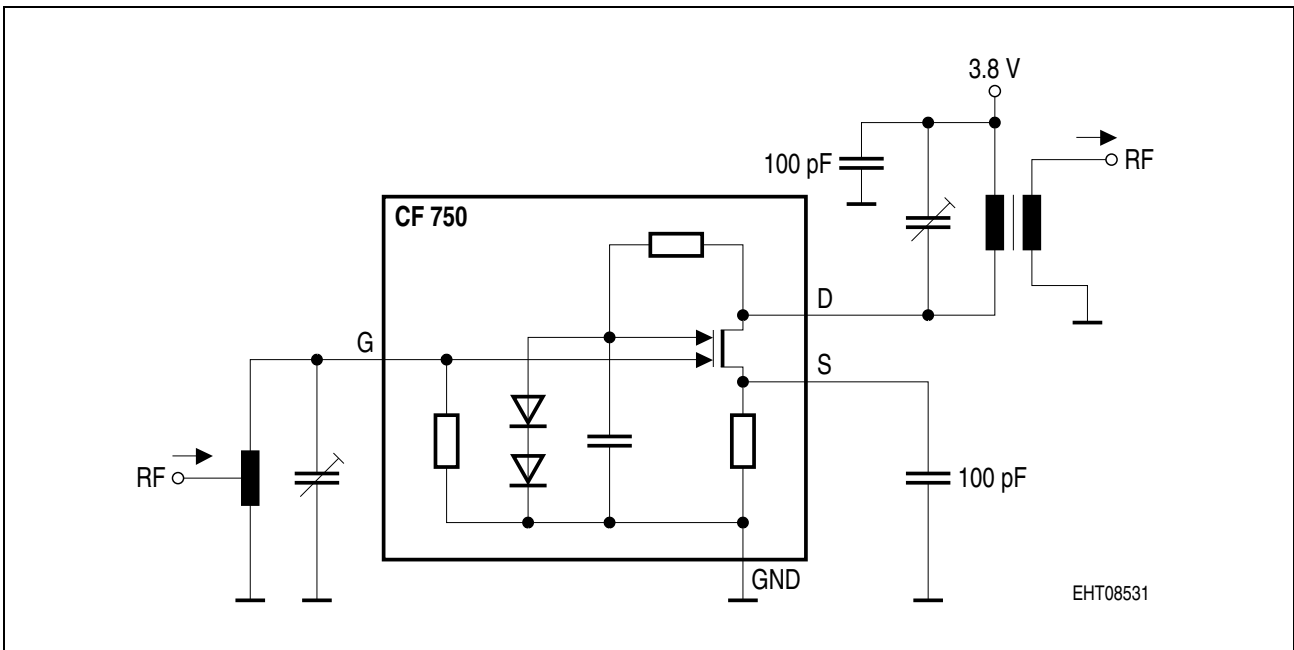
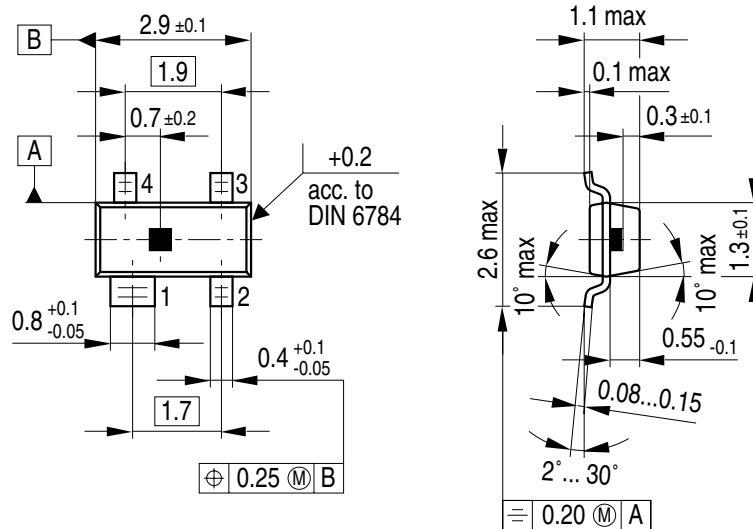

Figure 3 Amplifier Measurement and Application Circuit (No. 2)

Package Outlines

P-SOT143-4-1
(Small Outline Transistor)



GPS05559

Sorts of Packing

Package outlines for tubes, trays etc. are contained in our Data Book "Package Information".

SMD = Surface Mounted Device

Dimensions in mm