

Description

The DFI150HF12DE1 offer ultrafast switching speed for high frequency application.

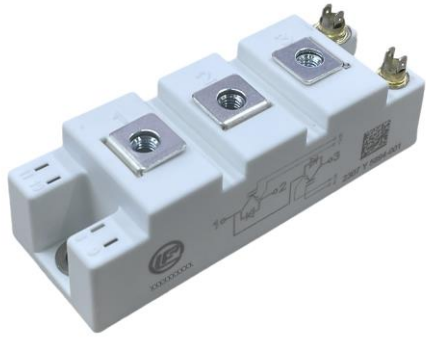

Features

- 1200V150 A, $V_{CE(sat)}(typ.) = 2.30V$
- Lower losses
- SPT (Soft Punch Through) technology
- Excellent short-circuit capability
- 34mm half bridge module

Applications

- Welding
- Motor drive
- Inductive heating
- Power supply
- UPS / EPS

Circuit diagram

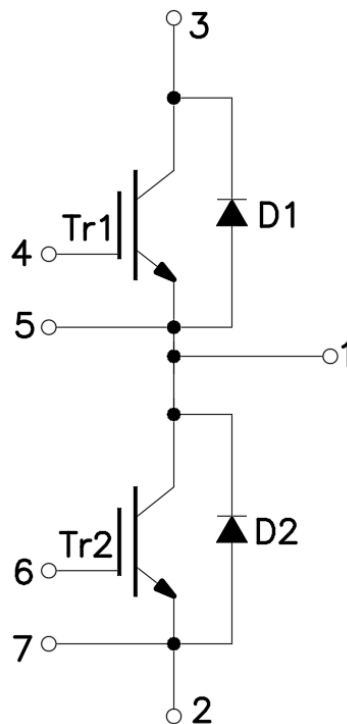

Figure 1. Out drawing & circuit diagram for DFI150HF12DE1

Pin Configuration and Marking Information

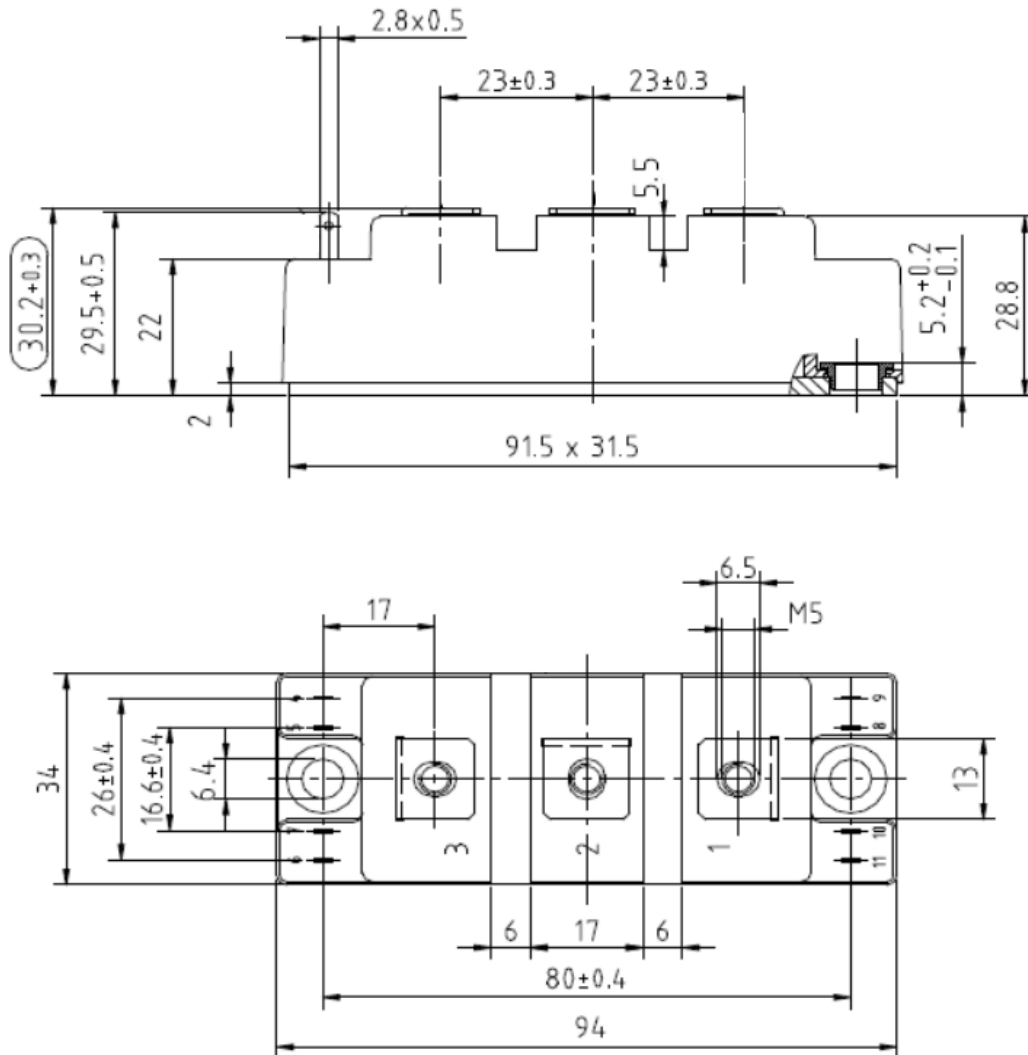

Figure 2. Pin configuration

Module

Parameter	Conditions	Value	Unit
Isolation Voltage	RMS, f = 50Hz, t = 1 min	2.5	KV
Material of module baseplate	-	Cu	-
Creepage distance	terminal to heatsink terminal to terminal	26 21	mm
Clearance	terminal to heatsink terminal to terminal	23.6 10	mm
CTI	-	>200	-
Module lead resistance, terminals – chip	T _c = 25°C	0.8	mΩ
Mounting torque for module mounting	M5, M6	3 to 6	Nm
Weight	-	160	g

Maximum Ratings (IGBT, $T_j=25^\circ\text{C}$ unless otherwise specified)

Symbol	Parameter	Conditions	Ratings	Unit
V_{CES}	Collector-Emitter Voltage	G-E Short	1200	V
V_{GES}	Gate-Emitter Voltage	C-E Short	$\pm 30\text{V}$	V
I_C	DC Continuous Collector Current	$T_C=100^\circ\text{C}$	150	A
I_{CM}	Pulse Collector Current	$t_p=1\text{ms}$, Note1	300	A
P_C	Maximum Power Dissipation	$T_C=25^\circ\text{C}$, $T_j=150^\circ\text{C}$ (IGBT)	500	W
T_{jop}	junction temperature	-	-40 to 150	$^\circ\text{C}$
T_{stg}	Storage temperature	-	-40 to 125	$^\circ\text{C}$

Note1: Pulse width limited by maximum junction temperature

Maximum Ratings (Freewheeling diode, $T_j=25^\circ\text{C}$ unless otherwise specified)

Symbol	Parameter	Conditions	Ratings	Unit
V_{RRM}	Peak Repetitive Revers Voltage	-	1200	V
I_F	Diode forward Current	- $T_C=100^\circ\text{C}$	150	A
I_{FRM}	Repetitive peak forward Current	$t_p=1\text{ms}$, Note1	300	A
T_{jop}	junction temperature	-	-40 to 150	$^\circ\text{C}$
T_{stg}	Storage temperature	-	-40 to 125	$^\circ\text{C}$

Note1: Pulse width limited by maximum junction temperature

IGBT Electrical characteristics ($T_j=25^\circ\text{C}$ unless otherwise specified, chip)

Symbol	Item	Condition		Value			Unit
				Min.	Typ.	Max	
$V_{CE(sat)}$	Collector-Emitter Saturation Voltage	$I_C=150\text{A}$ $V_{GE}=15\text{V}$	$T_j=25^\circ\text{C}$	-	2.30	2.50	V
			$T_j=125^\circ\text{C}$	-	2.70	-	V
$V_{GE(th)}$	Gate-Emitter threshold Voltage	$I_C=1\text{mA}$, $V_{CE}=V_{GE}$		4.5	-	5.7	V
Q_G	Gate charge	$V_{GE} = -15\text{V to } +15\text{V}$		-	1140	-	nC
R_{Gint}	Internal gate resistor	$f=1\text{M}$, $V_{pp}=1\text{V}$	$T_j=25^\circ\text{C}$	-	2.5	-	Ω
C_{ies}	Input Capacitance	$V_{CE}=25\text{V}$, $V_{GE}=0\text{V}$ $f=1\text{MHz}$	$T_j=25^\circ\text{C}$	-	10.8	-	nF
C_{oes}	Output Capacitance			-	1.65	-	nF
C_{res}	Reverse transfer Capacitance			-	0.94	-	nF
I_{CES}	Collector- Emitter Cut off Current	$V_{CE}=1200\text{V}$, $V_{GE}=0\text{V}$	$T_j=25^\circ\text{C}$	-	-	1	mA
I_{GES}	Gate-Emitter Leakage Current	$V_{GE} = \pm 30\text{V}$, $V_{CE}=0\text{V}$	$T_j=25^\circ\text{C}$	-	-	200	nA
$t_{d(on)}$	Turn-on delay time	$V_{CC} = 600\text{V}$ $I_C = 150\text{A}$ $R_G = 4.7\Omega$ $V_{GE} = \pm 15\text{V}$ Inductive Load	$T_j=25^\circ\text{C}$	-	35	-	ns
			$T_j=125^\circ\text{C}$	-	40	-	
t_r	Rise time		$T_j=25^\circ\text{C}$	-	55	-	ns
			$T_j=125^\circ\text{C}$	-	60	-	
$t_{d(off)}$	Turn-off delay time	$T_j=25^\circ\text{C}$	-	340	-	ns	
		$T_j=125^\circ\text{C}$	-	370	-		

t_f	Fall time	$V_{CC} = 600V$ $I_C = 150A$	$T_j = 25^\circ C$	-	90	-	ns
			$T_j = 125^\circ C$	-	120	-	
E_{on}	Turn-on power dissipation	$R_G = 4.7\Omega$ $V_{GE} = \pm 15V$	$T_j = 25^\circ C$	-	6.30	-	mJ
			$T_j = 125^\circ C$	-	8.00	-	
E_{off}	Turn-off power dissipation	Inductive Load	$T_j = 25^\circ C$	-	4.10	-	mJ
			$T_j = 125^\circ C$	-	7.20	-	
$R_{th(j-c)}$	Thermal Resistance, Junction to Case (IGBT)		-	-	0.25	-	$^\circ C/W$

Freewheeling Diode Electrical characteristics ($T_j = 25^\circ C$ unless otherwise specified, chip)

Symbol	Item	Condition	Value			Unit	
			Min.	Typ.	Max		
V_F	Diode Forward Voltage	$I_F = 150A, V_{GE} = 0V$	$T_j = 25^\circ C$	-	1.90	2.2	V
			$T_j = 125^\circ C$	-	1.90	-	
t_{rr}	Diode Reverse Recovery Time		$T_j = 25^\circ C$		150		nS
			$T_j = 125^\circ C$		200		
I_{rr}	Peak reverse recovery Current	$I_F = 150A,$ $di/dt = 2600A/\mu s,$	$T_j = 25^\circ C$	-	165	-	A
			$T_j = 125^\circ C$	-	190	-	
Q_{rr}	Recovered charge	$V_R = 600V,$ $V_{GE} = -15V$	$T_j = 25^\circ C$	-	14.50	-	uC
			$T_j = 125^\circ C$	-	21.00	-	
E_{rr}	Reverse recovered energy		$T_j = 25^\circ C$	-	4.5	-	mJ
			$T_j = 125^\circ C$	-	7.3	-	
$R_{th(j-c)}$	Thermal Resistance, Junction to Case (Diode)		-	-	0.38	-	$^\circ C/W$

Test Conditions



Figure 3. Switching time measure circuit

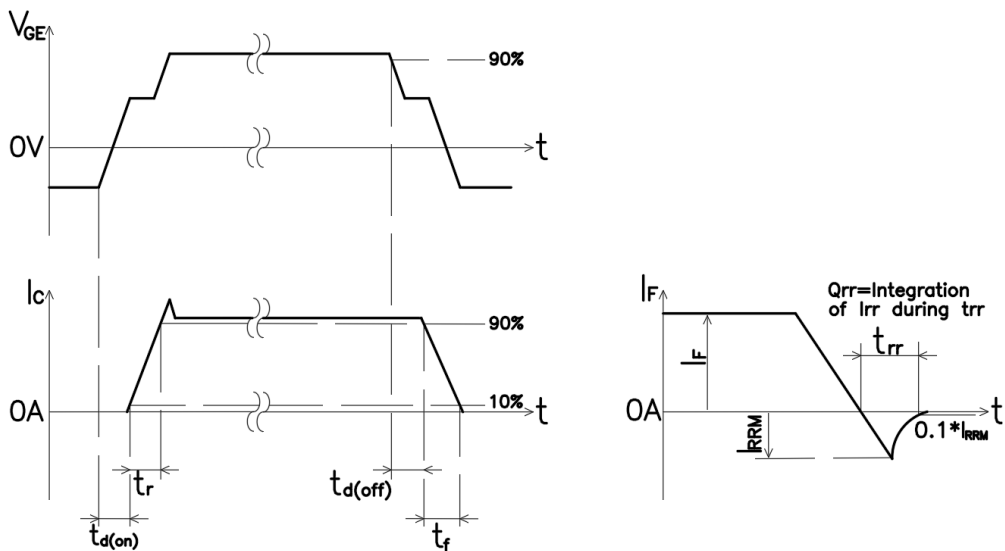

Figure 4. Switching time definition

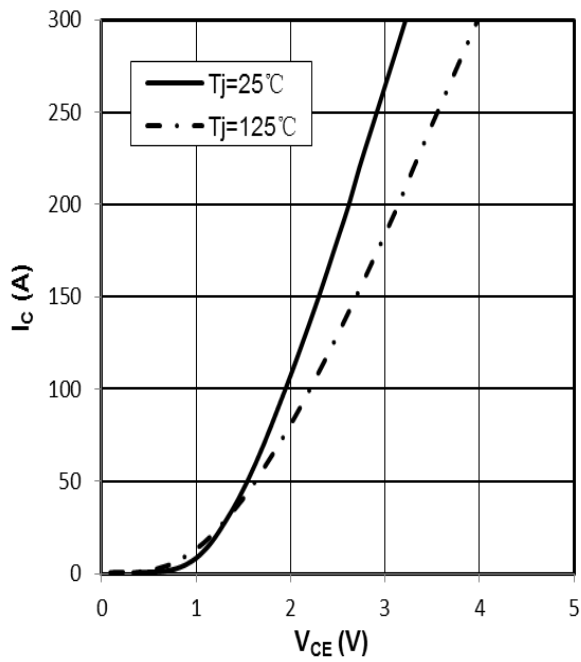

Figure 5. I_c vs V_{CE}
 $V_{GE}=15V$

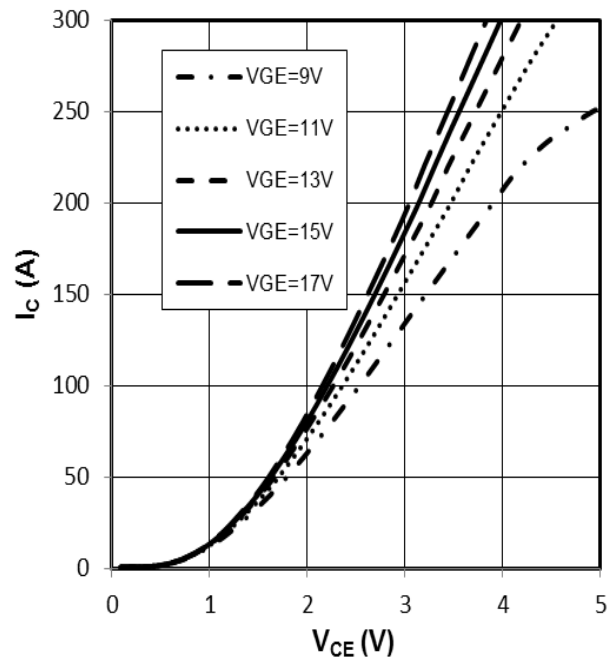

Figure 6. I_c vs V_{CE}
 $T_j=125^\circ C$

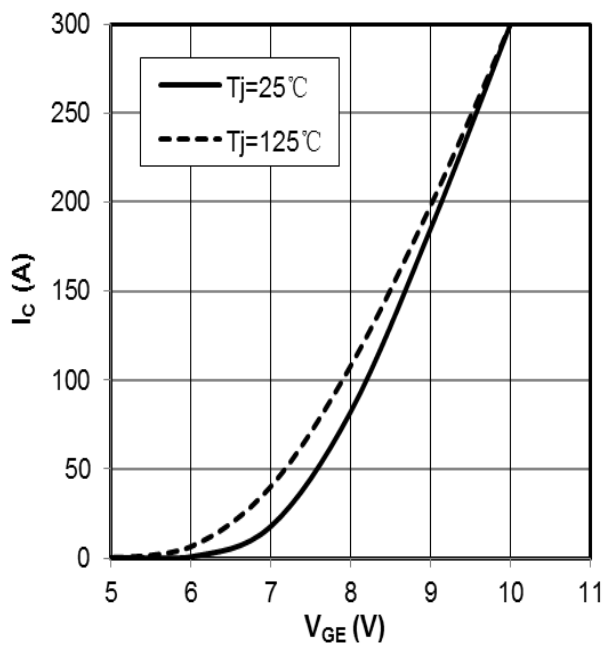

Figure 7. I_c vs V_{GE}
 $V_{CE}=20V$

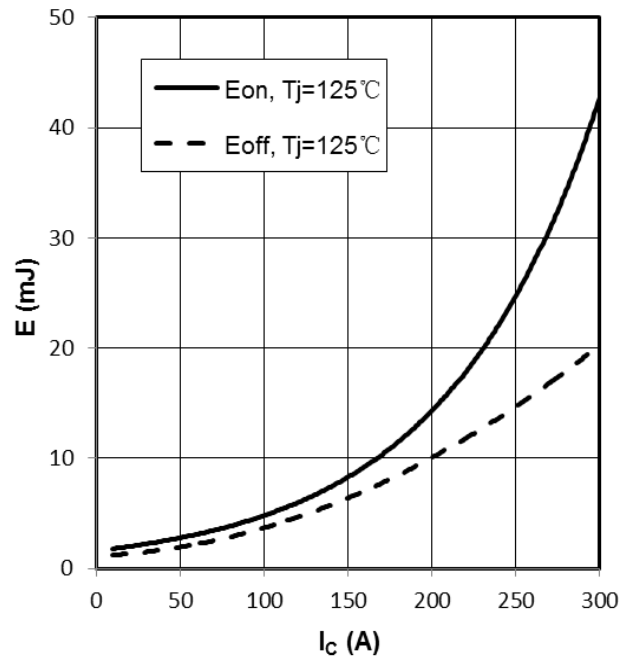

Figure 8. E_{on}, E_{off} vs I_c (Typ)
 $V_{CC}=600V, V_{GE}=+15V/-15V, R_G=4.7\Omega$

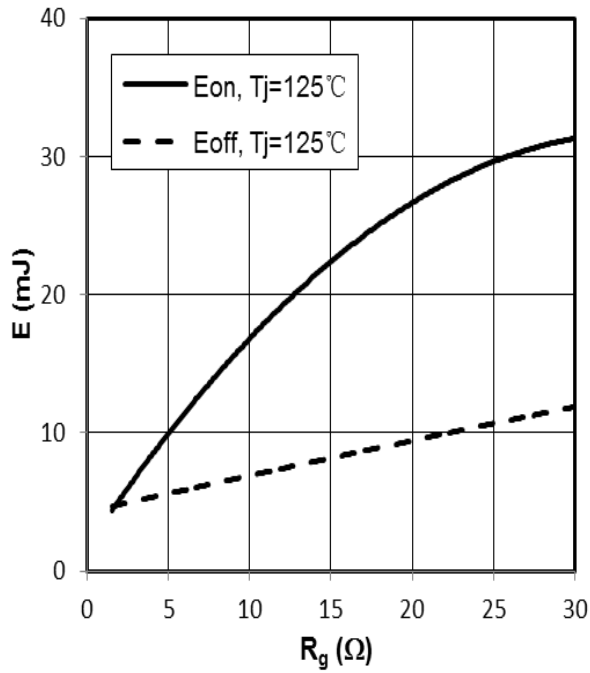

Figure 9. E_{on} , E_{off} vs R_g (Typ)
 $V_{CC}=600\text{V}$, $V_{GE}=\pm 15\text{V}/-15\text{V}$, $I_C=150\text{A}$

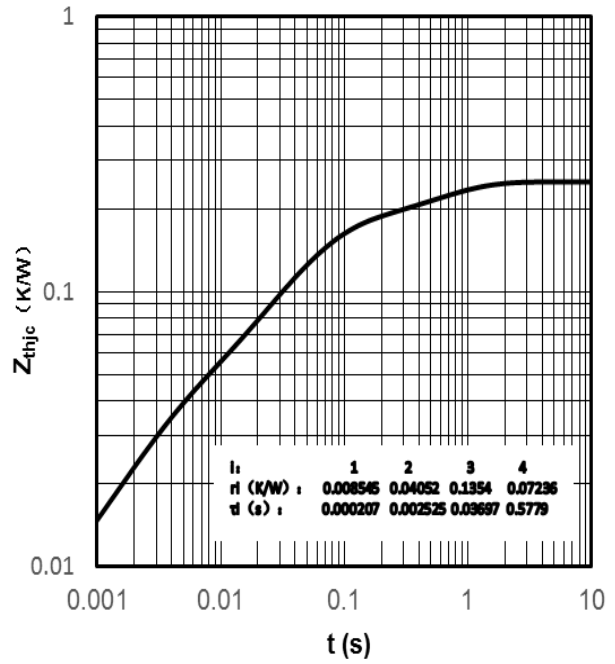

Figure 10. Transient thermal impedance IGBT, $Z_{thjc}=f(t)$

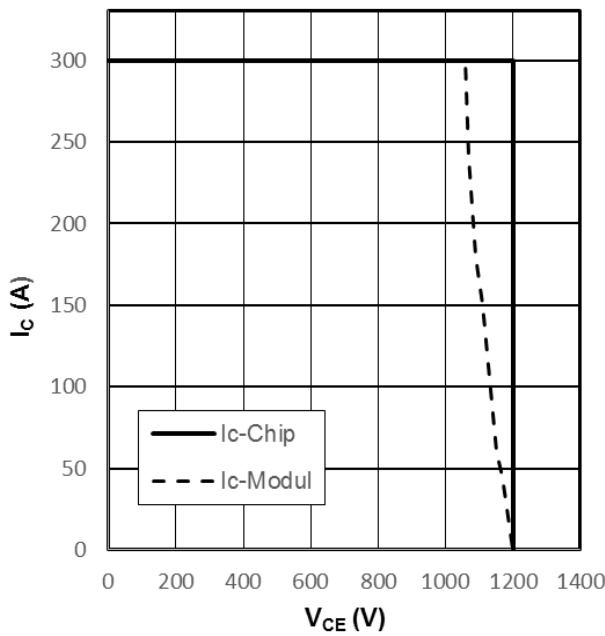

Figure 11. Reverse bias safe operating area IGBT,
 $I_C=f(V_{CE})$, $V_{GE}=\pm 15\text{V}$, $R_{Goff}=4.7\Omega$, $T_{vj}=125^\circ\text{C}$

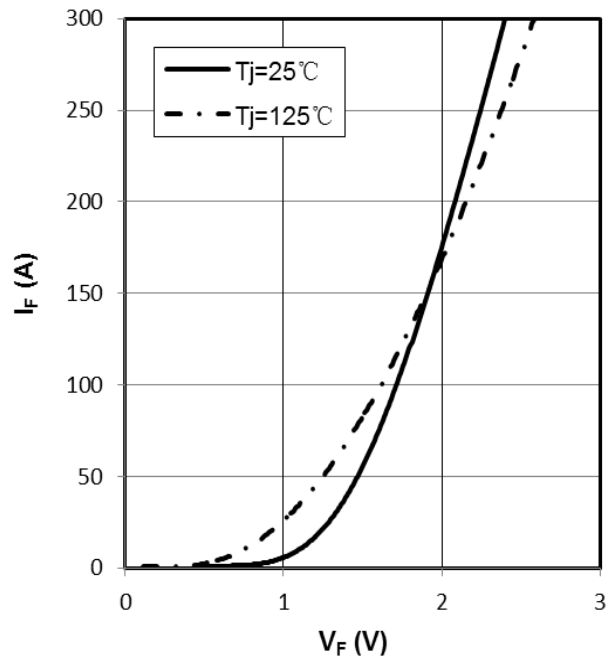
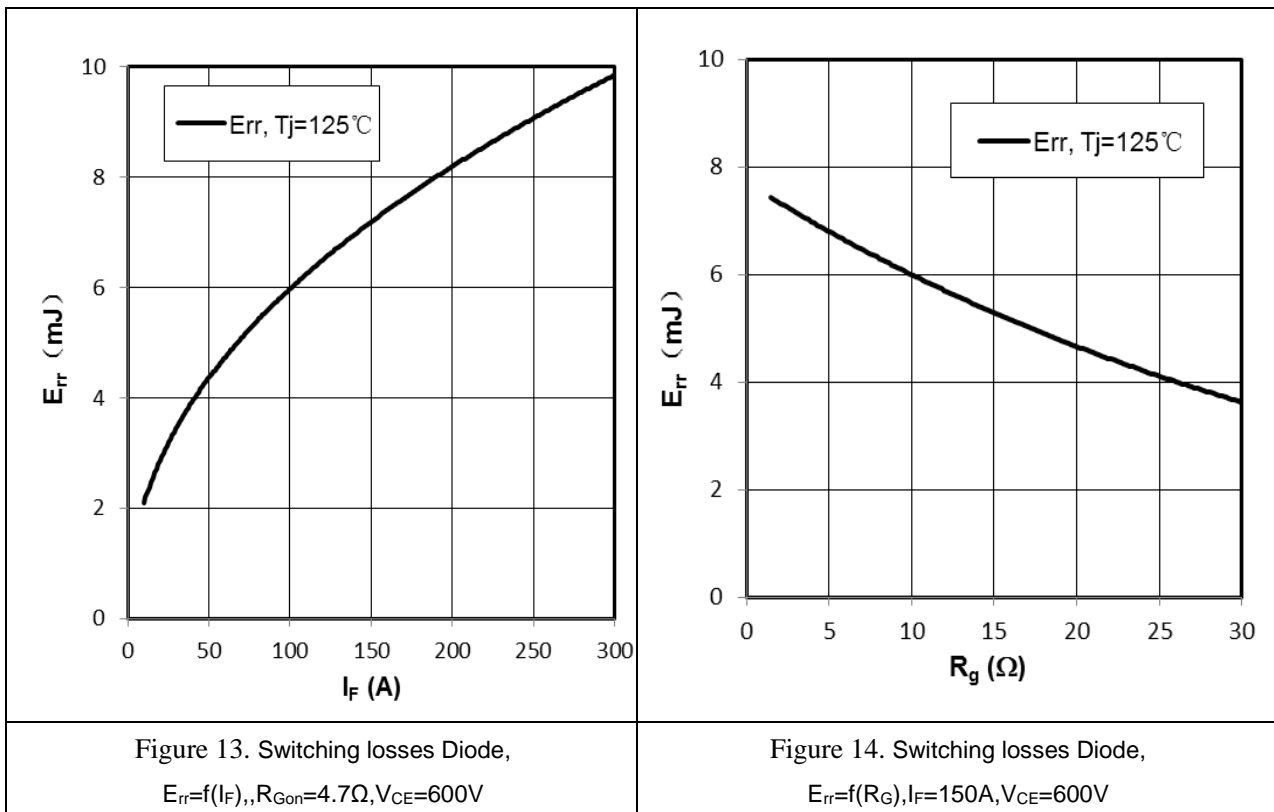

Figure 12. Forward characteristic of Diode,
 $I_F=f(V_F)$



IMPORTANT NOTICE:

This product data sheet describes the characteristics of this product for which a warranty is granted. Any such warranty is granted exclusively under the terms and conditions of the supply agreement. There will be no guarantee or of any kind for the product and its characteristics.

The data contained in this document is exclusively intended for technically trained staff. You and your technical departments will have to evaluate the product's suitability for the intended application and the completeness of the product data concerning such application.

Due to technical requirements, our product may contain dangerous substances. For information on the types in question, please contact the sales staff responsible for you.

Changes to this product data sheet are reserved.

Please contact the sales staff (Sales@leapers-power.com) for further information on the product, technology, delivery terms, conditions and prices.