



承 认 书

SPECIFICATION FOR APPROVAL

客户名称 CUSTOMER: _____

品名 DESCRIPTION: 927833型端子承认图面

料号 CUSERTOMER PART NO: C5001-T

客户确认 APPROVED SIGNATURES

核准 APPROVAL: _____

日期 DATE: _____

工程 ENGINEERING: _____

日期 DATE: _____

品管 QC: _____

日期 DATE: _____

承认结果: 承认 不承认

重新送样

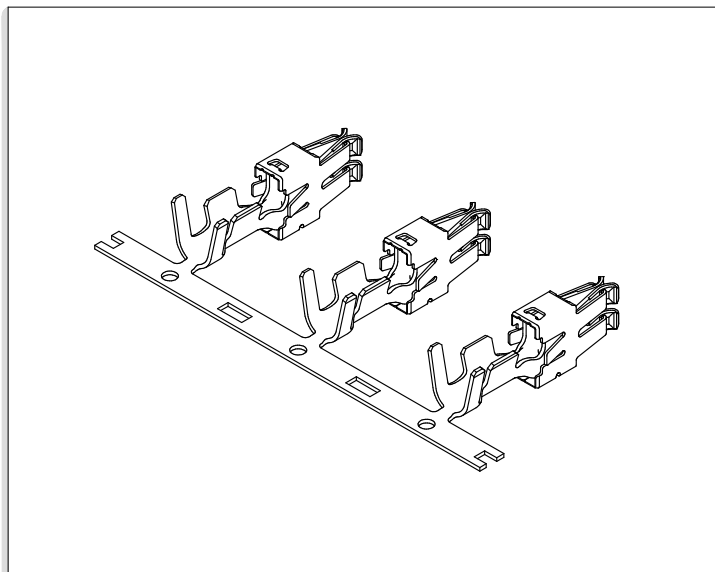

规格 Specifications

- 极数 Poles:
- 额定电流 Current rating: 6A~16A AC,DC
- 额定电压 Voltage rating: 250V AC,DC
- 温度范围 Temperature range: -40°C to +110°C
(含通电温度上升值)
(Including temperature rise in applying electrical current)
- 接触电阻 Contact resistance: 初期 Initial value / $\leq 10m\Omega$
环境测试后 After environmental testing / $\leq 20m\Omega$
- 绝缘电阻 Insulation resistance: $\geq 500M\Omega$
- 耐电压 Withstanding voltage: 3000V AC/minute
- 适用线规 Applicable wire: AWG #20 to #14
- 适用基板厚度 Applicable PC board thickness:



目录(COVER)	1
料号说明(DESCRIPTION OF ITEM NUMBER)	2
图纸(DRAWING)	3
产品性能测试(PERFORMANCE TEST)	5
认证(CERTIFICATION)	7
端子 RoHS报告(TERMINAL RoHS REPORT)	15
MSDS	22
反馈与建议(FEEDBACK AND SUGGESTIONS)	24

制订 Edit: 邱铭慧

日期 DATE: 2022-12-22

审核 Check: 陈浙海

日期 DATE: 2022-12-22

批准 Approval: 季育文

日期 DATE: 2022-12-22

端子料号说明 TERMINAL

C 5001 N - T 2 2 A 30 5 P 2

A: Wire to Board Connectors
 B: Board-in Connectors
 C: Wire to Wire Connectors
 F: FFC/FPC Connectors
 I: IDC
 D: Chain Terminals and Splices

系列号 Series Number

K=直形带锁 N=直形
 Z=旗形带锁 Q=旗形
 X=横插带锁 H=横插
 Y=叉形端子 J=插片
 R=环形端子 C=圆形
 G=接线端子
 W=鲨鱼齿端子
 特征类别(默认空) B=子弹形端子
 Feature Category: U=耳扒形端子

产品类别 Product Category: T=端子 Terminal

同类别多型号序号(默认空)
 Same Series Different Type: 1-9

同型号多尺寸序号(默认空)
 Same Type Different size: 1-9

适用线规(默认空) A=小脚 B=中脚
 Applicable Wire: C=高脚 D=大脚

料带厚度单位: mm X100 (0.3X100=30 默认空)

配合厚度单位: mm X10 (0.5X10=5 默认空)
 注: 所有<灰色>说明, 为D系列分类附加料号及说明!

Z=紫铜 Copper
 S=不锈钢 Stainless Steel
 P=磷青铜 Phos.Bronze
 材质 Material: B=黄铜 Brass

0=素材酸洗 None
 1=镀镍 Nickel Plating
 2=镀亮锡 Tin Plating
 3=镀镍光锡 Matt Tin-Nickel Plating
 4=镀铅锡 Tin-Lead Plating
 5=镀铜锡 Tin-Cu Plating
 6=镀镍银 Silver-Nickel Plating
 7=镀镍金 Gold-Nickel Plating
 8=镀镍局部金 Nickel-Gold
 9=镀亮锡局部金 Half Gold-Tin Plating
 10=镀镍亮锡 Tin-Nickel Plating

表面处理
 Surface processing:

备注: 表面处理内容只在产品标签中体现!

其它料号说明 OTHER

P 0001 - B

P: Other Types

产品序号 Product Number

同型号序号 Same Series Different Type: B-Z (默认空)

927833端子承认书图面

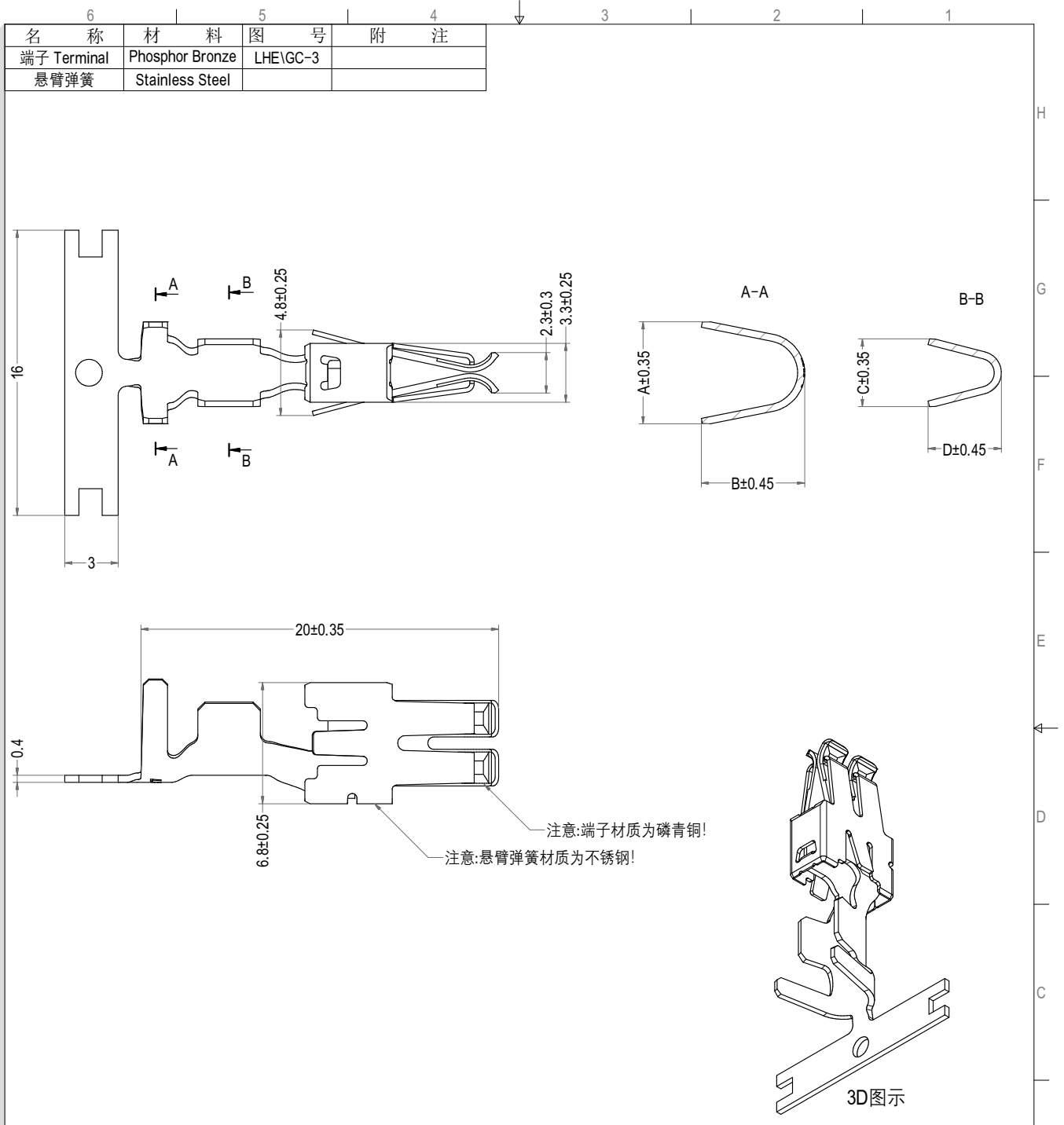

名称	材料	图号	附注
端子 Terminal	Phosphor Bronze	LHE\GC-3	
悬臂弹簧	Stainless Steel		

LHE® 浙江联和电子有限公司

品名	927833-2	比例	3:1
料号	C5001-TP	未注公差(mm)	
图号	LHE\GC-3	>0~3	±0.12
材料	Phosphor Bronze	>3~18	±0.15
制图	邱铭慧 2022-12-22	>18~50	±0.3
审核	陈浙海 2022-12-22	>50~120	±0.5
批准	李育文 2022-12-22	X°	±3°
视角		X.X°	±0.5°

Part No.	Description	A	B	C	D	Wire Range	Finish	Qty/reel
C5001-TP	927833-2	5.7	5.80	3.80	4.10	AWG #17 to #14	Tin	1,200pcs
C5001-T12P	927831-2	3.9	4.10	2.80	3.00	AWG #20 to #17	Tin	1,200pcs

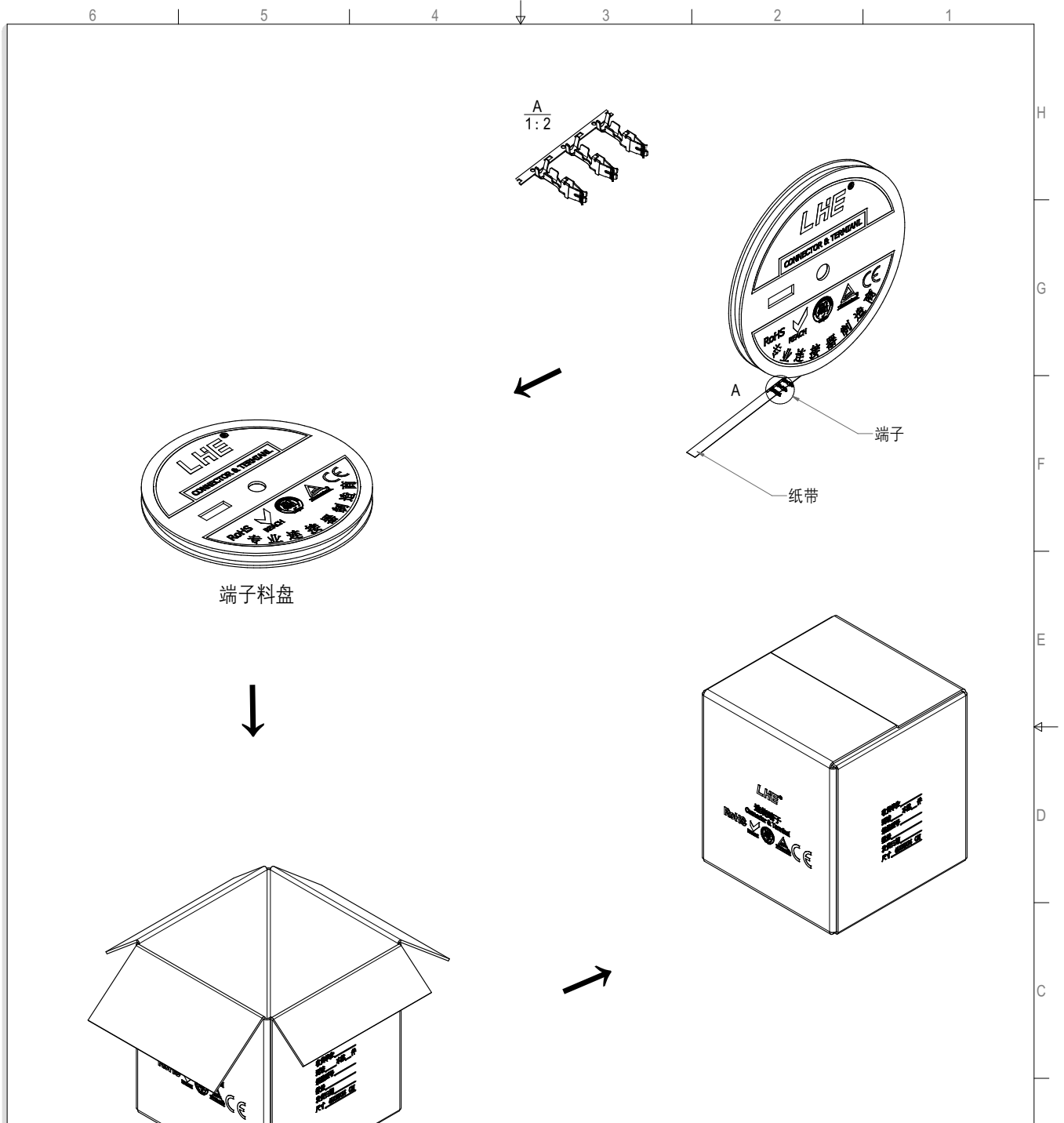

注释:

1. 产品尺寸请参照C5001-T图纸.
2. 此示意图为产品出料方式进行说明.
3. 胶带、PE袋未在图纸中体现,请以实物为准.

Part No.	Description	Qty/reel	Reel/caton
C5001-TP	927833-2	1200pcs	18/Reel
C5001-T12P	927831-2	1200pcs	18/Reel

LHE 浙江联和电子有限公司

品名	927833-2包装	比例	1:10
料号	C5001-TP包装	未注公差(mm)	
图号	LHE\GC-4	>0~3	±0.12
材料	/	>3~18	±0.15
制图	吴晓金 2023-07-21	>18~50	±0.3
审核	陈浙海 2023-07-21	>50~120	±0.5
批准	季育文 2023-07-21	X°	±3°
视角		X.X°	±0.5°

项目 Item	测试条件 Test Condition	规格要求 Requirement	
1. 压着部位抗拉强度 Crimping Pull Out Force	在试验装置夹头中固定测试样品, 在连接的轴线方向施加拉力; 速度不大于25mm/min。 Fix the crimped terminal, apply axial pull out force on the wire at the speed rate of not more 25mm/min.	AWG.14#	≥220N
		AWG.16#	≥130N
		AWG.18#	≥50N
		AWG.20#	≥40N
2. 壳体/端子固定力 Terminal/Housing Retention Force	固定连接器或测力计, 在连接器轴线方向施加规定的拉力; 速度不大于25mm/min。 Apply axial pull out force at the speed rate of not more 25mm/min on the pin assembled in the housing.	≥1.5N	
3. 针的固定力 Pin Retention Force	固定连接器或测力计, 在连接器轴线方向对针施加规定的推力; 速度不大于25mm/min。 Apply axial push out force at the speed rate of not more 25mm/minute on the terminal assembled in the base.	/	
4. 可焊性 Solderability	把测试样品需要焊接的部位浸入焊锡炉中 (锡炉温度245°C±5°C)2±0.5秒钟。 Soldering time: 2±0.5 sec Solder Temperature:245°C±5°C	上锡率≥90% 90% of immersed area must show no voids, pin holes	
5. 耐焊接热 Resistance to Soldering Heat	把测试样品需要焊接的部位浸入焊锡炉中(锡炉温度260°C); 2±0.5秒钟后, 在正常的条件下恢复1小时。 Soldering time: 2±0.5 sec Solder Temperature:260°C	外观 Appearance	无损伤 No Damage
6. 耐高温 Heat Resistance	连接器配合后, 于+110°C±2°C的空气中放置96小时, 然后再回到室温中放置1~2小时测定 Mated connectors are exposed to a temperature of +110°C±2°C for 96 hours.	外观 Appearance	无损伤 No Damage
7. 耐低温 Cold Resistance	连接器配合后, 于-40°C±2°C的空气中放置96小时, 然后再回到室温中放置1~2小时测定 Mated connectors are exposed to a temperature of -40°C±2°C for 96 hours.	接触电阻 Contact Resistance LLCR	≤20mΩ
8. 温度上升 Temperature Rise	插入连接器, 通以最大允许电流。 Carrying rated current load.	温度最大上升 Temperature Rise	≤30°C
9. 恒定湿热 Humidity	温度 Temperature: 40±2°C 相对湿度 Relative Humidity: 90%~95% 搁置时间 Duration: 96h, 取出恢复2小时后检查	外观 Appearance	无损伤 No Damage
10. 温度循环 Temperature cycle	把测试样品放入高低温试验箱中,按下列步骤调试温度: a)在-40°C±2°C的恒温条件下放置0.5小时; b)在+110°C±2°C的恒温条件下放置0.5小时; 从a)到b)为一个循环周期,共进行5个循环。恢复1h后检查。 状态转换时间不多于1小时。 Mated connectors are exposed to 5 cycles of: a)-40°C±2°C 0.5hour b)+110°C±2°C 0.5hour	耐电压 Dielectric Strength	3000V
		绝缘电阻 Insulation Resistance	≥500MΩ
11. 机械寿命 Repeated insertion/withdrawal	以每分钟插拔10次的速率, 插拔50次。 When mated up to 50 cycles repeatedly by the rate of 10 cycles per minute.	接触电阻 Contact Resistance LLCR	≤20mΩ
12. 机械振动 Vibration	插入连接器, 串联在一直流电源上, 电流100mA; 并模拟正常工作状态, 振频为10~55Hz、振幅1.5mm; 55~500Hz、加速度50m/s ² , 每一轴线扫频循环次数10次、2小时。 Frequency: 10~55Hz Amplitude: ±1.5mm Frequency: >55~500Hz Acceleration: 50m/s ² Duration: 2 hours in each X,Y,Z axes	外观 Appearance	无损伤 No Damage
		接触电阻 Contact Resistance LLCR	≤20mΩ
		中断 Intermittence	≤1μ sec

项目 Item	测试条件 Test Condition	规格要求 Requirement
13. 外观 Appearance	目测 Visual by eye 视力 Light: >1.0 照明 Lamp: 200~300Lx 目测距离 Space: 0.3~0.5m	1.塑料件表面应无明显疤痕、凹陷、开裂及影响使用的变形。 Plastic part:smooth and flat surface without discolor,broken,crack distortion defects is acceptable. 2.金属件表面无锈蚀、氧化、无明显的机械损伤等缺陷。 Metal part:btight and even surface without rust,oxide, fog and obvious physical damage defects is acceptable. 3.导线表面清洁、无破损等缺陷, 印字及标志清晰。 Wire:clearing surface without discolor,broken defects,indistinct words and mark is acceptable.
14. 盐雾 Salt Spray	把先冲后镀*的测试样品从试验箱顶悬挂下来, 采用浓度为5%±1(质量百分比)的氯化钠溶液, 连续雾化16小时, 试验后用流动的蒸馏水轻轻洗去表面沉积物。在常温常驻湿条件下恢复1~2小时。 16 hour exposure to a saltspray from the 5%±1 solution.	外观无损伤(五金件应无露出底金属的严重锈蚀; 使用预镀的型材, 其落料面允许有不影响其性能的轻微腐蚀。) Appearance:No Damage(No erosion with material exposed.And with plating material, slight erosion on the cutting surface acceptable)
15. 接触电阻 Contact Resistance	插合连接器,用小功率电路进行测试。 Mate connectors,measure by dry circuit.	≤10mΩ (Initial value)
16. 绝缘电阻 Insulation Resistance	在相邻接触件之间或地线之间, 用500V DC电压进行测试。 Apply 500V DC between adjacent terminal or ground.	≥500MΩ
17. 耐电压 Dielectric Strength	相邻接触件之间或地线之间施加50Hz 3000V AC(有效值), 漏电流1mA的电压作用, 时间1min。 Mate connectors, apply 3000V AC for 1 minute between adjacent terminal or ground.	无击穿和飞弧现象 No Breakdown
18. 插入力与拔出力 Insertion and Withdrawal Force	单PIN相配的接触器以1mm/s~5mm/s的速度沿接插器轴线方向插入和拔出。 Insertion and withdraw single contact at the speed rate of 1mm/s~5mm/s.	极数 Poles
	相配的连接器以1mm/s~5mm/s的速度沿接插器轴线方向插入和拔出。 Insertion and withdraw connectors at the speed rate of 1mm/s~5mm/s.	插入力(最大值N) Insertion(N Max) 1st 拔出力(最小值N) Withdrawal(N Min) 1st

* 先冲后镀为定制端子。常规端子为先镀后冲, 无法通过盐雾试验。

制订 Edit: 邱铭慧

日期 DATE: 2022-12-22

审核 Check: 陈浙海

日期 DATE: 2022-12-22

批准 Approval: 季育文

日期 DATE: 2022-12-22

UL Product iQ[™]

ECBT2.E364711 - Connectors for Use in Data, Signal, Control and Power Applications - Component

Connectors for Use in Data, Signal, Control and Power Applications - Component

See General Information for Connectors for Use in Data, Signal, Control and Power Applications - Component

ZHEJIANG LIANHE ELECTRONIC CO LTD

E364711

Chuangxin Road, YueQing Bay Port Zone
Yueqing, Zhejiang 325600 CHINA

Connector, Model(s) 1.58-LHE f/b 2 , f/b 1 thru 12, f/b A2 or AW., 1.58-LHE f/b 2 thru 6, f/b A2 or AW

Connector, Model(s) 1.58-LHE followed by 2, followed by 1 thru 12, followed by A(T).

Connector, Model(s) 1.58-LHE, f/b 2 thru 6, f/b A(T), 1.58-LHE, f/b 2 thru 6, f/b Y(T), 1.58-LHE, f/b 2, f/b 1 thru 12, f/b Y(T), 2510-LHE f/b 2, f/b 1 thru 12, f/b A2 or AW, 2510-LHE f/b 2 thru 6, f/b A2 or AW

Connector, Model(s) 2510-LHE followed by 2, followed by 1 thru 12, followed by A(T)

Connector, Model(s) 2510-LHE, f/b 2 thru 6, f/b A(T), 2510-LHE, f/b 2 thru 6, f/b Y(T), 2510-LHE, f/b 2, f/b 1 thru 12, f/b Y(T), 5.08-LHE f/b 2, f/b 1 thru 12, f/b A2 or AW, 5.08-LHE f/b 2 thru 6, f/b A2 or AW

Connector, Model(s) 5.08-LHE followed by 2, followed by 1 thru 12, followed by A(T)

Connector, Model(s) 5.08-LHE, f/b 2 thru 6, f/b A(T), 5.08-LHE, f/b 2 thru 6, f/b Y(T), 5.08-LHE, f/b 2, f/b 1 thru 12, f/b Y(T), 51005-LHE f/b 2, f/b 1 thru 12, f/b A2 or AW, 51005-LHE f/b 2 thru 6, f/b A2 or AW

Connector, Model(s) 51005-LHE followed by 2, followed by 1 thru 12, followed by A(T)

Connector, Model(s) 51005-LHE, f/b 2 thru 6, f/b A(T), 51005-LHE, f/b 2 thru 6, f/b Y(T), 51005-LHE, f/b 2, f/b 1 thru 12, f/b Y(T), 51006-LHE f/b 2, f/b 1 thru 12, f/b A2 or AW, 51006-LHE f/b 2 thru 6, f/b A2 or AW

Connector, Model(s) 51006-LHE followed by 2, followed by 1 thru 12, followed by A(T)

Connector, Model(s) 51006-LHE, f/b 2 thru 6, f/b A(T), 51006-LHE, f/b 2 thru 6, f/b Y(T), 51006-LHE, f/b 2, f/b 1 thru 12, f/b Y(T), 5102-LHE f/b 2, f/b 1 thru 12, f/b A2 or AW, 5102-LHE f/b 2 thru 6, f/b A2 or AW

Connector, Model(s) 5102-LHE followed by 2, followed by 1 thru 12, followed by A(T)

Connector, Model(s) 5102-LHE, f/b 2 thru 6, f/b A(T), 5102-LHE, f/b 2 thru 6, f/b Y(T), 5102-LHE, f/b 2, f/b 1 thru 12, f/b Y(T), 5240-LHE f/b 2, f/b 1 thru 12, f/b A2 or AW, 5240-LHE f/b 2 thru 6, f/b A2 or AW

Connector, Model(s) 5240-LHE followed by 2, followed by 1 thru 12, followed by A(T)

Connector, Model(s) 5240-LHE, f/b 2 thru 6, f/b A(T), 5240-LHE, f/b 2 thru 6, f/b Y(T), 5240-LHE, f/b 2, f/b 1 thru 12, f/b Y(T), 5500-LHE f/b 2, f/b 1 thru 12, f/b A2 or AW, 5500-LHE f/b 2 thru 6, f/b A2 or AW

Connector, Model(s) 5500-LHE followed by 2, followed by 1 thru 12, followed by A(T)

Connector, Model(s) 5500-LHE, f/b 2 thru 6, f/b A(T), 5500-LHE, f/b 2 thru 6, f/b Y(T), 5500-LHE, f/b 2, f/b 1 thru 12, f/b Y(T), 5557 followed by 2 thru 6, followed by A(T), 5557 followed by 2 thru 6, followed by A2 or AW, 5557 followed by 2 thru 6, followed by Y(T)

Connector, Model(s) 5557 followed by 2, followed by 1 thru 12, followed by A(T).

- Connector**, Model(s) 5557 followed by 2, followed by 1 thru 12, followed by A2 or AW
- Connector**, Model(s) 5557 followed by 2, followed by 1 thru 12, followed by Y(T)
- Connector**, Model(s) 5559-LHE f/b 2 , f/b 1 thru 12, f/b A2 or AW, 5559-LHE f/b 2 thru 6, f/b A2 or AW
- Connector**, Model(s) 5559-LHE followed by 2, followed by 1 thru 12, followed by A(T).
- Connector**, Model(s) 5559-LHE, f/b 2 thru 6 , f/b A(T), 5559-LHE, f/b 2 thru 6, f/b Y(T), 5559-LHE, f/b 2, f/b 1 thru 12 , f/b Y(T), 5566-LHE f/b 2 , f/b 1 thru 12, f/b A2 or AW, 5566-LHE f/b 2 thru 6, f/b A2 or AW
- Connector**, Model(s) 5566-LHE followed by 2, followed by 1 thru 12, followed by A(T)
- Connector**, Model(s) 5566-LHE, f/b 2 thru 6 , f/b A(T), 5566-LHE, f/b 2 thru 6, f/b Y(T), 5566-LHE, f/b 2, f/b 1 thru 12 , f/b Y(T), 5569-LHE f/b 2 , f/b 1 thru 12, f/b A2 or AW, 5569-LHE f/b 2 thru 6, f/b A2 or AW
- Connector**, Model(s) 5569-LHE followed by 2, followed by 1 thru 12, followed by A(T)
- Connector**, Model(s) 5569-LHE, f/b 2 thru 6 , f/b A(T), 5569-LHE, f/b 2 thru 6, f/b Y(T), 5569-LHE, f/b 2, f/b 1 thru 12 , f/b Y(T), 5600-LHE f/b 2 , f/b 1 thru 12, f/b A2 or AW, 5600-LHE f/b 2 thru 6, f/b A2 or AW
- Connector**, Model(s) 5600-LHE followed by 2, followed by 1 thru 12, followed by A(T)
- Connector**, Model(s) 5600-LHE, f/b 2 thru 6 , f/b A(T), 5600-LHE, f/b 2 thru 6, f/b Y(T), 5600-LHE, f/b 2, f/b 1 thru 12 , f/b Y(T), 63080-LHE f/b 2 , f/b 1 thru 12, f/b A2 or AW, 63080-LHE f/b 2 thru 6, f/b A2 or AW
- Connector**, Model(s) 63080-LHE followed by 2, followed by 1 thru 12, followed by A(T)
- Connector**, Model(s) 63080-LHE, f/b 2 thru 6 , f/b A(T), 63080-LHE, f/b 2 thru 6, f/b Y(T), 63080-LHE, f/b 2, f/b 1 thru 12 , f/b Y(T), B2502 followed by 2 thru 16, followed by Y(T), BH3.5-2A(T), BH3.5-2Y(T), MX3.0 followed by 2 thru 12, followed by A(T), MX3.0 followed by 2 thru 12, followed by A2 or AW, MX3.0 followed by 2 thru 12, followed by Y(T)
- Connector**, Model(s) MX3.0 followed by 2, followed by 1 thru 12, followed by A(T).
- Connector**, Model(s) MX3.0 followed by 2, followed by 1 thru 12, followed by A2 or AW
- Connector**, Model(s) MX3.0 followed by 2, followed by 1 thru 12, followed by Y(T)
- Connector**, Model(s) PA-LHE f/b 2, f/b 1 thru 12, f/b Y(T), PA-LHE followed by 2 thru 12, followed by A(T)
- Connector**, Model(s) PA-LHE followed by 2 thru 12, followed by A2 or AW
- Connector**, Model(s) PA-LHE followed by 2 thru 12, followed by Y(T)
- Connector**, Model(s) PA-LHE followed by 2, followed by 1 thru 12, followed by A(T)
- Connector**, Model(s) PA-LHE followed by 2, followed by 1 thru 12, followed by A2 or AW
- Connector**, Model(s) PH, PHB, XHB, JC25, SCN followed by -2 thru -20, followed by Y(T), A, AW or AWD
- Connector**, Model(s) PHB followed by 2 thru 16, followed by Y(T). followed by 2 thru 16, followed by AWD, A, AW
- Connector**, Model(s) Series 1.25, 1254, 1255 followed by -2 thru -25, followed by Y(T), A or AW
- Connector**, Model(s) Series 5264 followed by -2 thru -16, followed by Y(T), A or AWD
- Connector**, Model(s) SM followed by -2 thru -18, followed by Y(T) or A(T)
- Connector**, Model(s) VH, 3.96 followed by -2 thru -16, followed by Y(T), A, AW or AWG
- Connector**, Model(s) XA-LHE f/b 2, f/b 1 thru 12, f/b Y(T), XA-LHE followed by 2 thru 12, followed by A(T)
- Connector**, Model(s) XA-LHE followed by 2 thru 12, followed by A2 or AW
- Connector**, Model(s) XA-LHE followed by 2 thru 12, followed by Y(T)
- Connector**, Model(s) XA-LHE followed by 2, followed by 1 thru 12, followed by A(T)
- Connector**, Model(s) XA-LHE followed by 2, followed by 1 thru 12, followed by A2 or AW
- Connector**, Model(s) XH followed by -2 thru -20, followed by Y(T), A, AW, AWGD, AWD or AWGDJ
- Connector**, Model(s) ZH followed by 2 thru 16, followed by AWD or A, ZH followed by 2 thru 16, followed by Y(T).

Model(s) 1.25, followed by -2 thru -16, followed by AB or AWB

Model(s) 51146 or FI-S, followed by -2 thru -16, followed by AB or AWB

Model(s) A5001, followed by -2 thru -7, followed by Y, Y(T), AD or AWD

Model(s) B2501-LHE, A2004-LHE, A4203-LHE, PHR-LHE, PHD-LHE, CH2.5-LHE, DF11-LHE, PHSD-LHE, A5001-LHE, 35155-LHE, 35156-LHE, 5195-LHE, 5196-LHE, followed by 2 thru 16, followed by Y(T)

Model(s) BHS-LHE, SMH250-LHE, SMH200-LHE, L6.2-LHE, 1806-LHE, 2060-LHE, 2541-LHE, JC15-LHE, XHD-LHE, followed by -2, followed by A(T), or Y(T)

Model(s) JWPf-LHE, B2541-LHE, NV-LHE, DV-LHE, SGN-LHE, SJN-LHE, SDN-LHE, SIN-LHE, 35150-LHE, 35151-LHE, 35180-LHE, 35182-LHE, 35524-LHE, 35965-LHE, RCY-LHE, LC-LHE, VR-LHE, SHJ-LHE, SHL-LHE, DF19-LHE, ACH-LHE, DF13-LHE, IL-Z-LHE, 51146-LHE, SATA-LHE, XSR-LHE, SUR-LHE, SUH-LHE, ZE-LHE, ZND-LHE, ZPD-LHE, A1502-LHE, SFH-LHE, 51004-LHE, PUD-LHE, A20010-LHE, 35507-LHE, DF3-LHE, PND-LHE, RE-LHE, RA-LHE, RF-LHE or A3963, followed by -2 thru -15, followed by Y(T), YB(T) or YC(T), A, A-K, AW, AW-K, AD, AD-K, AWGD, AWGD-K, AQ, AQ-K, AWQ, AWQ-K, AD(BH) or AD(BH)-K.

Model(s) PH, followed by -2 thru -16, followed by AB or AWB

Model(s) PHB, SZN-LHE, SAN-LHE, JC20-LHE, EH-LHE, EI-LHE, EL-LHE, S-EL-LHE, followed by 2 thru 16, followed by AWD, A, AW

Model(s) PHB, SZN-LHE, SAN-LHE, JC20-LHE, EH-LHE, EI-LHE, EL-LHE, S-EL-LHE, followed by 2 thru 16, followed by Y(T)

Model(s) PHB, XH, XHB or XHBD, followed by -2 thru -16, followed by AB or AWB.

Model(s) RAST 5-LHE TAB HEADER ASSY , TH, Vertical, Cat. Nos. 1969738-LHE, 1969740-LHE, 1971845-LHE, 1971846-LHE, 1971895-LHE, 1971896-LHE, 1971946-LHE thru 1971949-LHE, 1971954-LHE thru 1971957-LHE, 2232008-LHE thru 2232011-LHE, 2232000-LHE thru 2232003-LHE, 2232016-LHE thru 2232019-LHE, 1971962-LHE thru 1971965-LHE, 2232024-LHE thru 2232027-LHE, 2232289-LHE thru 2232292-LHE, 2232043-LHE thru 2232074-LHE, 2232298-LHE thru 2232301-LHE, 2232511-LHE, 2232532-LHE, 2232557-LHE, 2232559-LHE, 2232560-LHE, 2232562-LHE, 2232563-LHE, 2232565-LHE, 2232566-LHE, 2232568-LHE, 2232569-LHE, 2232571-LHE, 2232572-LHE, 2232574-LHE, 2232575-LHE, 2232577-LHE, 2232578-LHE, 2232580-LHE, 2232581-LHE, 2232583-LHE, 2232584-LHE, 2232586-LHE, 2232587-LHE, 2232589-LHE, 2232590-LHE, 2232592-LHE, 2232593-LHE, 2232595-LHE, 2232596-LHE, 2232598-LHE, 2232599-LHE, 2232601-LHE, 2232602-LHE, 2232604-LHE, 2232605-LHE, 2232607-LHE, 2232608-LHE, 2232611-LHE thru 2232682-LHE, 2292457-LHE, 2292458-LHE, may incorporate prefix and/or suffix number.), followed by -2 thru -7, followed by Y, Y(T), AD or AWD.

Model(s) SY, followed by -2, followed by Y, Y(T), A or A(T)

Model(s) SYP, SYR, BH4.0-LHE, A10001-LHE, A7501-LHE, A8001-LHE, C2541-LHE, C2542-LHE, D250R-LHE, D280K-LHE, D300R-LHE, D350R-LHE, D400B-LHE, D430R-LHE, D470G-LHE, D480J-LHE, D480K-LHE, D480N-LHE, D480Q-LHE, D520H-LHE, D520K-LHE, D520Q-LHE, D620G-LHE, D630J-LHE, D630N-LHE, D630Q-LHE, D700G-LHE, F001-LHE, F002-LHE, HIF3-LHE, MC100-LHE, MC100-LHE, ME020-LHE, ME010-LHE, F2541-LHE, D2301-LHE, 1719057-LHE, 1719059-1-LHE, P0011-LHE, P0012-LHE, P0013-LHE, C6001-LHE, D2201-LHE, D2202-LHE or P0001-LHE, followed by -2, followed by Y, Y(T), A or A(T).

Model(s) VL-LHE , YL-LHE, SL-LHE, FL-LHE, YHD200-LHE, HA-LHE, LGC-LHE, JR-LHE, SP-LHE, 5025-LHE, followed by 2, followed by 1 thru 12, followed by A(T), Y(T), A2 or AW



Model(s) VL-LHE, YL-LHE, SL-LHE, FL-LHE, YHD200-LHE, HA-LHE, LGC-LHE, JR-LHE, SP-LHE, 5025-LHE, followed by 2 thru 12, followed by A(T), Y(T), A2 or AW

Model(s) XHD, XHE or XHQ, followed by -2 thru -15, followed by Y(T), YB(T) or YC(T), A, A-K, AW, AW-K, AD, AD-K, AWGD, AWGD-K, AQ, AQ-K, AWQ, AWQ-K, AD(BH) or AD(BH)-K.

Model(s) ZH, followed by -2 thru -16, followed by AB or AWB

Model(s) ZHR-LHE, SH-LHE, GH-LHE, NH-LHE, C1251-LHE, DF14-LHE, 5501-LHE, 75416-LHE, 543-LHE, followed by 2 thru 16, followed by AWD or A

Model(s) ZHR-LHE, SH-LHE, GH-LHE, NH-LHE, C1251-LHE, DF14-LHE, 5501-LHE, 75416-LHE, 543-LHE, followed by 2 thru 16, followed by Y(T)

Marking: Company name or trademark  , model designation and the Recognized Component Mark,  on the device or carton.

Last Updated on 2020-02-20

并不是所有出现在本数据库中的公司名称和产品都满足了UL 跟踪检验服务的要求。只有带有 UL 标志的产品，才应该被视为经过 UL 认证，并满足UL 跟踪检验服务的要求。注意查看产品上的标志。

UL 允许在线认证目录中所含材料的复制遵循以下条件：1.指南信息、装配、构造、设计、系统和/或认证（文件）必须在不篡改任何数据（或图纸）的情况下完整且无误导性地呈现。2.“经 UL 允许从在线认证目录转载”声明必须出现在所摘取材料的邻近位置。此外，转载材料必须包含以下格式的版权声明：“© 2020 UL LLC”

 PRODUCT CERTIFICATION	
CERTIFICATE NO.: CQC17134174484	Valid from: Jan.20,2021 Valid until: Aug.31,2025
NAME AND REGISTERED ADDRESS OF THE APPLICANT	Zhejiang Lianhe Electronics Co., Ltd. Yueshang Pioneer Park,Yueqingwan Area, Yueqing City, Zhejiang Province
NAME AND REGISTERED ADDRESS OF THE MANUFACTURER	Zhejiang Lianhe Electronics Co., Ltd. Yueshang Pioneer Park,Yueqingwan Area, Yueqing City, Zhejiang Province
NAME AND LOCATION OF THE FACTORY	Zhejiang Lianhe Electronics Co., Ltd. No. 8, Chuangxin Road, Yueqing Bay Port District, Yueqing City, Zhejiang Province
PRODUCT NAME, MODEL AND SPECIFICATION	Connector (PA66) See Annex , Material name: PA66, material grade: A3RV0, All color, Ball pressure:200°C, Glow-Wire Flammability Index(GWFI): 960/0.3, Glow-Wire Ignition Temperature(GWIT):960/0.3, Flammability:V-0@0.3mm, CTI600 , Infrared Analysis,Differential Scanning Calorimetry(DSC), Thermogravimetry (TG) to see report Ref.No: 00501-2020134003037
THE STANDARDS AND TECHNICAL REQUIREMENTS FOR THE PRODUCTS	GB/T 5169.21-2017, GB/T 5169.12-2013, GB/T 5169.13-2013, GB/T 5169.16-2017, GB/T 4207-2012, GB/T 6040-2019, GB/T 19466.1-2004, GB/T 19466.2-2004, GB/T 19466.3-2004, ISO 11358-1:2014
TYPE OF CERTIFICATION SCHEMES	Product Testing + Follow up Factory Inspection
<p>This is to certify that the above mentioned product(s) complies with the requirements of certification rules of CQC13-036047-2009. The validity of the certificate is subject to positive result of the regular follow up inspection by issuing certification body until the expiry date.</p>	
<p>The certificate information is available through the QR code below or CNCA's website: www.cnca.gov.cn</p>	
	
SIGNATURE:	
CHINA QUALITY CERTIFICATION CENTRE	
	
http://www.cqc.com.cn	Section 9, No.188, Nanshuan Xilu, Beijing 100070 P.R.China
Tel: +86 10 83886666	

C 0453132

ZERTIFIKAT ■ CERTIFICATE ■ CERTIFICADO ■ CERTIFICAT

Verification No.: CLZJ1411264692



VERIFICATION OF LVD COMPLIANCE

Applicant: Zhejiang Lianhe Electrical Co., Ltd.
 Houyu village, Shifan town, Yueqing city, Zhejiang province, China.

Manufacturer: Same as applicant

Product Description: Connector Terminal

Model No: A1001, A1002, A1003, A1251, A1252, A1253, A1254, A1255, A1256, A1257, A1501, A1502, A1503, A2001, A2002, A2003, A2004, A2005, A2006, A2007, A2501, A2502, A2503, A2504, A2505, A2506, A2507, A2541, A2542, A2543, A2544, A2545, A3961, A3962, A3963, A3564, A5081, A5082, B1501, B1502, B2001, B2002, B2501, B2502, C01581, C01582, C1251, C2001, C2002, C2501, C2502, C2505, C2506, C3001, C3002, C3003, C3004, C3005, C3006, C3501, C3502, C3701, C3702, C4001, C4002, C4141, C4142, C4201, C4202, C4203, C4204, C4601, C4602, C4501, C4502, C4503, C4504, C5001, C5002, C5031, C5032, C6201, C6202, C6351, C6352, C6701, C6702, D2801, D2802, D2803, D4801, D4802, D4803, D4804, D6301, D6302, D6303

Sufficient samples of the product have been tested and found to be in conformity with
Test Standard: EN 60320-1:2001/A1:2007
 EN 60529:1991/A1:2000

As shown in the
Test Report Number(s): TLZJ1411264692
Date of issue: November 27, 2014

Conclusion

This Verification of LVD Compliance has been granted to the applicant based on the results of tests, performed by laboratory of Global Testing Services Co., Ltd on sample of the above-mentioned product in accordance with the provisions of the relevant specific standards and the Low Voltage Directive 2014/35/EU. The CE marking as shown below can be affixed, under the responsibility of the manufacturer, after completion of an EC Declaration of Conformity and compliance with all relevant EC Directives. The affixing of the CE marking presumes in addition that conditions the conditions in annexes III and IV of the Directive are fulfilled.

Approved by: Hermann Weiher

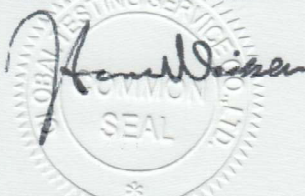

Global Testing Services Co., Ltd
 E-mail: info@gts-lab.com <http://www.gts-lab.com>
 Room 1501-1502, No. 520 Yishan Rd., Xuhui District, Shanghai, 200235 China



For and on behalf of
 Global Testing Services Co., Ltd



Copyright of this certificate is owned by Global Testing Services Co., Ltd and may not be reproduced other than in full and with the prior approval of the General Manager.



产品认证证书

证书编号: CQC17134174484

发证日期: 2021年01月20日

有效期至: 2025年08月31日

委托人名称 浙江联和电子有限公司
及注册地址 浙江省乐清市乐清湾港区乐商创业园

制造商名称 浙江联和电子有限公司
及注册地址 浙江省乐清市乐清湾港区乐商创业园

生产企业名称 浙江联和电子有限公司
及生产地址 浙江省乐清市乐清湾港区创新路8号

产品名称和系列、规格、型号 连接器聚酰胺 66(PA66)
 型号见附件, 材料名称: 聚酰胺 (PA66), 材料牌号: A3RV0, 全色, 球压:200°C, 灼热丝可燃性指数(GWFI):960/0.3, 灼热丝起燃温度(GWIT):960/0.3, 燃烧等级:V-0@0.3mm,CTI600, 红外光谱,差示扫描量热和热重分析见报告 00601-2020134003037

产品标准和技术要求 GB/T 5169.21-2017, GB/T 5169.12-2013, GB/T 5169.13-2013, GB/T 5169.16-2017, GB/T 4207-2012, GB/T 6040-2019, GB/T 19466.1-2004, GB/T 19466.2-2004, GB/T 19466.3-2004, ISO 11358-1:2014

认证模式 产品检测+获证后监督

上述产品符合 CQC13-036047-2009 认证规则的要求, 特发此证。
 证书有效期内本证书的有效性依据发证机构的定期监督获得保持。

可通过扫描下方二维码或登录国家认监委网站 (www.cnca.gov.cn) 查验证书信息



签发: 陆杨

中国质量认证中心



<http://www.cqc.com.cn>

中国·北京·南四环西路188号9区 100070

电话: +86 10 83886666

C 0453132



THE INTERNATIONAL CERTIFICATION NETWORK

CERTIFICATE

CQC has issued an IQNet recognized certificate that the organization:
ZheJiang Lianhe Electronics Co.,Ltd.

Registered Address: Yueqing Bay Port Area, Yueqing City, Wenzhou City, Zhejiang Province, P.R.China
 Operation Address: No.8 Innovation Road, Yueqing Bay Port Area, Yueqing City, Wenzhou City, Zhejiang Province, P.R.China

has implemented and maintains an
Environmental Management System

for the following scope:

Design and Production of Connector and Related Management Activities

which fulfils the requirements of the following standard:

GBT 24001-2016 / ISO 14001:2015

Issued on: February 12, 2020

Expires on: February 11, 2023

Registration Number: **CN00120E30414R0S/3302**

This attestation is directly linked to the IQNet Partner's original certificate and shall not be used as a stand-alone document



Alex Stoichitoiu
 President of IQNet

Lu Mei
 President of CQC



IQNet Partners*:

- AENOR Spain AFNOR Certification France APCER Portugal CCC Cyprus CISQ Italy
- CQC China CQM China CQS Czech Republic Cro Cert Croatia DQS Holding GmbH Germany EAGLE Certification Group USA
- FCAV Brazil FONDONORMA Venezuela ICONTEC Colombia Inspecta Sertifiointi Oy Finland INTECO Costa Rica
- IRAM Argentina JQA Japan KFQ Korea MIRTEC Greece MSZT Hungary Nemko AS Norway NSAI Ireland
- NYCE-SIGE Mexico PCBC Poland Quality Austria Austria RR Russia SII Israel SIQ Slovenia
- SIRIM QAS International Malaysia SQS Switzerland SRAC Romania TEST St Petersburg Russia TSE Turkey YUQS Serbia

* The list of IQNet partners is valid at the time of issue of this certificate. Updated information is available under www.iqnet-certification.com

SGS

检测报告

编号: SHAEC23005417604

日期: 2023年05月09日

第1页, 共7页

客户名称: 浙江联和电子有限公司
客户地址: 浙江省乐清市乐清湾港区乐商创业园
浙江省乐清市乐清湾港区电子信息产业园红旗路8号

样品名称: 端子针
客户参考信息: 见附件
以上样品及信息由客户提供。

SGS工作编号: SHP23-001324
样品接收时间: 2023年05月04日
检测周期: 2023年05月04日~2023年05月09日
检测要求: 根据客户要求检测。
检测方法: 见后续页。
检测结果: 见后续页。

检测要求	结论
欧盟 RoHS 指令 2011/65/EU 附录 II 的修正指令(EU) 2015/863-铅、汞、镉和六价格	符合

通标准技术服务(上海)有限公司
授权签名

Jenny Lan 兰柳珍
批准签署人

scan to see the report



B6F28BB6



Unless otherwise agreed in writing, this document is issued by the Company subject to its General Conditions of Service printed overleaf, available on request or accessible at <http://www.sgs.com/en/Terms-and-Conditions.aspx> and, for electronic format documents, subject to Terms and Conditions for Electronic Documents at <http://www.sgs.com/en/Terms-and-Conditions/Terms-e-Documents.aspx>. Attention is drawn to the limitation of liability, indemnification and jurisdiction issues defined therein. Any holder of this document is advised that information contained hereon reflects the Company's findings at the time of its intervention only and within the limits of Client's instructions, if any. The Company's sole responsibility is to its Client and this document does not exonerate parties to a transaction from exercising all their rights and obligations under the transaction documents. This document cannot be reproduced except in full, without prior written approval of the Company. Any unauthorized alteration, forgery or falsification of the content or appearance of this document is unlawful and offenders may be prosecuted to the fullest extent of the law. Unless otherwise stated the results shown in this test report refer only to the sample(s) tested.

Attention: To check the authenticity of testing/inspection report & certificate, please contact us at telephone: (86-755) 8307 1443, or email: CN.Doccheck@sgs.com
3rd Building, No. 889 Yishan Road Xuhui District, Shanghai China 200233 t E&E (86-21) 61402553 f E&E (86-21) 64953679 www.sgs.com
中国·上海·徐汇区宜山路889号3号楼 邮编: 200233 t HL (86-21) 61402594 f HL (86-21) 61156899 e sgs.china@sgs.com

Member of the SGS Group (SGS SA)

Page 1 of 7



检测报告

编号: SHAEC23005417604

日期: 2023年05月09日

第2页, 共7页

检测结果:

检测部件外观描述:

样品序号	样品编号	SGS 样品 ID	样品描述
SN1	A2	SHA23-0054176-0001.C002	银色金属

备注:

- (1) 1 mg/kg = 1 ppm = 0.0001%
- (2) MDL= 方法检测限
- (3) ND = 未检出 (< MDL)
- (4) "-" = 未规定

欧盟 RoHS 指令 2011/65/EU 附录 II 的修正指令(EU) 2015/863-铅、汞、镉和六价铬

检测方法: 参考 IEC 62321-4:2013+AMD1:2017, IEC 62321-5:2013 和 IEC 62321-7-1:2015, 采用 ICP-OES 和 UV-Vis 进行分析。

检测项目	限值	单位	MDL	A2
镉 (Cd)	100	mg/kg	2	ND
铅 (Pb)	1000	mg/kg	2	71
汞 (Hg)	1000	mg/kg	2	ND
六价铬(Cr(VI))▼	-	µg/cm ²	0.10	ND

备注:

- (1) 最大允许限值引用自RoHS指令(EU) 2015/863。
- (2) IEC 62321系列等同于 EN 62321系列。
- (3) ▼ = a. 当六价铬的浓度高于0.13 µg/cm²时, 样品为阳性, 即含有六价铬;
b. 当六价铬的浓度为ND (低于0.10 µg/cm²) 时, 样品为阴性, 即未检测到六价铬;
c. 当六价铬的浓度介于0.10 µg/cm²与0.13 µg/cm²之间时, 无法直接判定是否检测到六价铬, 因不同个体的样品表面差异可能会影响测定结果。

由于未获知样品的存储条件和生产日期, 样品的六价铬检测结果仅能代表测试时样品含六价铬的状态。

除非另有说明, 参照 ILAC-G8:09/2019, 使用简单接受 (w=0) 的二元判定规则进行符合性判定。

除非另有说明, 此报告结果仅对检测的样品负责。本报告未经本公司书面许可, 不可部分复制。

检测报告仅用于客户科研、教学、内部质量控制、产品研发等目的, 仅供内部参考。



Unless otherwise agreed in writing, this document is issued by the Company subject to its General Conditions of Service printed overleaf, available on request or accessible at <http://www.sgs.com/en/Terms-and-Conditions.aspx> and, for electronic format documents, subject to Terms and Conditions for Electronic Documents at <http://www.sgs.com/en/Terms-and-Conditions/Terms-e-Documents.aspx>. Attention is drawn to the limitation of liability, indemnification and jurisdiction issues defined therein. Any holder of this document is advised that information contained hereon reflects the Company's findings at the time of its intervention only and within the limits of Client's instructions, if any. The Company's sole responsibility is to its Client and this document does not exonerate parties to a transaction from exercising all their rights and obligations under the transaction documents. This document cannot be reproduced except in full, without prior written approval of the Company. Any unauthorized alteration, forgery or falsification of the content or appearance of this document is unlawful and offenders may be prosecuted to the fullest extent of the law. Unless otherwise stated the results shown in this test report refer only to the sample(s) tested.
Attention: To check the authenticity of testing/inspection report & certificate, please contact us at telephone: (86-755) 8307 1443, or email: CN.Doccheck@sgs.com
3rd Building, No.889 Yishan Road Xuhui District, Shanghai China 200233 | E&E (86-21) 61402553 | E&E (86-21) 64953679 | www.sgs.com.cn
中国·上海·徐汇区宜山路889号3号楼 邮编: 200233 | TL (86-21) 61402594 | TL (86-21) 61156899 | e sgs.china@sgs.com

Member of the SGS Group (SGS SA)

Page 2 of 7



检测报告

编号: SHAEC23005417604

日期: 2023年05月09日

第3页, 共7页

附件

元素检测流程图

样品按照下述流程被完全消解

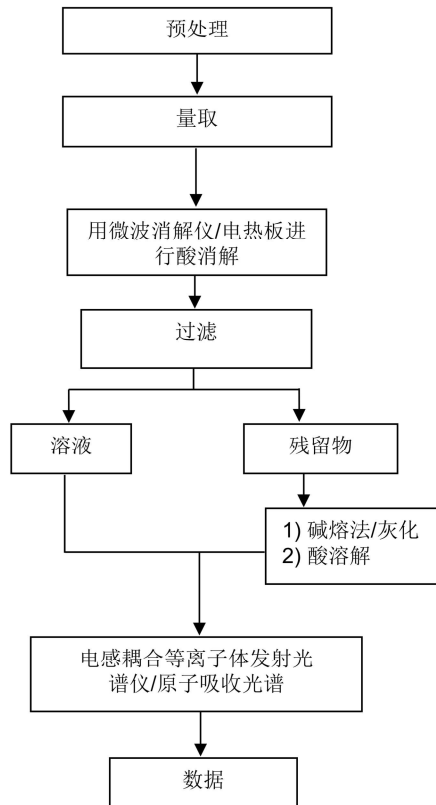

Unless otherwise agreed in writing, this document is issued by the Company subject to its General Conditions of Service printed overleaf, available on request or accessible at <http://www.sgs.com/en/Terms-and-Conditions.aspx> and, for electronic format documents, subject to Terms and Conditions for Electronic Documents at <http://www.sgs.com/en/Terms-and-Conditions/Terms-e-Documents.aspx>. Attention is drawn to the limitation of liability, indemnification and jurisdiction issues defined therein. Any holder of this document is advised that information contained hereon reflects the Company's findings at the time of its intervention only and within the limits of Client's instructions, if any. The Company's sole responsibility is to its Client and this document does not exonerate parties to a transaction from exercising all their rights and obligations under the transaction documents. This document cannot be reproduced except in full, without prior written approval of the Company. Any unauthorized alteration, forgery or falsification of the content or appearance of this document is unlawful and offenders may be prosecuted to the fullest extent of the law. Unless otherwise stated the results shown in this report refer only to the sample(s) tested.

Attention: To check the authenticity of testing/inspection report & certificate, please contact us at telephone: (86-755) 8307 1443, or email: CN.Doccheck@sgs.com

SGS-CSTC (Shanghai) Technical Services Co., Ltd. 3rd Building, No. 889 Yehuan Road Xuhui District, Shanghai China 200233 t E&E (86-21) 61402553 f E&E (86-21) 64053679 www.sgs.com.cn
 中国·上海·徐汇区宜山路889号3号楼 邮编: 200233 t HL (86-21) 61402594 f HL (86-21) 61156899 e sgs.china@sgs.com

Member of the SGS Group (SGS SA)



检测报告
附件

编号: SHAEC23005417604

日期: 2023年05月09日

第4页, 共7页

六价铬检测流程图

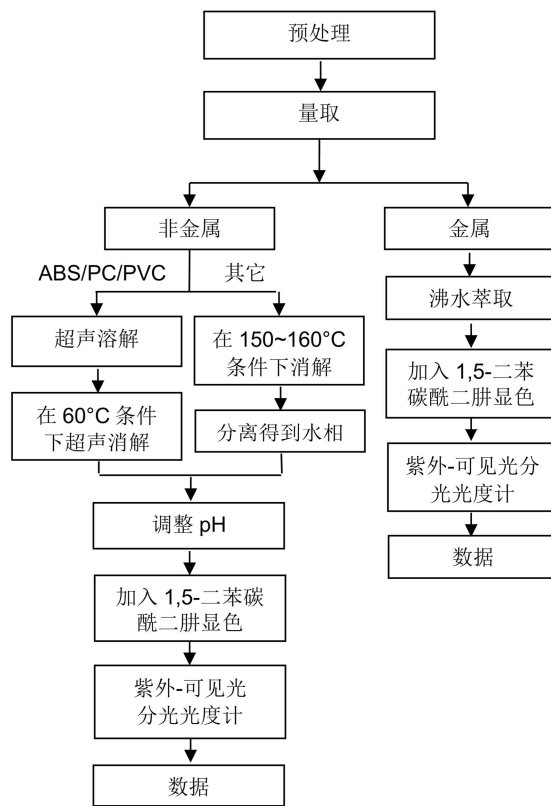

Unless otherwise agreed in writing, this document is issued by the Company subject to its General Conditions of Service printed overleaf, available on request or accessible at <http://www.sgs.com/en/Terms-and-Conditions.aspx> and, for electronic format documents, subject to Terms and Conditions for Electronic Documents at <http://www.sgs.com/en/Terms-and-Conditions/Terms-e-Documents.aspx>. Attention is drawn to the limitation of liability, indemnification and jurisdiction issues defined therein. Any holder of this document is advised that information contained hereon reflects the Company's findings at the time of its intervention only and within the limits of Client's instructions, if any. The Company's sole responsibility is to its Client and this document does not exonerate parties to a transaction from exercising all their rights and obligations under the transaction documents. This document cannot be reproduced except in full, without prior written approval of the Company. Any unauthorized alteration, forgery or falsification of the content or appearance of this document is unlawful and offenders may be prosecuted to the fullest extent of the law. Unless otherwise stated the results shown in this test report refer only to the sample(s) tested.

Attention: To check the authenticity of testing/inspection report & certificate, please contact us at telephone: (86-755) 8307 1443, or email: CN.Doccheck@sgs.com

SGS-CSTC (Shanghai) Technical Services Co., Ltd. 3rd Building, No.889 Yishan Road Xuhui District, Shanghai China 200233 t E&E (86-21) 61402553 f E&E (86-21) 64953679 www.sgs.com.cn
 Testing Center - China Technical Services 中国·上海·徐汇区宜山路889号3号楼 邮编: 200233 t HL (86-21) 61402594 f HL (86-21) 61156899 e sgs.china@sgs.com

Member of the SGS Group (SGS SA)



检测报告

编号: SHAEC23005417604

日期: 2023年05月09日

第5页, 共7页

附件:

1.0, SH, SHD, 1.25, 51021, DF14, DF13, GH, ZH, PH, PHB, PA, PHSD, DF11, C1251, 51047, 51146, FI-S, PHD, YHD200, PA, SMP, SMW, SMH, SMH200-H, YH200, 20039WR, 杜邦 2.0, XH/TJC3, XA, HA, XHB, XHD, XHE, EH, EI, 小四 P, 5263, 5264, 5267, 5268, SZN, SAN, SCN, SCND, JC15, JC20, JC25, 5102, 5240, SMH250, SMP250, SMW250, 25048HS, 25045HP, SM, TJC8, 杜邦 2.54, TJC8A, 杜邦带锁, TJC8B, TJC8H, 5051, 2510, 美尚美, 43640, 43645, 43020, 43025, 5500, 5600, VH, VHRR, YH396, VHR, 35156, 2139, 3.96, 90331, 5195, 5196, 39612, FL, 5557, 5559, 5566, 5569, SL, RV42, EL, YL, 小 EL, 8981, 大四 P, 5058, 5.08, L6.2, VL, VLP/VLR, TJC2, TJC2A, TJC2B, TJC4, TJC1, 1806, MX3.0, 1.58, 51005, 51006, BH3.5, BH4.0, 63080, 51004, TJC15, A4203, CL014, OTP, MKH, SMF, Cy-X201, 35108, 35150, 35151, 35152, 35180, 35965, 42021, 42022, 42002, 35955, SA, SCS, 35189, 35196, CH10, CH2.5, 543, SLP, SLR, YHL500, YWL500, FFC, FPC, 20030, 250, LGC, S11, YH025, 35155, 25415, 5197, 5198, 110, 2.8, 6.3, SCS

NH, XHQ, 42474, 42475, QH, NV, 50300, 50301, 5025, 3191, 5199, STV5, YHL500, YWL500, F001, F002, D440, D600, D620, D700, D220, D230, D250, D480, D520, D280, D630, D430, D400, D450, U-T, F1001-T, SIN-T, 774, 773, 778, 294, TU-JTK(SV), TU(SNB), TO-JTK(RV), MDD, FDD, TG-JT, IDC, AUTO, CONNECTOR, DJ70, DT04, DT06, UY/K1, UY2/K2, UR/K3, UR2, UB/K4, UB2A, UG/K5, U1R/K8, U1B/K9, HJKT10, UDW2, 314, A5001, A5002, MC100, FPC2.54, SGN, PHR, ZHR, 205, 5.2, C1801, C1802, 2060, A5003, ME020, ME010, FPC/FFC, B2541, 1971845, 1971846, 2232043, 2232044, 2232511, 1971895, 1971896, JWPF, SY, Molex1.5, ME0100, RAST, A5004, DV, SJN, SDN, 35182, 35524, RCY, LC, VR, SHJ, SHL, DF19, ACH, IL-Z, SATA, XSR, SUR, SUH, ZE, ZND, ZPD, SFH, PUD, AMP2.0, 35507, DF3, PND, RE, RA, RF, SYP/SYR, HIF3, MC100/ME020/ME010, F2541, VHB, VHC, VHD

1969738, 1969740, 1971845, 1971846, 1971895, 1971896, 1971946 thru 1971949, 1971954 thru 1971957, 2232008 thru 2232011, 2232000 thru 2232003, 2232016 thru 2232019, 1971962 thru 1971965, 2232024 thru 2232027, 2232289 thru 2232292, 2232043 thru 2232074, 2232298 thru 2232301, 2232511, 2232532, 2232557, 2232559, 2232560, 2232562, 2232563, 2232565, 2232566, 2232568, 2232569, 2232571, 2232572, 2232574, 2232575, 2232577, 2232578, 2232580, 2232581, 2232583, 2232584, 2232586, 2232587, 2232589, 2232590, 2232592, 2232593, 2232595, 2232596, 2232598, 2232599, 2232601, 2232602, 2232604, 2232605, 2232607, 2232608, 2232611 thru 2232682, 2292457, 2292458, 1064,2064,3064,1080,2080,3080,1100,2100,3100,1120, 2120,3120,1150,2150,3150, 1180,2180,3180,1230,2230, 3230,1250,2250,3250,1280,2280,3280,1300,2300,3300, 1480,2480,3480, 1630,2630,3630,1780,2780,3780,1950, 2950,3950,1010,2010,3010,1013,2013,3013,1015,2015, 3015, 1016,2016,3016,1025,2025,3025,1035,2035,3035, 1045,2045,3045,1058,2058,3058,1999,2999,3999, 401,402,403,503,TPA,BX

A1001 A1002 A1003 A1004 A1005 A1006 A1007 A1008 A1009
A1251 A1252 A1253 A1254 A1255 A1256 A1257 A1258 A1259
A1501 A1502 A1503 A1504 A1505 A1506 A1507 A1508 A1509
A2001 A2002 A2003 A2004 A2005 A2006 A2007 A2008 A2009
A2010 A2011 A2012 A2013 A2014 A2015 A2016 A2017 A2018
A2501 A2502 A2503 A2504 A2505 A2506 A2507 A2508 A2509
A25010 A25011 A25012 A25013 A25014 A25015 A25016 A25017 A25018
A2541 A2542 A2543 A2544 A2545 A2546 A2547 A2548 A2549
A3001 A3002 A3003 A3004 A3005 A3006 A3007 A3008 A3009
A3301 A3302 A3303 A3304 A3305 A3306 A3307 A3308 A3309



Unless otherwise agreed in writing, this document is issued by the Company subject to its General Conditions of Service printed overleaf, available on request or accessible at <http://www.sgs.com/en/terms-and-conditions.aspx> and, for electronic format documents, subject to Terms and Conditions for Electronic Documents at <http://www.sgs.com/en/terms-and-conditions/terms-e-document.aspx>. Attention is drawn to the limitation of liability, indemnification and jurisdiction issues defined therein. Any holder of this document is advised that information contained hereon reflects the Company's findings at the time of its intervention only and within the limits of Client's instructions, if any. The Company's sole responsibility is to its Client and this document does not exonerate parties to a transaction from exercising all their rights and obligations under the transaction documents. This document cannot be reproduced except in full, without prior written approval of the Company. Any unauthorized alteration, forgery or falsification of the content or appearance of this document is unlawful and offenders may be prosecuted to the fullest extent of the law. Unless otherwise stated the results shown in this test report refer only to the sample(s) tested.
Attention: To check the authenticity of testing/inspection report & certificate, please contact us at telephone: (86-755) 8307 1443, or email: CN.Doccheck@sgs.com
3rd Building No.889 Yeshan Road Xuhui District, Shanghai China 200233 t E8E (86-21) 61402553 f E8E (86-21) 64053679 www.sgs.com.cn
中国·上海·徐汇区宜山路889号3号楼 邮编: 200233 t HL (86-21) 61402594 f HL (86-21) 61156899 e sgs.china@sgs.com

Member of the SGS Group (SGS SA)



检测报告

编号: SHAEC23005417604

日期: 2023年05月09日

第6页, 共7页

A3961 A3962 A3963 A3964 A3965 A3966 A3967 A3968 A3969
A4201 A4202 A4203 A4204 A4205 A4206 A4207 A4208 A4209
A5001 A5002 A5003 A5004 A5005 A5006 A5007 A5008 A5009
A5081 A5082 A5083 A5084 A5085 A5086 A5087 A5088 A5089
A6501 A6502 A6503 A6504 A6505 A6506 A6507 A6508 A6509
B1251 B1252 B1253 B1254 B1255 B1256 B1257 B1258 B1259
B1501 B1502 B1503 B1504 B1505 B1506 B1507 B1508 B1509
B2001 B2002 B2003 B2004 B2005 B2006 B2007 B2008 B2009
B2501 B2502 B2503 B2504 B2505 B2506 B2507 B2508 B2509
B2541 B2542 B2543 B2544 B2545 B2546 B2547 B2548 B2549
B76201 B76202 B76203 B76204 B76205 B76206 B76207 B76208 B76209
B13001 B13002 B13003 B13004 B13005 B13006 B13007 B13008 B13009
C01581 C01582 C01583 C01584 C01585 C01586 C01587 C01588 C01589
C1251 C1252 C1253 C1254 C1255 C1256 C1257 C1258 C1259
C1501 C1502 C1503 C1504 C1505 C1506 C1507 C1508 C1509
C2001 C2002 C2003 C2004 C2005 C2006 C2007 C2008 C2009
C2501 C2502 C2503 C2504 C2505 C2506 C2507 C2508 C2509
C25010 C25011 C25012 C25013 C25014 C25015 C25016 C25017 C25018
C2541 C2542 C2543 C2544 C2545 C2546 C2547 C2548 C2549
C3001 C3002 C3003 C3004 C3005 C3006 C3007 C3008 C3009
C3501 C3502 C3503 C3504 C3505 C3506 C3507 C3508 C3509
C3681 C3682 C3683 C3684 C3685 C3686 C3687 C3688 C3689
C3961 C3962 C3963 C3964 C3965 C3966 C3967 C3968 C3969
C4001 C4002 C4003 C4004 C4005 C4006 C4007 C4008 C4009
C4141 C4142 C4143 C4144 C4145 C4146 C4147 C4148 C4149
C4201 C4202 C4203 C4204 C4205 C4206 C4207 C4208 C4209
C4501 C4502 C4503 C4504 C4505 C4506 C4507 C4508 C4509
C5001 C5002 C5003 C5004 C5005 C5006 C5007 C5008 C5009
C6201 C6202 C6203 C6204 C6205 C6206 C6207 C6208 C6209
C6351 C6352 C6353 C6354 C6355 C6356 C6357 C6358 C6359
D2801 D2802 D2803 D2804 D2805 D2806 D2807 D2808 D2809
D4801 D4802 D4803 D4804 D4805 D4806 D4807 D4808 D4809
D5201 D5202 D5203 D5204 D5205 D5206 D5207 D5208 D5209
D6301 D6302 D6303 D6304 D6305 D6306 D6307 D6308 D6309
D6201 D6202 D6203 D6204 D6205 D6206 D6207 D6208 D6209
D7001 D7002 D7003 D7004 D7005 D7006 D7007 D7008 D7009
F0501 F0502 F0503 F0504 F0505 F0506 F0507 F0508 F0509
F05010 F05011 F05012 F05013 F05014 F05015 F05016 F05017 F05018
F1001 F1002 F1003 F1004 F1005 F1006 F1007 F1008 F1009
F10010 F10011 F10012 F10013 F10014 F10015 F10016 F10017 F10018
F2541 F2542 F2543 F2544 F2545 F2546 F2547 F2548 F2549
P0001 P0002 P0003 P0004 P0005 P0006 P0007 P0008 P0009
P0010 P0011 P0012 P0013 P0014 P0015 P0016 P0017 P0018
P0019 P0020 P0021 P0022 P0023 P0024 P0025 P0026 P0027
D2301 D2302 D2303 D2304 D2305 D2306 D2307 D2308 D2309
D6001 D6002 D6003 D6004 D6005 D6006 D6007 D6008 D6009
D2201 D2202 D2203 D2204 D2205 D2206 D2207 D2208 D2209



Unless otherwise agreed in writing, this document is issued by the Company subject to its General Conditions of Service printed overleaf, available on request or accessible at <http://www.sgs.com/en/Terms-and-Conditions.aspx> and, for electronic format documents, subject to Terms and Conditions for Electronic Documents at <http://www.sgs.com/en/Terms-and-Conditions/Terms-e-Documents.aspx>. Attention is drawn to the limitation of liability, indemnification and jurisdiction issues defined therein. Any holder of this document is advised that information contained hereon reflects the Company's findings at the time of its intervention only and within the limits of Client's instructions, if any. The Company's sole responsibility is to its Client and this document does not exonerate parties to a transaction from exercising all their rights and obligations under the transaction documents. This document cannot be reproduced except in full, without prior written approval of the Company. Any unauthorized alteration, forgery or falsification of the content or appearance of this document is unlawful and offenders may be prosecuted to the fullest extent of the law. Unless otherwise stated the results shown in this test report refer only to the sample(s) tested.

Attention: To check the authenticity of testing / inspection report & certificate, please contact us at telephone: (86-755) 8307 1443, or email: CN.Doccheck@sgs.com

SGS SCS (Shanghai) Technical Services Co., Ltd. 3rd Building, No. 889 Yishan Road Xuhui District, Shanghai China 200233 | E&E (86-21) 61402553 | E&E (86-21) 64953679 | www.sgs.com.cn
中国·上海·徐汇区宜山路889号3号楼 邮编: 200233 | T HL (86-21) 61402594 | F HL (86-21) 61156899 | e.sgs.china@sgs.com

Member of the SGS Group (SGS SA)



检测报告

编号: SHAEC23005417604

日期: 2023年05月09日

第7页, 共7页

样品照片:



此照片仅限于随 SGS 正本报告使用
报告结束



Unless otherwise agreed in writing, this document is issued by the Company subject to its General Conditions of Service printed overleaf, available on request or accessible at <http://www.sgs.com/en/Terms-and-Conditions.aspx> and, for electronic format documents, subject to Terms and Conditions for Electronic Documents at <http://www.sgs.com/en/Terms-and-Conditions/Terms-e-Documents.aspx>. Attention is drawn to the limitation of liability, indemnification and jurisdiction issues defined therein. Any holder of this document is advised that information contained hereon reflects the Company's findings at the time of its intervention only and within the limits of Client's instructions, if any. The Company's sole responsibility is to its Client and this document does not exonerate parties to a transaction from exercising all their rights and obligations under the transaction documents. This document cannot be reproduced except in full, without prior written approval of the Company. Any unauthorized alteration, forgery or falsification of the content or appearance of this document is unlawful and offenders may be prosecuted to the fullest extent of the law. Unless otherwise stated the results shown in this test report refer only to the sample(s) tested.

Attention: To check the authenticity of testing / inspection report & certificate, please contact us at telephone: (86-755) 8307 1443, or email: CN.Doccheck@sgs.com

3rd Building, No.889 Yishan Road Xuhui District, Shanghai China 200233 tE&E (86-21) 61402553 fE&E (86-21) 64953679 www.sgs.com.cn
中国·上海·徐汇区宜山路889号3号楼 邮编: 200233 tHL (86-21) 61402594 fHL (86-21) 61156899 e sgs.china@sgs.com

Member of the SGS Group (SGS SA)

编号: LHES006		
MSDS		
1. 物品成分与厂商资料		
厂商名称: 浙江联和电子有限公司	物品编号: QSN6.5-0.1	
	物品名称: 磷铜端子	
	纯物质:	
	危害物质成分 (%) 无	
2. 成份辨识资料		
成份名称	化学文摘社登记号码(CAS No.)	浓度范围 (成分百分比 Percentage (%))
铜(Cu)	7440-50-8	余量
磷(P)	7723-14-0	0.0026-0.005%
锌(Zn)	7440-66-6	0.03-0.04%
镍(Ni)	7440-02-0	0.054-0.063%
锑(Sb)	7440-36-0	0.00015%
铅(Pb)	7439-92-1	<0.005%
铁(Fe)	7439-89-6	0.005-0.0059%
纯镍(Ni)	7440-02-0	0.054-0.063%
纯锡(Sn)	7440-31-5	6.2 %
2. 危害辨认资料		
严重危害效应	健康危害效应: 本产品 在固体时不具健康危害及危害	
	环境影响: 本产品 在固体时对环境不具影响	
	物理性及化学性危害: 固体/无味/多色	
	特殊危害: 固体时 (防火或高温) 无特殊危害	
主要症状: 无		
3. 急救措施		
急救方法	吸入: 无吸入	
	皮肤接触: 接触无危害	
	食入: 无食入	
主要症状及危害效应: 无		
4. 灭火措施		
通用灭火器: 二氧化碳, 泡沫, 干粉化学灭火器, 水雾等		
灭火时可能遭遇之特殊危害: 会引起火灾		
消防人员之特殊防护装备: 使用从氧式吸防护具		
5. 泄漏处理方法		
个人应注意事项: 注意工作台面清洁, 作业时及时清洗手		
环境注意事项: 将泄漏之物料以容器盛装以便回收或废弃		
清理方式: 工作台面每天作业前/后须擦拭干净, 建议可以戴手套或手指套作业		
6. 安全处置与储存方法		
处置: 废弃物可送到政府许可的废弃物处理中心进行处理		

储存: 空调仓, 23±5℃, 湿度 65%以下, 仓库里面安装灭火器	
7. 暴露预防措施	
个人防护设备	呼吸防护: 口罩, 一般无此要求, 可以建议采用
	手部防护设备: 手套火手指套, 一般无此要求, 可以建议采用
	眼睛防护: 安全目镜或眼镜
	皮肤及身体防护: 穿工作服, 经常勤洗
卫生措施: 建议使用安全目镜, 进食前应洗手及脸部, 平时多运动, 保持健康体力	
8. 材料及化学性质	
物质状态: 固体	形状: 连接器
颜色: 多色	气味: 无味
PH 值: 未测定	沸点: 未测定
分解温度: 未测定	爆炸介限: 无
自然温度: 固体无	溶解度: 固体无
9. 安全性及反应性	
安全性: 正常状态下安全	
特殊状况下可能之危害反应: 无	
应避免之状况: 避免接触火源和太阳光直照射	
应避免之物质: 火和酸碱性物质	
危害分解物: 无	
10. 毒性资料	
急毒性	吸入: 无
	皮肤接触: 无
	眼睛: 无
局部效应: 无	特殊效应: 无
11. 废弃物处理方法: 废弃物可送到政府许可的废弃物处理中心进行处理	
12. 运送资料	
联合国编号: 无	运输规定: 并无危险分类
运送方法及注意事项: 勿重压, 轻拿轻放	
13. 适用法规: 1.劳工安全卫生设施规划; 2.危害物及有害物通讯规划; 3.索尼环境通用规定; 4 劳工用业环境空气中有害物容许溶度标准; 5 道路交通安全规划	
14. 其他资料:	
15.法规资料	
适用法规	1.劳工安全卫生设施规则 2.RoHS 法规及有害物通识规则
16.其它资料	
参考文献	有害化学物质中文资料库, 环保局
制表单位	浙江联和电子有限公司
制造商及供应商地址	浙江省温州市乐清市乐清湾港区创新路8号
电话	0577-62383699
制表者	季育文
制表日期	2022-3-23

927833型端子承认书



A series of 22 horizontal lines spanning the width of the page, providing a structured area for writing or drawing. The lines are evenly spaced and extend from the left margin to the right margin.