

**Features**

- Supports NFC function
- DALI or PUSH dimmable
- Dim to off without afterglow
- Supports 2 sets of light fixtures connected in series
- Output current set via external resistor
- Output current and output lumen compensation set via programmer
- Supports logarithmic dimming (default setting) and linear dimming
- Supports corridor lighting and emergency lighting
- Suitable for Class I light fixtures



**Applications**

· Indoor office lighting · decorative lighting · commercial lighting · residential lighting

**Descriptions**

LF-FSD150YA is a 150W (max.) non-isolated DALI NFC dimmable constant current LED driver featuring 150W constant power output. Its rated input voltage ranges from 220 to 240Vac; output voltage from 64 to 300Vdc and output current from 250 to 1000mA. It supports DALI or PUSH dimming, corridor lighting, emergency lighting and NFC programmer. It is suitable for Class I light fixtures, including linear light, tri-proof light, etc.

**Product Model**

LF - FSD 150 YA

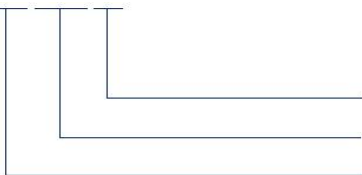

- Y: complies with certifications; A: serial number
- 150: output power: 150W
- F: non-isolated design; SD: indoor dimmable LED driver

### ■ Electrical Characteristics

Model		LF-FSD150YA				
<b>Output</b>	Output Voltage	64-300V				
	Output Current	250-1000mA <sup>①</sup> (default current: 350mA <sup>②</sup> )				
	Flicker Index	IEC-Pst ≤1, CIE SVM ≤0.4 Complies with IEEE Std 1789-2015				
	Current Tolerance	±5%				
	Temperature Drift	±10%				
<b>Input</b>	Input Voltage	220-240Vac (voltage limit: 198-264Vac)				
	DC Input Voltage	180-264Vdc				
	Input Frequency	0/50/60Hz				
	Input Current	0.85A max.				
	PF	≥0.98				
	THD	<10%				
	Efficiency	≥95%				
	Inrush Current	60A&280uS				
	Loading Quantities of Circuit Breaker	Model	B10	C10	B16	C16
		Quantity (pcs)	5	7	8	12
	Leakage Current	<0.7mA				
Standby Power Consumption	≤0.35W (DALI OFF)					
<b>Protections</b>	Open Circuit	<310V				
	Short Circuit	Hiccup mode (auto-recovery)				
<b>Environment Descriptions</b>	Operating Temperature	-40°C~+65°C				
	Operating Humidity	00-90%RH (no condensation)				
	Storage Temperature/ Humidity	-40°C~+85°C (6 months in Class I environment); 10-90%RH (no condensation)				
	Atmospheric Pressure	86-106kPa				

### ■ Electrical Characteristics

<b>Safety and EMC</b>	Certifications	ENEC, CE, CB, UKCA, RCM, EL, CCC
	Withstanding Voltage	I/P-PG: 1.5kV 5mA 60S I/P-DA1/DA2: 1.5kV 5mA 60S DA1/DA2-PG 1.5kV 5mA 60S
	Insulation Resistance	I/P-PG: >100MΩ@500VDC I/P-DA1/DA2: >100MΩ@500VDC DA1/DA2-FG:500VDC,>100MΩ
	Safety Standards	ENEC: EN61347-1:2015, EN 61347-2-13:2014/A1:2017, EN 62384: 2016/A1:2009 CE-LVD: EN 61347-2-13:2014/A1:2017, EN 61347-1:2015, EN 62493:2015 CB:IEC 61347-1:2015, IEC61347-2-3:2014, IEC 61347-2-13:2014/AMD1:2016 RCM:AS 61347.2-13:2018 EL:IEC 61347-2-13:2014 Annex J UKCA: BS EN IEC 55015: 2019+A11: 2020, BS EN 61547: 2009, BS EN IEC 61000-3-2: 2019, BS EN 61000-3-3: 2013/A2: 2021 CCC:GB19510.1-2009, GB19510.14-2009
	EMI	CE-EMC:EN55015, EN61000-3-2, EN61000-3-3 CCC:GB/T17743, GB17625.1, GB17625.2
	EMS	CE-EMC: EN61000-4-2,3,4,5 (Lightning Strike L-N:4kV,LN-PG:6kV),6,11 CCC:GB/T17626.2,3,4,5 (Lightning Strike L-N:4kV,LN-PG:6kV),6,11
	DALI Inrush	DA1-DA2:0.5kV
<b>Other Parameters</b>	IP Rating	IP20
	RoHS	RoHS 2.0 (EU) 2015/863
	Warranty Condition	5 years (Tc≤82°C)
	Lifetime	100,000 hours (subject to the requirements specified in this data sheet)
	Compatibility of DALI Dimming <sup>®</sup>	Yuanhao Master, Philips Master DDBC120-DALI, OSRAM Master, Helvar Master 905 Router, Tridonic Master-24138923 and HDL MC64-DALI431 Master
	DALI Standard	IEC 62386-101 102 207: DALI 2.0
<b>Testing Equipment</b>	AC power source: CHROMA6530, digital power meter: CHROMA66202, oscilloscope: Tektronix DPO3014, DC electronic load: M9712B, LED board, constant temperature and humidity chamber; Everfine EMS61000-5B, fast transient generator: Everfine EMS61000-4A, spectroanalyzer: KH3935, hi-pot tester: EEC SE7440, flicker tester (flicker-free coefficient test): Everfine LFA-3000, etc.	
<b>Testing Remark</b>	If there are no special remarks, the above parameters are tested at the ambient temperature of 25°C, humidity of 50%, full load and input voltage of 230Vac/50Hz.	

■ **Electrical Characteristics**

<p><b>Additional Remarks</b></p>	<ol style="list-style-type: none"> <li>1. It is recommended that user install the over voltage protection, under voltage protection and surge protection devices in the power supply circuits of light fixtures to ensure electricity safety.</li> <li>2. The LED driver used in combination with the end device is one of the accessories of the whole light fixture, and the EMC of the whole light fixture is not only susceptible to the driver itself, but to the LED light fixture and the whole light fixture's wiring. Thus, the manufacturer of LED light fixture should re-confirm the EMC of the whole light fixture before the whole light fixture is finished.</li> <li>3. The test conditions of the circuit breaker configuration quantity are the same as those of the inrush current.</li> <li>4. The PC cover, casing and end cap for assembling the LED driver in the light fixture must meet the fire rating of UL94-V0 or above.</li> <li>5. In no-load condition, it is recommended that user not directly connect the LED driver to the light fixture in case that the light fixture is damaged.</li> <li>6. It is well-advised that the withstanding voltage of LEDs and aluminum substrates &gt;3kVac.</li> <li>7. If the parasitic capacitance between LEDs and the PCBA is too large, and the light fixture is grounding, there will be a slight flicker at the moment of power on.</li> </ol> <p>Note: ① When the load voltage of LED driver ranges from 64 to 150Vdc, the LED driver outputs with the maximum constant current of 1000mA; when the load voltage &gt;150Vdc, the LED driver outputs with the constant power of 150W(±3W).</p> <p>② The default current of LED driver is 350mA and its output current has two settings:</p> <ol style="list-style-type: none"> <li>1) Set by Lifud programmer and DALI programming software(or FEIG NFC reader)</li> <li>2) Set by the external resistor at LEDset terminal</li> </ol> <p>③ When using other DALI masters, please test their compatibilities with Lifud LED driver in advance.</p>
----------------------------------	---

■ **Product Characteristic Curves**

PF Curve

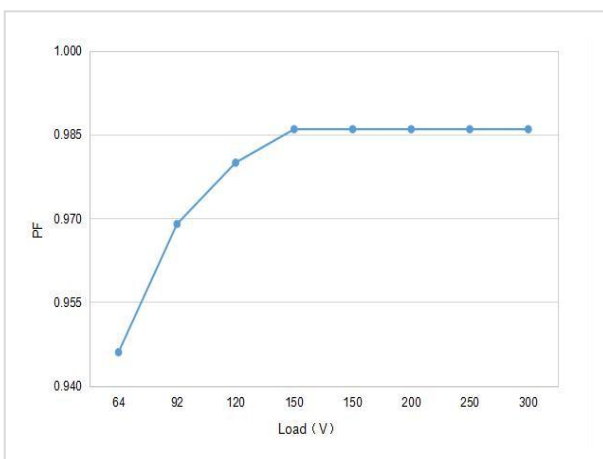

Efficiency Curve

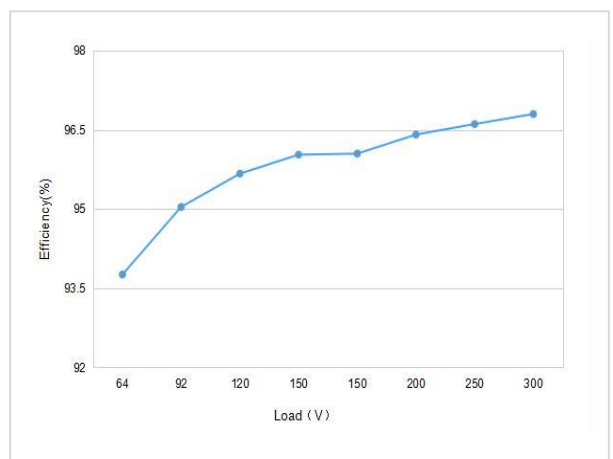

■ Product Characteristic Curves

Working Curve

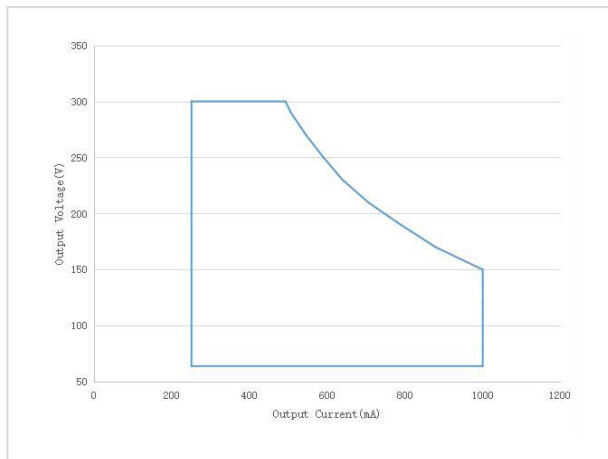

Output Current & Rset Curve

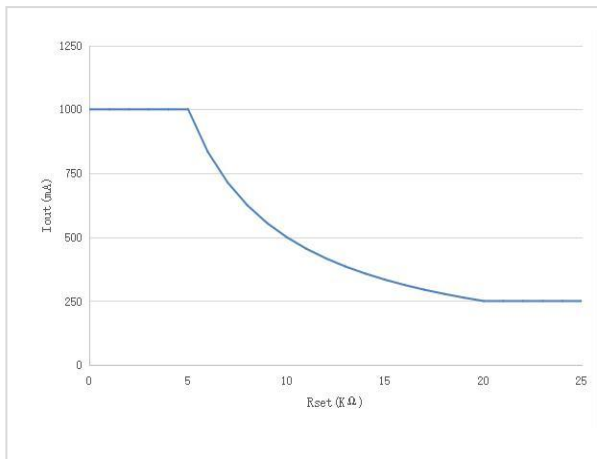

Lifetime Curve

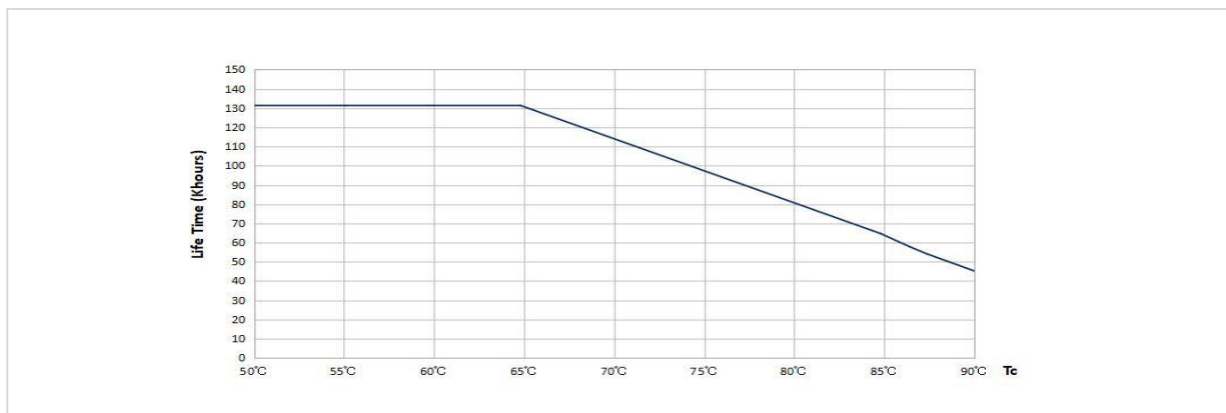

Tc Point (unit: mm)

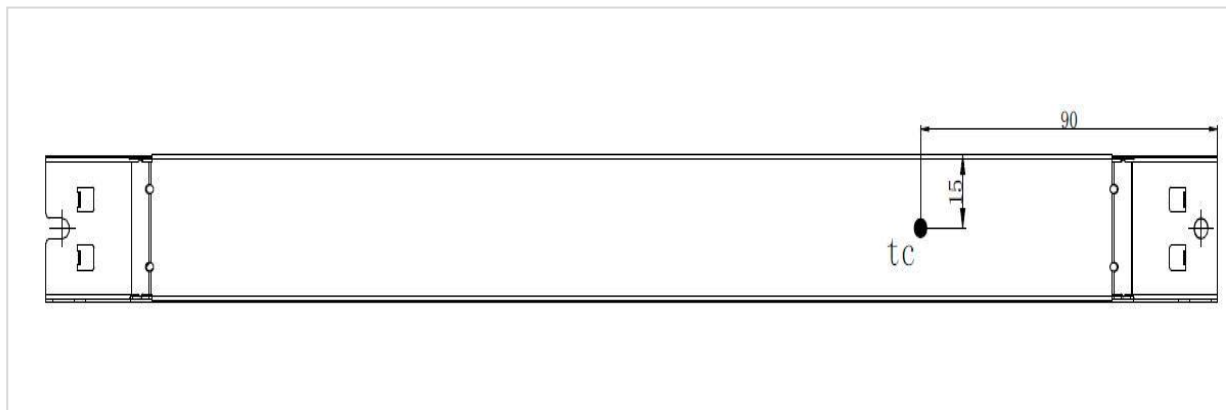

■ **Product Terminal Definition**

Product Terminals

INPUT		OUTPUT	
AC-L (grey terminal)	AC live wire input	LED+ (red terminal)	Positive electrode output of LED driver
AC-N (grey terminal)	AC neutral wire input	- (black terminal)	Negative electrode of LED board in series
/	/	+ (red terminal)	Positive electrode of LED board in series
 (grey terminal)	Earth wire input	LED- (black terminal)	Negative electrode output of LED driver
DA1 PUSH (green terminal)	DALI 1/PUSH dimming input	LEDset+ (orange terminal)	Rset resistor input 1
DA2 PUSH (green terminal)	DALI 2/PUSH dimming input	LEDset- (orange terminal)	Rset resistor input 2

Wiring Diagram of Product Output Terminal

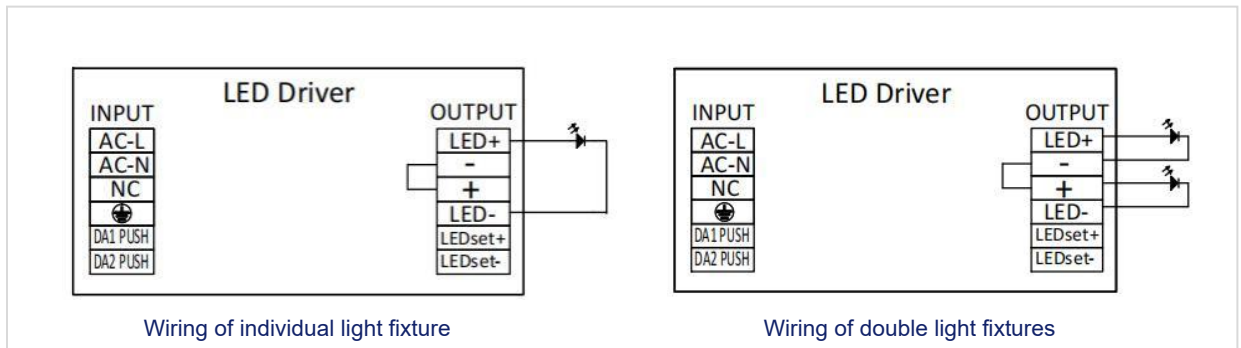



 Do not connect LED set+ to LED- in case that the LED driver is damaged.

■ **Dimming Operation Instructions**

Wiring Diagram of PUSH Dimming

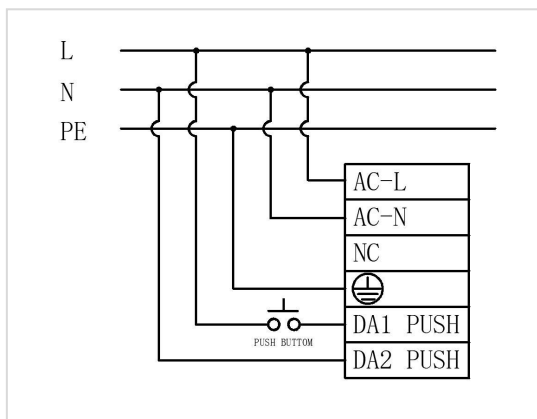
Remarks



- Connect PUSH switch between AC-L and DA1 PUSH in series and connect DA2 PUSH to AC-N.
- Make sure that AC-L and AC-N are not directly connected to DA1 PUSH and DA2 PUSH terminals.
- Make sure that PUSH switch is off before the AC is powered on; operate PUSH after the AC is powered on.
- Make sure the PUSH switch is off before disconnecting the AC.
- If you have any questions about the wiring and operation, please confirm with Lifud FAE.
-  Wrong wiring or operation may cause damage to the driver.

**■ Dimming Operation Instructions**

Operations of PUSH Dimming

Operation	Duration	Function
Instant Push	0.1-0.5 sec	LED light on/off
Long Push	0.6-9 sec	LED light dim up/down
Reset Push	>15 sec	Reset the brightness of all luminaires to 50%

- The PUSH operation won't cause any variations on LED driver if it's less than 0.1S.
- Dimming depth of PUSH dimming: 1%
- The PUSH dimming mode has the memory function in case of any power failure. When the LED driver is powered on again, the light will return to the previous state before power failure.
- The present dimming direction of PUSH dimming is opposite to the former one.
- In AUTO mode, press for 3+ mins to switch to corridor lighting.

Operations of DALI Dimming

Wiring Diagram of DALI Dimming

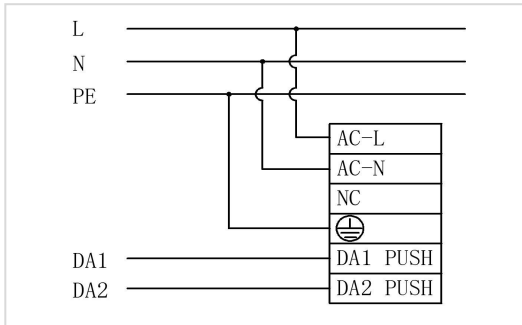

Operations of DALI Dimming

- Default setting brightness is 100%.
- Connect DALI signal to DA1 PUSH and DA2 PUSH.
- DALI protocol includes Max.16 scene groups.
- Maximum number of LED drivers connected in parallel in DALI dimming mode: 64 pcs.
- Dimming depth of DALI dimming: 1%.
- ⚠ Choose only ONE as opposed to use DALI or PUSH at the same time in case of the damage of DALI master.

DALI Dimming Curve

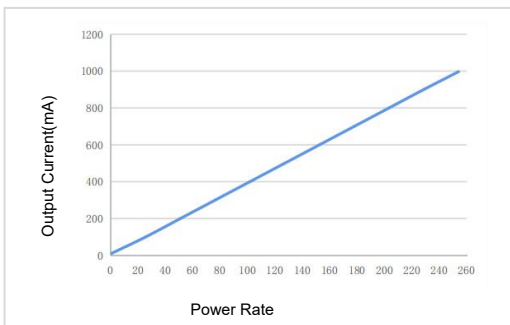

logarithmic dimming

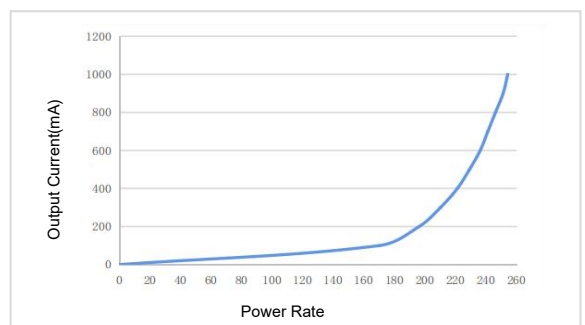

linear dimming

**LEDset Current Setting Instructions**

Wiring Diagram of LEDset

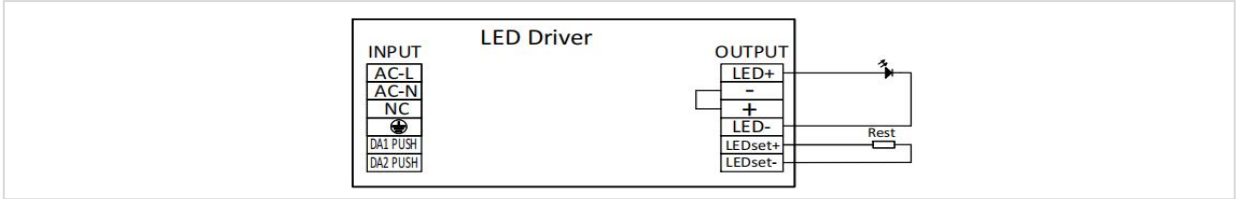

- Default current: 350mA
- The LED driver outputs with the current of 1000mA when the resistance value of LEDset ranges from 0 to 5KΩ
- The LED driver outputs with the current that ranges from 250 to 1000mA when the resistance value of LEDset ranges from 5 to 20KΩ [reference formula:  $I_{out} = (5/R_{set}) * 1000mA$ ; unit of  $R_{set}$ : KΩ]
- The LED driver outputs with the current of 250mA when the resistance value of LEDset ranges from 20-100KΩ
- The LED driver outputs with the default current of 350mA when the resistance value of LEDset >120KΩ or Not connected.

Reference Table for Output Current of Resistor Connected at LEDset

R (KΩ)	0-5	5. 05	5. 10	5. 15	5. 21	5. 26	5. 32	5. 38	5. 43	5. 49
I <sub>out</sub> (mA)	1000	990	980	970	960	950	940	930	920	910
5. 56	5. 62	5. 68	5. 75	5. 81	5. 88	5. 95	6. 02	6. 10	6. 17	6. 25
900	890	880	870	860	850	840	830	820	810	800
6. 33	6. 41	6. 49	6. 58	6. 67	6. 76	6. 85	6. 94	7. 04	7. 14	7. 25
790	780	770	760	750	740	730	720	710	700	690
7. 35	7. 46	7. 58	7. 69	7. 81	7. 94	8. 06	8. 20	8. 33	8. 47	8. 62
680	670	660	650	640	630	620	610	600	590	580
8. 77	8. 93	9. 09	9. 26	9. 43	9. 62	9. 80	10. 00	10. 20	10. 42	10. 64
570	560	550	540	530	520	510	500	490	480	470
10. 87	11. 11	11. 36	11. 63	11. 90	12. 20	12. 50	12. 82	13. 16	13. 51	13. 89
460	450	440	430	420	410	400	390	380	370	360
14. 29	14. 71	15. 15	15. 63	16. 13	16. 67	17. 24	17. 86	18. 52	19. 23	20-100
350	340	330	320	310	300	290	280	270	260	250

**Corridor Dimming Mode Instructions**

Wiring Diagram of Corridor Dimming Operation

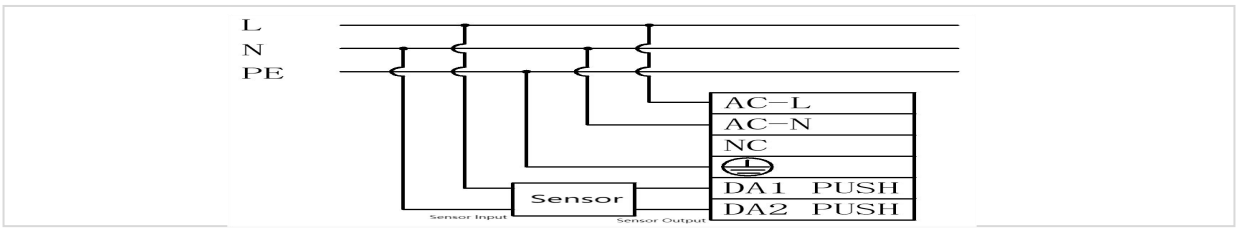



■ **Corridor Lighting Mode Instructions**

Operations for Entering Corridor Lighting Mode

- **Approach 1:** use Lifud programmer to enable the driver’s corridor lighting mode and set parameters.
- **Approach 2:** keep pressing PUSH for 3+ mins so as to switch to the corridor lighting mode.
- **Approach 3:** keep moving in the effective sensing area for 3+ mins (set the sensor’s hold time for 3+ mins to enable the corridor lighting mode).
- Remarks:
  1. In the automatic detection mode, the driver can be switched from PUSH mode to corridor lighting mode by approach 2 and 3, its brightness will dim up to 50%; long press for 3 mins and then it dims down and then dims up, which means the driver has entered the corridor lighting mode.
  2. After activating the corridor dimming mode, PUSH DIM is turned off.
- 3. In the case of AC input and any level of brightness in the corridor lighting mode, switching DC and then return AC will restart the corridor lighting mode.

Operations for Exiting Corridor Lighting Mode

- **Approach 1:** use Lifud programmer to choose other modes and exit corridor lighting mode.
- **Approach 2:** connect to DALI master and send DALI command, the driver will return to the DALI dimming mode.
- **Approach 3:** connect to the PUSH switch and continuously press it 10 times within 10 secs, the driver will return to the PUSH dimming mode.
- Remark:
  1. The 3-sec or above single press or release will cause the press number (10 times) to be counted as 0.
  2. The approach 2 and 3 **CANNOT** be used if the corridor lighting mode of driver is set via Lifud programmer.

Working Process of Corridor Dimming Mode

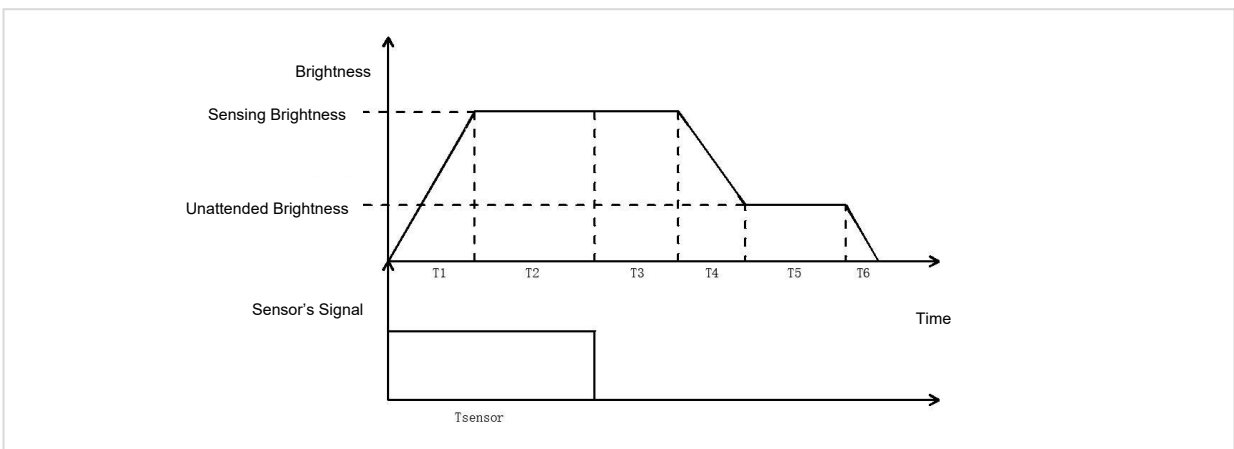

Symbol	Name	Default Value	Available Scope Setting
T1	Fade-in time of sensing	1 sec	0-100 sec
T2	Holding time of sensing	Depends on sensor	Depends on sensor
T3	Waiting time of sensing	180 sec	0-59999 sec, 60000 sec (infinite)
T4	Fade-out time of sensing	5 sec	0-100 sec
T5	Unattended time	60000 sec (infinite)	0-59999 sec, 60000 sec (infinite)
T6	Fade-out off time	0 sec	0-100 sec
L1	Sensing brightness	100%	0-100%
L2	Unattended brightness	10%	0-100%

### ■ Emergency Function Instructions

The default output current is 15% I<sub>o max</sub> in the case of DC emergency input.

Emergency input voltage: 180-264Vdc

Note:

- Emergency function can be set by Lifud programmer and programming software(or FEIG NFC reader)
- If the emergency mode is on,input current is DC and output current is preset current; if the mode is off, input current is DC and the working mode is the same as the AC input.
- In the case of mains input, the brightness is random when using PUSH dimming, disconnect AC (mains) and connect DC, the driver will enter the emergency escape lighting system; disconnect DC and connect AC (mains), the light brightness will remain the one set via PUSH switch when mains is connected.
- In the case of mains input, the brightness is random when using DALI dimming, disconnect AC (mains) and connect DC,the driver will enter the emergency escape lighting system; disconnect DC and connect AC (mains), the light brightness will return to the max. default DALI brightness.

### ■ DALI Setting Instructions

DALI parameters such as DALI address, dimming curve, min. brightness, max. brightness, power-on beightness, erro-system brightness, extended-fade time, address, fade time, fade rate, group and scene, can be set by Lifud master computer.

Note: FEIG NFC reader needs to work with the Lifud software Tool.

### ■ Structure & Dimensions (unit: mm)

Model	Overall Appearance (L*W*H)	Distance Between 2 Positioning Holes (L)	Diameter of Positioning Hole (D)
LF-FSD150YA(Internal)	355*30*22 mm	345 mm	4.2 mm

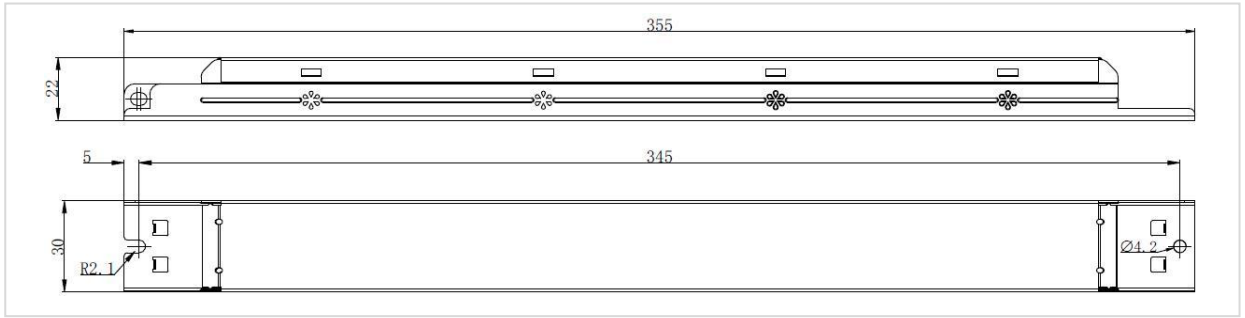

Model	Overall Appearance (L*W*H)	Distance Between 2 Positioning Holes (L)	Diameter of Positioning Hole (D)
LF-FSD150YA(External)	381.8*34.4*23.2 mm	345mm	4.2 mm

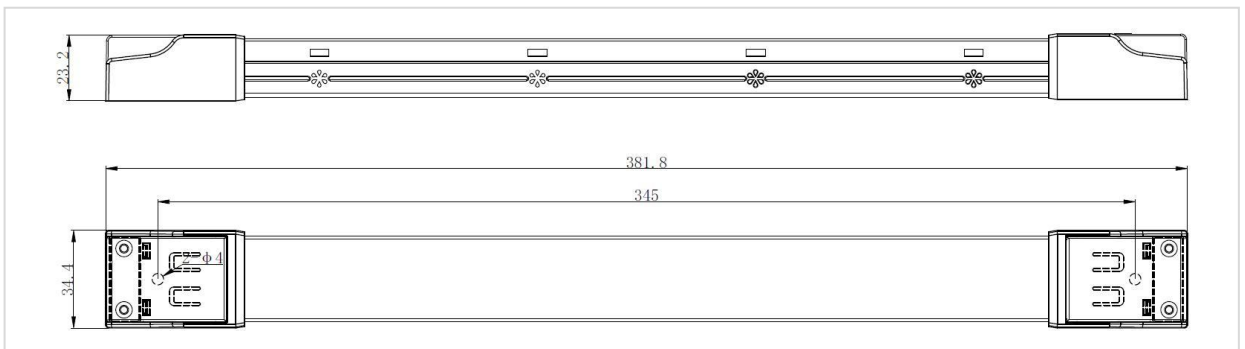

Remark: End caps should be purchased separately and shipped as accessories.

**■ Packaging Specifications**

Model	LF-FSD150YA
Carton Size	385*285*210mm (L*W*H)
Quantity	6 pcs/layer; 6 layers/ctn; 36 pcs/ctn
Weight	0.3 kg/pc; 11.48 ± 5% kg/ctn

**■ Transportation and Storage**

**1. Transportation**

- Suitable transportation means: vehicles, boats and aeroplanes.
- In transit, it is necessary to prepare awnings for rain or sun protection. Moreover, please keep civilized loading and unloading to prevent the vibration or impact of LED driver as much as possible.

**2. Storage**

- The storage of LED driver shall conform to the standard of Class I environment. When using LED drivers which have been stored for more than 6 months, please re-test them firstly. Do not use them unless they are tested to be qualified.

**Cautions**

- Please use Lifud LED driver according to its parameters in the specification, otherwise the LED driver may malfunction.
- Using any incompatible light fixtures or those that have not been certified may cause fire, explosion or other risks.
- Man-made damage is beyond the scope of Lifud warranty service.

Remark: Lifud Tecnology Co., Ltd. reserves the right to interpret any contents of this specification.