

**PRODUCT FEATURES**

- ◆ Input voltage: 100~240Vac;
- ◆ Surge protection: 4KV line-line, 6KV line-earth;
- ◆ Multiple protection: SCP, OVP;
- ◆ IP65
- ◆ 5 years warranty.

APPLICATION

- ◆ Suitable for industrial, explosion-proof lighting

DESCRIPTION

The MEP-040 series is a 40W constant current LED drive power supply with an input voltage range of 100~240Vac, high power factor and low THD, adjustable output current (potentiometer adjustment), and lout adjustable range 0.6-1.2A. It has input under voltage protection, lightning protection, output over voltage protection, and short circuit protection to ensure the high reliability of the product. This series of products has a compact structure and is designed for explosion-proof lights, high bay lights, and tunnel lights.

Model	Input voltage (Vac)	Max Output Power (W)	Output Voltage Range (Vdc)	Full-power Output Voltage Range (V)	Full Power Current Adjustable Range (A)	Default Output Setting (A)	Typ Efficiency	THD	Power Factor	
									120Vac	230Vac
MEP-040V058	100~240	40	28-58	33-58	0.7-1.2	0.7	86%	< 10%	0.98	0.97

OPERATING AREA

Output Current Vs Load Voltage

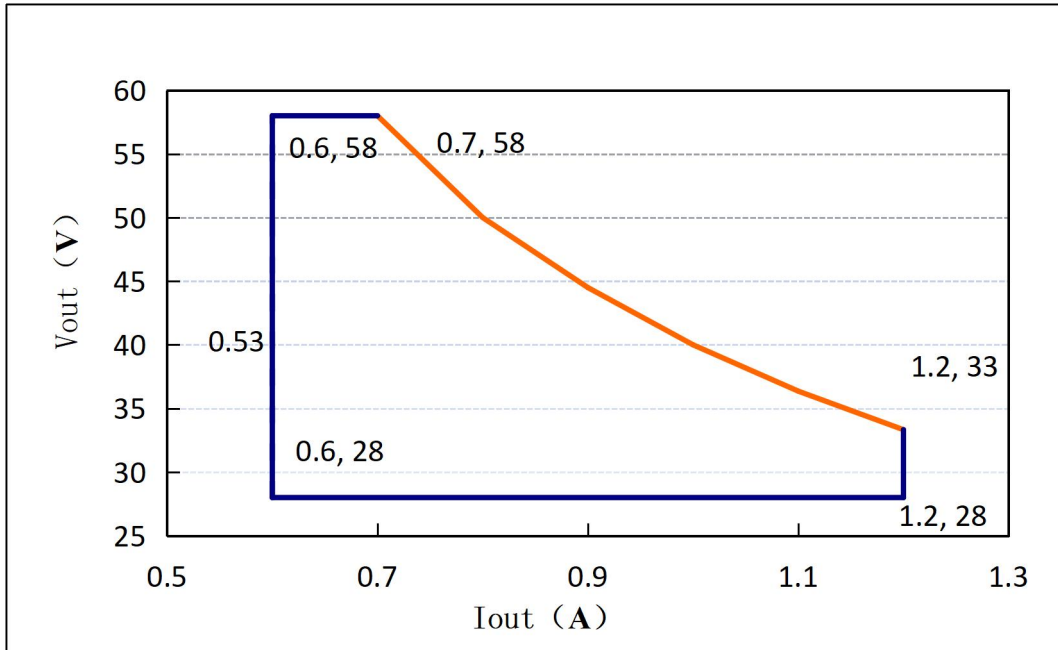

INPUT SPECIFICATIONS

Parameter	Min.	Typ.	Max.	Notes
Input Voltage	90Vac	100~240Vac	264Vac	
Input Frequency	47Hz	50/60Hz	63Hz	
Leakage Current	-	-	0.75mA	240Vac/50Hz
Input AC Current	-	-	0.7A	100~240Vac & 100% load
Inrush Current(I _{st})	-	-	0.1A2S	230Vac 输入, Ta=25°C (cold startup)
Power Factor	0.97	0.98	-	120vac/60Hz, 100% load
	0.95	0.97	-	230VAC/50Hz, 100% load
THD	-	6%	10%	120~240Vac, 100% load

OUTPUT SPECIFICATIONS

Parameter	Min.	Typ.	Max.	Notes
Output Current Tolerance	-5%I _{set}	-	5%I _{set}	100% load
Total Output Current Ripple (pk-pk)	-	8%	15%	20MHz BW, 100% Load& load is LED, ripple is different with difference LED load
Startup Overshoot Current	-	-	10%	120~240Vac & 100% Load, load is LED

No Load Output Voltage(V)	-	-	80V	
No load power consumption	-	-	2W	
Line Regulation	-	-	±3%	25°C±10°C ambient temperature, input voltage changes from 120Vac to 240Vac
Load Regulation	-	-	±3%	25°C±10°C ambient temperature, 230Vac input voltage, load changes from 60% to100%
Turn-on Delay Time	-	0.5S	1S	120Vac, 100% load
	-	0.5S	1S	230Vac, 100% load

GENERAL SPECIFICATIONS

Parameter	Min.	Typ.	Max.	Notes
Efficiency@120Vac I _o =0.7 I _o =1.2	84% 82%	86% 84%	-	25°C±10°C ambient temperature, 100% load
Efficiency@230Vac I _o =0.7 I _o =1.2	84% 83%	86% 85%	-	25°C±10°C ambient temperature, 100% load
Input to output dielectric strength voltage	-	3750Vac	-	60S, ≤10mA
Input to ground dielectric strength voltage	-	1600Vac	-	60S, ≤10mA
Output to ground dielectric strength voltage	-	1600Vac	-	60S, ≤10mA
Grounding Resistance	-	-	0.1Ω	25A/60S
Insulation Resistance	50MΩ	-	-	500Vdc/60S/25°C/70%RH
MTBF	-	200000hours	-	25°C±10°C ambient temperature, 230Vac,80% load (MIL-HDBK-217F)
Lifetime	-	50000 hours	-	230Vac&100% load,70°C case temperature, refer to lifetime VS Tc curve for details
Operating Case Temperature for Safety T _{c_s}	-40°C	-	85°C	
Operating Case Temperature for Warranty T _{c_w}	-40°C	-	70°C	5 years warranty Humidity: 10% to 95% RH
Storage Temperature	-40°C	-	+85°C	Humidity: 10% to 95% RH
Dimensions (L×W×H)mm	ø75×32mm			
Net Weight	250±50g/PCS			
Package	310x220x295mm			

SAFETY STANDARDS

Safety Category	Country / Territory	Standards
CCC	China	GB19510.1, GB19510.14
CE	Europe	EN61347-1, EN61347-2-13
CB	CB Countries	IEC61347-1, IEC61347-2-13
UL	USA	UL 8750, UL 1310(Class 2 Power Units), UL 1012
CUL	Canada	CSA C22.2 No.107.1-01, CSA C22.2 No.223-M91 (Power Supplies With Extra-Low-Voltage Class 2 Outputs)
KC	South Korea	K61347-1, K61347-2-13, K62384
PSE	Japan	J61347-1, J61347-2-13
SAA	Australia	AS/NZS IEC 61347-2-13
		AS/NZS 61347.1

EMC COMPLIANCE

EMC Category	Country / Territory	Standards
CCC	China	GB 17743, GB 17625.1
CE	Europe	EN 55015, EN 61000-3-2, EN 61000-3-3
		EN61000-4-2,3,4,5,6,8,11
		IEC 61547
KC	South Korea	K61547
		K00015
PSE	Japan	J55015
FCC	USA	FCC part 15

INRUSH CURRENT WAVEFORM

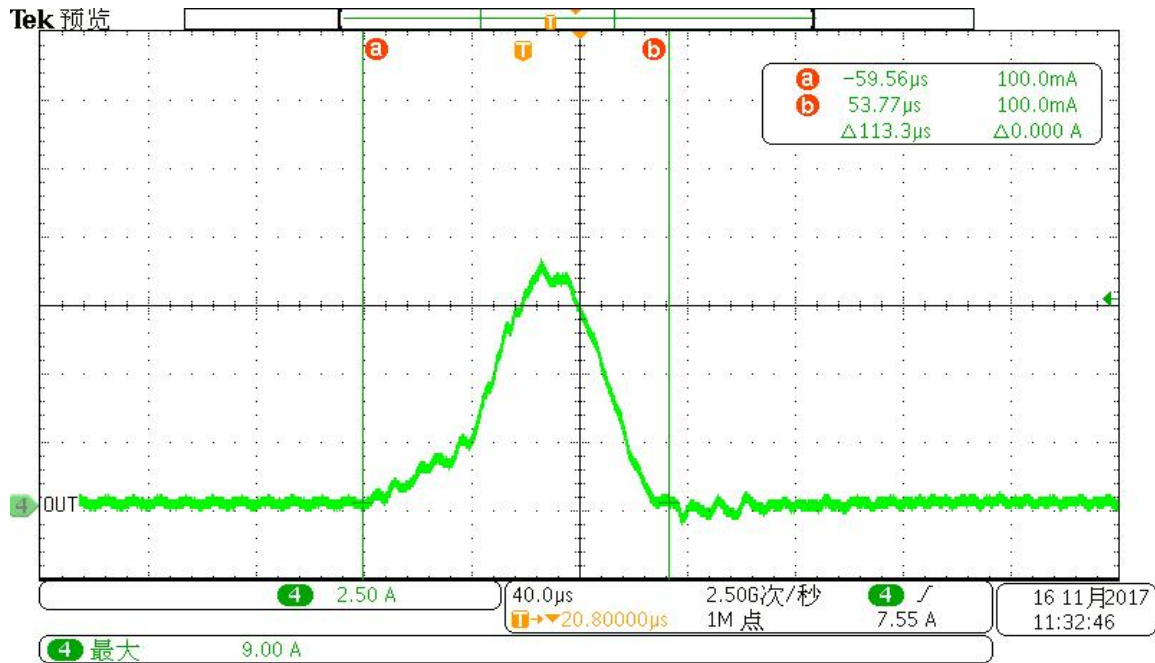

DERATING CURVE

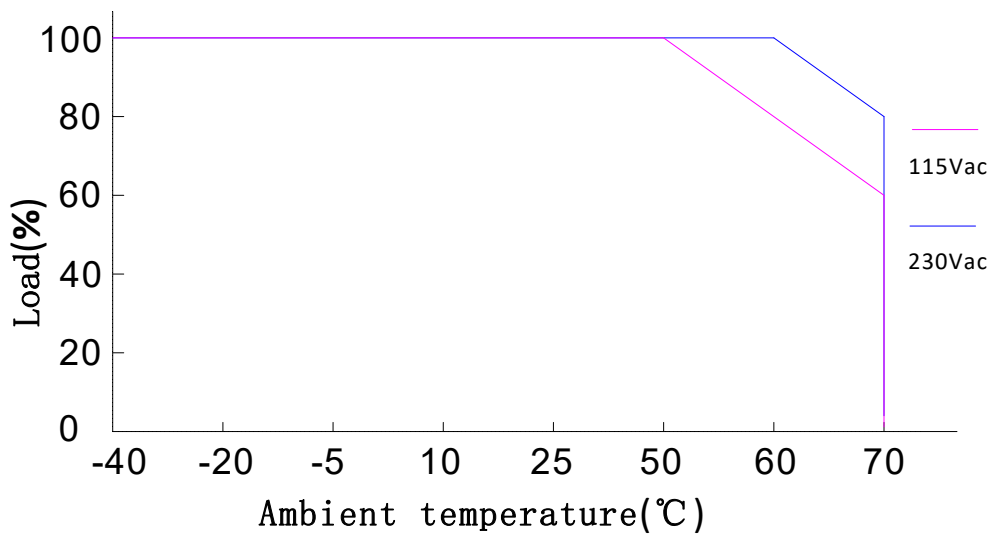

OUTPUT POWER VS INPUT VOLTAGE

Po/Pmax VS Input Voltage

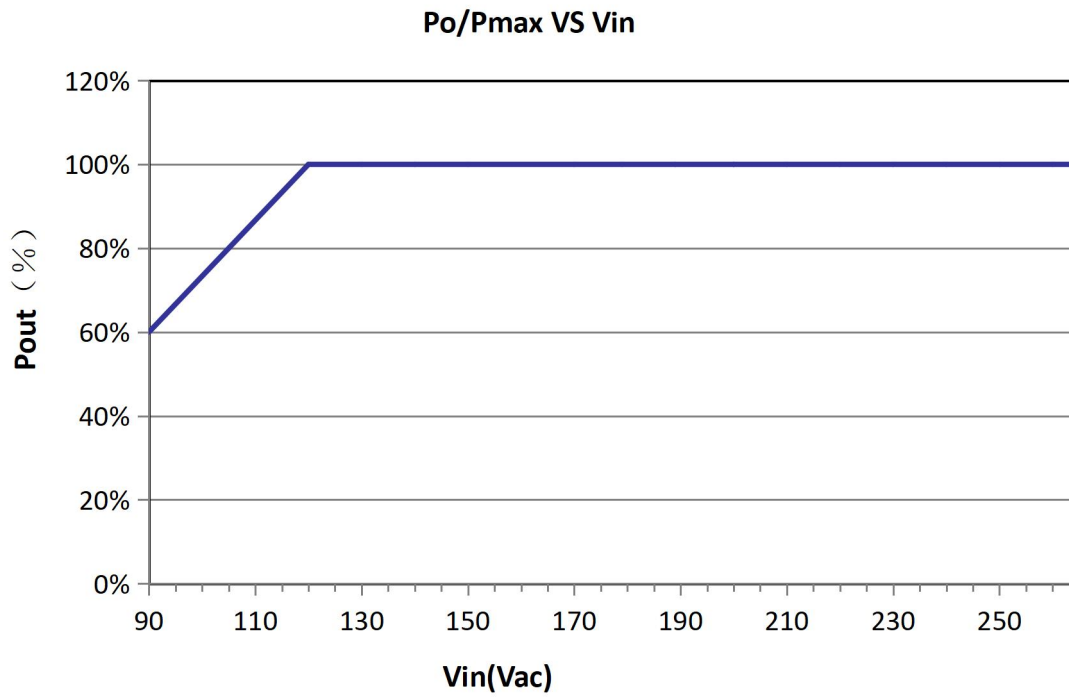

LIFETIME VS CASE TEMPERATURE

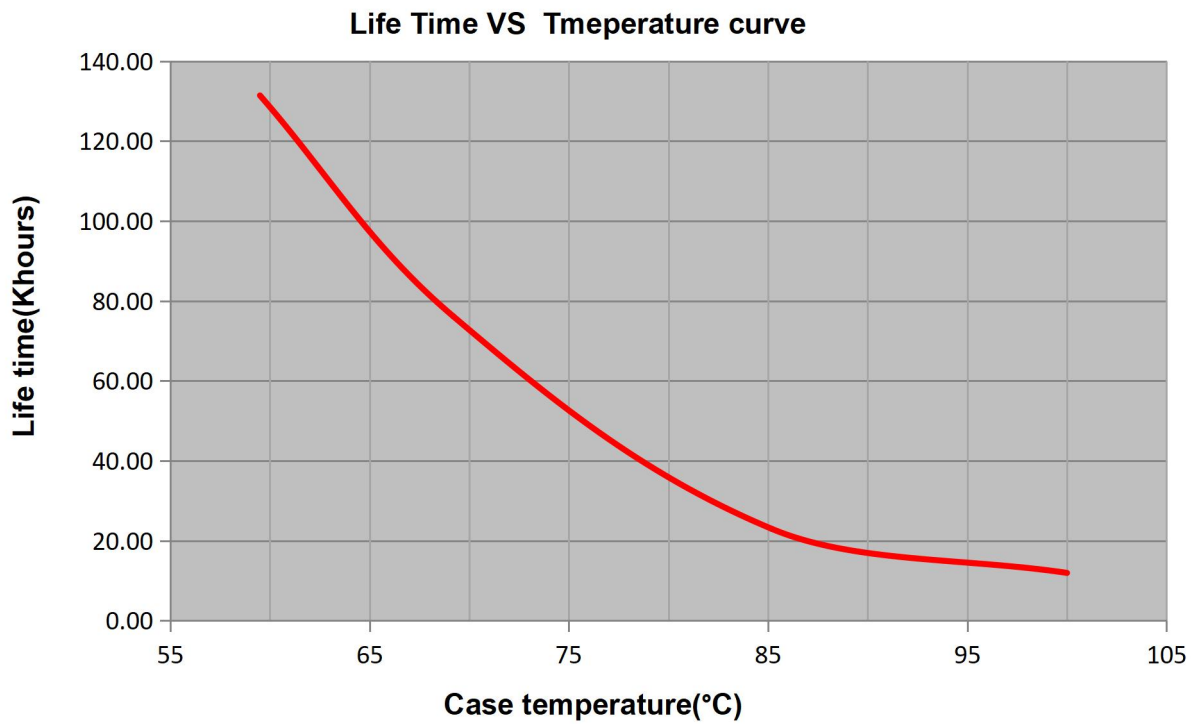

EFFICIENCY VS LOAD

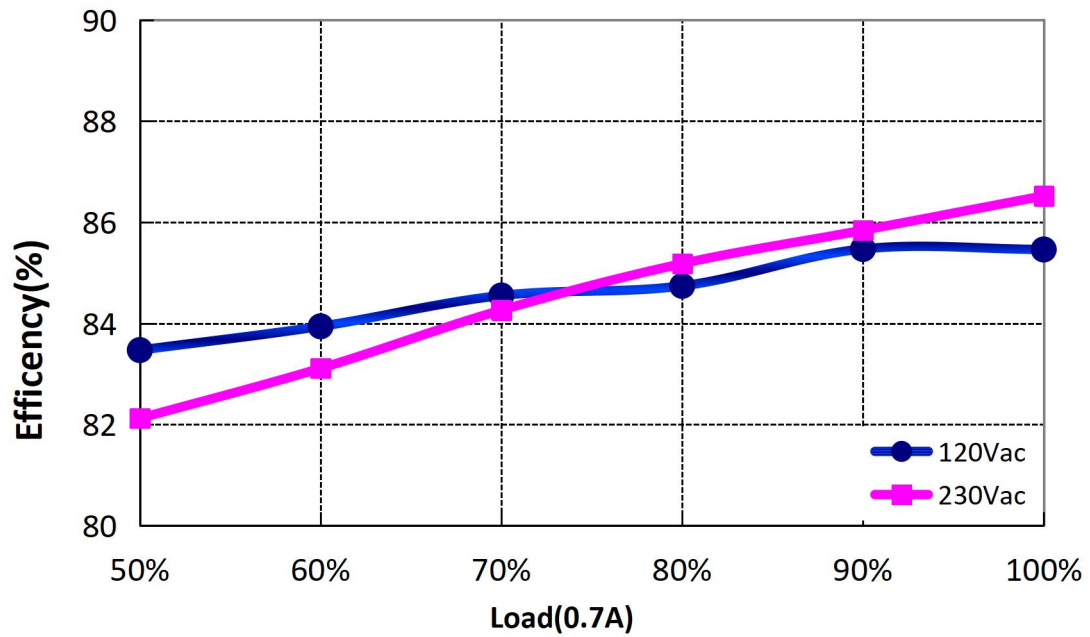

POWER FACTOR VS LOAD

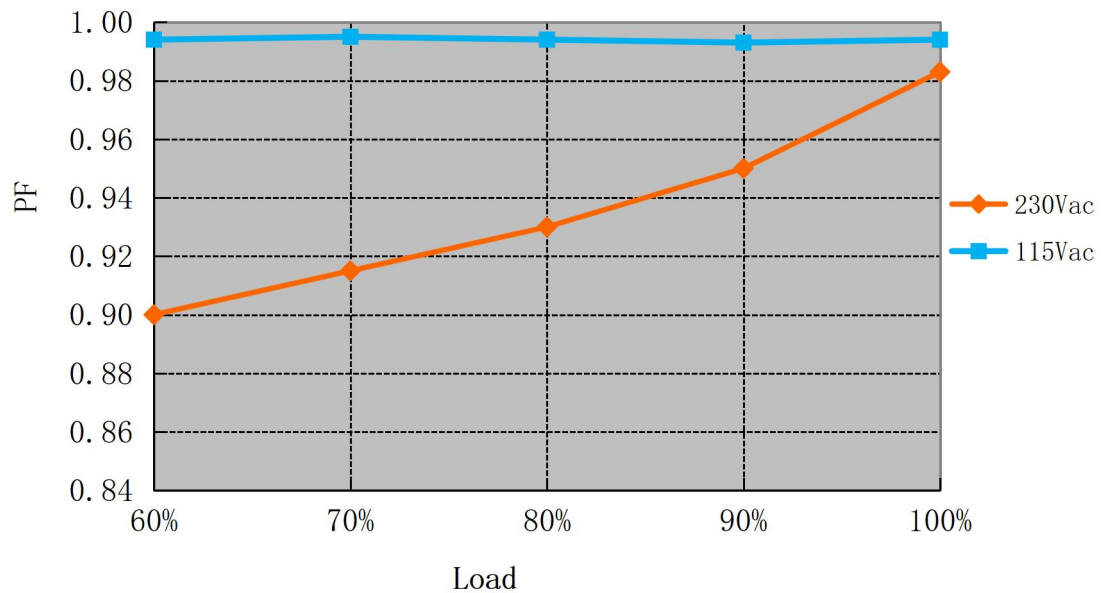

TOTAL HARMONIC DISTORTION

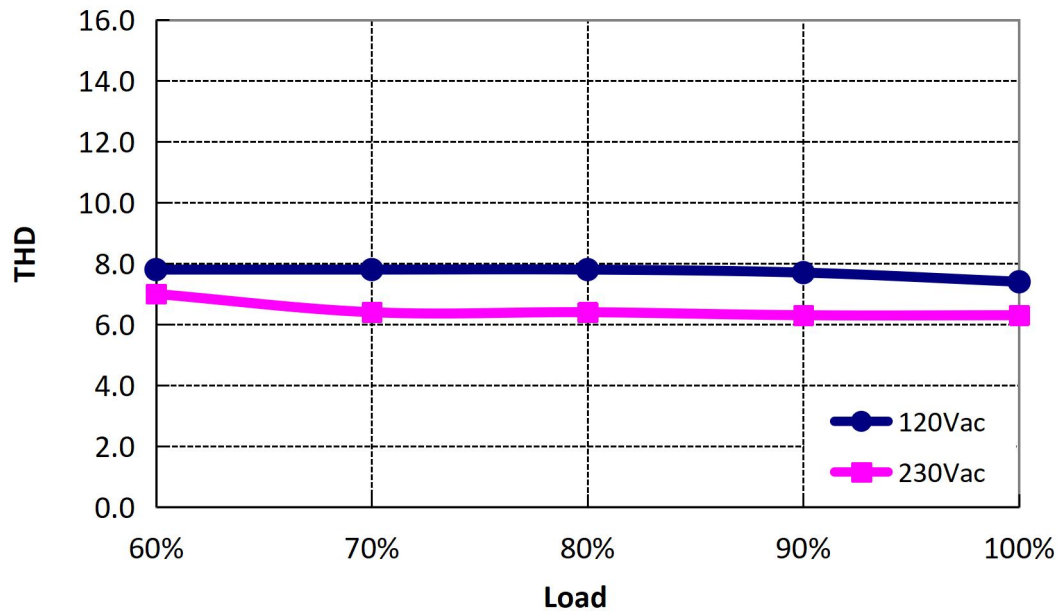

PROTECTIONS

Parameter	Notes
Over Temperature Protection	Decreases output current, returning to normal after over temperature is removed.
Short Circuit Protection	The input power shall decrease when the output rail short, the power supply shall not be damaged.
Over Voltage Protection	Run into protection model when output voltage exceeds limit, and return to normal when the fault

MECHANICAL OUTLINE

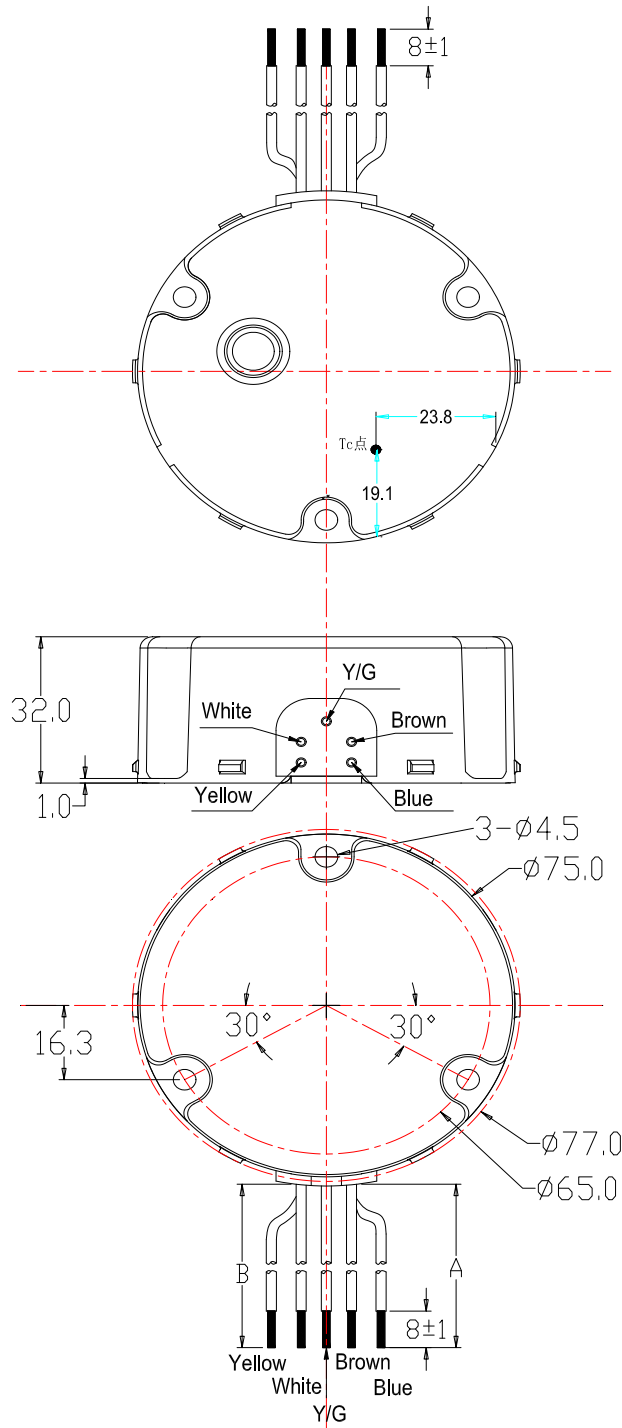

Wire	Specification	Note
Input L wire brown	UL3398 18AWG L=180 -20 +25mm	
Input N wire blue	UL3398 18AWG L=180 -20 +25mm	
Input earth wire yellow-green	UL3239 18AWG L=180 -20 +25mm	
"+" wire white	UL3239 18AWG L=180 \pm 20mm	
"-" wire yellow	UL3239 18AWG L=180 \pm 20mm	

Label

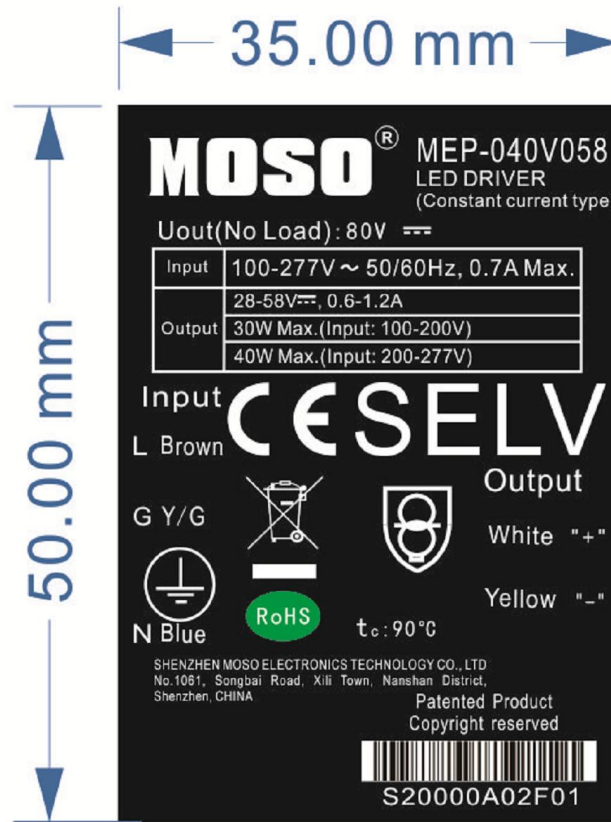

REVISION HISTORY

Version	Description of Change		Date	Notes
	Before	Now		
A.1	—	Datasheets Release	2020-09-22	