

Product Overview

NSHT30 is a relative humidity and temperature sensor with I²C Interface. It is a CMOS-MEMS sensor chip based on NOVOSENSE's new humidity and temperature platform. NSHT30 integrated a capacitive-based relative humidity sensor, a CMOS temperature sensor, a signal processor and a high speed I²C interface in a single chip and packaged in a small DFN package. The outline of the DFN package is only 2.5 mm in length, 2.5 mm in width and 0.9 mm in height. This allows the NSHT30 to be more widely integrated into a variety of applications. In addition, the I²C interface with two distinctive and selectable I²C addresses and communication speeds up to 1 MHz, the wide supply voltage range from 2 V to 5.5 V, makes the NSHT30 more compatible in various application environments.

Besides, the NSHT30 includes new integrated digital feature with programmable interrupt thresholds to provide alerts and system wake-up without requiring a microcontroller to continuously monitoring the system.

Key Features

- Fully calibrated and linearized
- Relative humidity and temperature compensated digital output
- Wide supply voltage range, from 2 V to 5.5 V
- Typical accuracy of $\pm 3\%$ RH and $\pm 0.3\text{ }^\circ\text{C}$ for NSHT30
- I²C Interface with communication speeds up to 1 MHz
 - Two selectable addresses
 - Data protection with CRC checksum
- 8-Pin DFN package
- RoHS & REACH qualified

Applications

- Washer & dryer
- Smart thermostats and room monitors
- White goods
- Printers
- Humidifier/dehumidifier
- Air quality monitoring
- Wireless sensor
- Home appliances

Device Information

Part Number	Package	Body Size
NSHT30-QDNR	DFN (8)	2.5mm × 2.5mm × 0.9mm

Typical Application Circuit

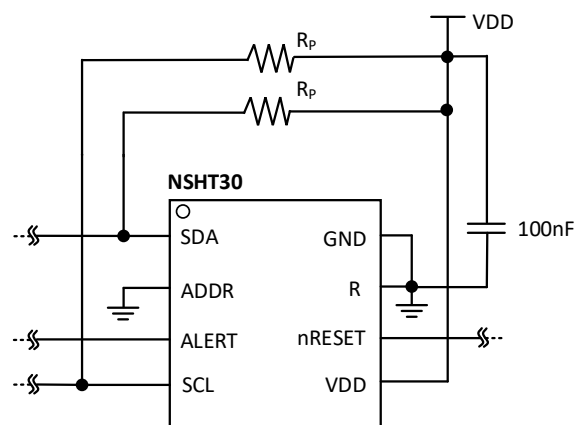

Figure 1. Typical application circuit

INDEX

1. PIN CONFIGURATION AND FUNCTIONS	4
1.1. POWER PINS	4
1.2. SERIAL CLOCK AND SERIAL DATA (SCL, SDA)	4
1.3. ADDR PIN	5
1.4. ALERT PIN	5
1.5. NRESET PIN	5
2. ABSOLUTE MAXIMUM RATINGS	6
3. ESD RATINGS	6
4. RECOMMENDED OPERATING CONDITIONS.....	6
5. SPECIFICATIONS.....	7
5.1. ELECTRICAL CHARACTERISTICS.....	7
5.2. SUPPLY CURRENT CHARACTERISTICS – 5V SUPPLY	7
5.3. TIMING SPECIFICATION FOR THE SENSOR SYSTEM	8
5.4. I ² C TIMING CHARACTERISTICS	8
5.5. HUMIDITY SENSOR SPECIFICATION.....	9
5.6. TEMPERATURE SENSOR SPECIFICATION.....	9
6. OPERATION AND FUNCTION DESCRIPTION.....	11
6.1. POWER-UP AND COMMUNICATION START	11
6.2. STARTING A MEASUREMENT.....	11
6.3. SINGLE SHOT DATA ACQUISITION MODE.....	11
6.3.1 MEASUREMENT COMMANDS FOR SINGLE SHOT DATA ACQUISITION MODE	12
6.3.2 READOUT OF MEASUREMENT RESULTS FOR SINGLE SHOT MODE	12
6.4. PERIODIC DATA ACQUISITION MODE	12
6.4.1 MEASUREMENT COMMANDS FOR PERIODIC DATA ACQUISITION MODE.....	13
6.4.2 READOUT OF MEASUREMENT RESULTS FOR PERIODIC MODE	13
6.4.3 BREAK COMMAND / STOP PERIODIC DATA ACQUISITION MODE.....	14
6.5. RESET	14
6.5.1. SOFT RESET / RE-INITIALIZATION.....	14
6.5.1. RESET THROUGH THE NRESET PIN	14
6.5.2. HARD RESET	14
6.6. HEATER.....	15
6.7. STATUS REGISTER.....	15
6.7.1. READ STATUS REGISTER	15
6.7.2. CLEAR STATUS REGISTER.....	16
6.8. CHECKSUM CALCULATION.....	16
6.9. CONVERSION OF SIGNAL OUTPUT	17
7. ACTIVATION AND DEACTIVATION OF THE ALERT MODE	18
7.1. ACTIVATION AND DEACTIVATION OF THE ALERT MODE	18
7.2. ALERT MODE LIMITS.....	18
7.2.1. DATA FORMAT FOR THE ALERT LIMITS.....	18
7.2.2. DEFAULT VALUES FOR THE ALERT LIMITS.....	19
7.2.3. ALERT MODE COMMANDS.....	19

7.2.4. TYPICAL PROCEDURE TO CALCULATE THE LIMITS20

7.2.5. TYPICAL PROCEDURE TO CHANGE THE ALERT CONDITION.....20

7.3. FURTHER CONDITION THAT CAN RAISE AN ALERT..... 20

8. APPLICATION NOTE 21

8.1. TYPICAL APPLICATION CIRCUIT 21

8.2. SOLDERING REFLOW 21

9. PACKAGE INFORMATION..... 22

9.1. DFN (8) PACKAGE..... 22

10. ORDER INFORMATION 23

11. MARKING..... 23

12. TAPE AND REEL INFORMATION 24

13. REVISION HISTORY 25

1. Pin Configuration and Functions

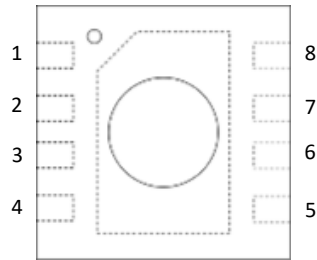

Figure 1.1 NSHT30 Package

Table 1.1 NSHT30 Pin Configuration and Description

NSHT30 Pin No.	Symbol	Function Description
1	SDA	Serial data pin; a pullup resistor needs to be connected
2	ADDR	Address pin; connect to either logic high or low, do not leave floating
3	ALERT	Indicates alarm condition; must be left floating if unused
4	SCL	Serial clock pin; a pullup resistor needs to be connected
5	VDD	Supply voltage, 2.0 V to 5.5 V
6	nRESET	Reset pin, active low; if not used it is recommended to be left floating
7	R	No electrical function; to be connected to GND
8	GND	Ground

1.1. Power Pins

As shown in the Typical application Circuit ([Figure 1.2](#)), the power supply pin must be connected to a 100 nF capacitor. The capacitor should be as close to the sensor as possible. Capacitance plays a coupling role in the whole circuit. For the voltage information, please refer to [Part 2](#) in this document.

1.2. Serial Clock and Serial Data (SCL, SDA)

The NSHT30 operates as a Slave in I²C communication and must be queried by a Master. For the I²C connection between the Master (microcontroller) and NSHT30, the SCL pin serves as the clock. Namely, the SDA pin is involved in data transfer between the microcontroller and sensor.

The user may freely choose a communication frequency range between 0 and 1000 kHz. Low-frequency communication (< 400kHz) should conform to the I²C fast mode standard. Communication frequencies of up to 1 MHz are supported if the specifications in [Part 5.4](#) are followed.

SCL and SDA are open-drain I/Os with diodes connected to VDD and VSS inside the chip. They should be connected to VDD with external pull-up resistors as shown in [Figure 1.2](#). As devices on the I²C bus can only drive a line to ground, the external pull-up resistors (such as R_p=5 kΩ) are needed to get High level.

Bus capacitance and communication frequency are two major factors that affect the value of pull-up resistors. Detail can be found in Section 7.1 of NXP's I²C Manual. Be careful that pull-up resistors may be integrated inside the microcontrollers. They should be taken into consideration.

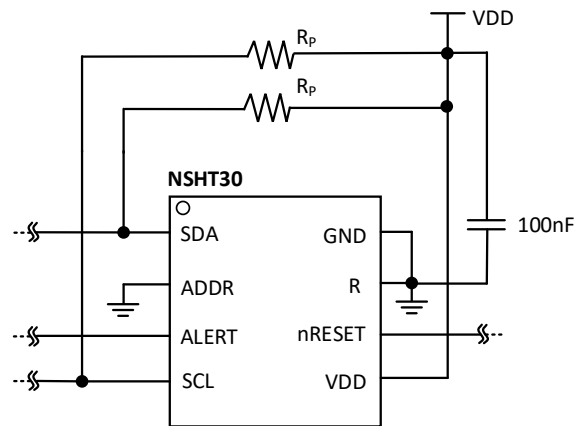

Figure 1.2. Typical application circuit

1.3. ADDR Pin

NSHT30 has two selectable addresses (see [Table 1.2](#)), which is realized by different wiring method of the ADDR pin. It has two connection states: logic high and logic low. Switching voltage on the ADDR pin from the logic Low level to the logic High level can dynamically change the address of the sensor. Therefore, more than two NSHT30 can be connected on the same bus. But during I²C communication, the level on the ADDR pin should be kept constant until the communication is completed.

If dynamic switching address is preferred, a separate ADDR line should be connected between the microcontroller and NSHT30.

Pay attention that the I²C address mentioned here is the higher 7 bits of the 8 bits address byte at the beginning of I²C read or write. The last bit indicates the read or write direction of I²C communication. As shown in [Table 1.2](#) and [Figure 1.2](#), the wiring of ADDR default address is connected to logic low level. The ADDR pin must not be left floating.

Table 1.2. I²C device addresses

NSHT30	7 bits I ² C address Hex.	Condition
I ² C address A	44	ADDR (pin 2) connected to logic low
I ² C address B	45	ADDR (pin 2) connected to logic high

1.4. ALERT Pin

The ALERT pin can be connected to the interrupt pin of a microcontroller. The output voltage of the pin is determined by the reading value of RH/T and the limits. The specific function description is explained in a separate [section 7](#). This pin must remain floating when not in use. When the alert condition is triggered, the pin is switched from low level to high level. The maximum driving loads can be found in the [Electrical Characteristics](#). Take notice that the current flowing through the ALERT pin will cause the self-heating of the sensor. One way to prevent self-heating is to use the ALERT pin only as switch trigger with the help of an additional transistor.

1.5. nRESET Pin

The sensor can be reset through nReset pin with a logic low pulse. To trigger a reliably reset of the sensor, the pulse duration should be at least 1 μ s. A more detail explanation is given in [Section 6.5](#). When the reset function is not used, the pin should be kept floating as the nReset pin is internally connected to VDD with a pull up resistor of R=50 k Ω (typ.)

2. Absolute Maximum Ratings

Parameters	Symbol	Min	Typ	Max	Unit
Power Supply Voltage	VDD	-0.3		6	V
Input Voltage	SDA, ADDR, ALERT, SCL, nRESET	-0.3		VDD+0.3	V
Storage Temperature	T _{stg}	-40		150	°C
Operating Temperature	T _{op}	-40		125	°C
Operating Humidity	H _{op}	0		100	%RH
Junction temperature	T _{jun}			150	°C

3. ESD Ratings

Parameters	Symbol	Value	Unit
V(ESD)Electrostatic discharge	Human-body model (HBM), per ESDA/JEDEC JS-001	±4000	V
	Charged-device model (CDM), per ESDA/JEDEC JS- 002	±2000	

4. Recommended Operating Conditions

Parameters	Symbol	Min	Typ	Max	Unit
Power Supply Voltage	VDD	2	5	5.5	V
Temperature Operating Range	T _{OR}	0		80	°C
Relative Humidity Operating Range	RH _{OR}	20		80	%RH

The recommended operating environment of NSHT30 should be controlled within the temperature range of 0-80 °C, and the relative humidity range of 20%RH - 80% RH, because its performance is the best at this range. If the sensor is exposed outside of the recommended operating environment for a long time, especially when the relative humidity is less than 3%RH or more than 80% RH, the offset of the relative humidity may increase temporary. When the sensor returns to the normal temperature and relative humidity operating range, it will slowly return to the initial state. Pay attention that long-term exposure to extreme conditions may accelerate the aging of the sensor, and the process of sensor self-recovery is slow. In order to ensure the stable operation of the NSHT30, it is recommended to use it in the recommended operation environment.

5. Specifications

5.1. Electrical Characteristics

Unless otherwise noted, Typical values are at VDD =+2V to +5.5V, Ta = 25°C.

Parameters	Symbol	Condition	Min	Typ	Max	Unit	Comments
Supply voltage Range	VDD		2.0	5	5.5	V	
Pull up resistor	R _p			5		kΩ	Pull Up Resistor for SDA/SCL
Heater power	P _{heater}	Heater running		39		mW	Depending on the supply voltage
Driving capability of ALERT	D _{Alert}			1.5*VDD		mA	

5.2. Supply Current Characteristics – 5V Supply

Unless otherwise noted, Typical values are at VDD = 5V, Ta = 25°C.

Parameters	Symbol	Condition	Min	Typ	Max	Unit	Comments
Supply current	NSHT30						
	I _{DD}	idle state (single shot mode) T=25°C		0.3	1	μA	Current when sensor is not performing a measurement during single shot mode
		idle state (periodic data acquisition mode)		160		μA	Current when sensor is not performing a measurement during periodic data acquisition mode
		Measuring		700	900	μA	Current consumption while sensor is measuring
		Average		3.2		μA	Current consumption (operation with one measurement per second at lowest repeatability, single shot mode)

5.3. Timing Specification for The Sensor System

Parameters	Symbol	Condition	Min	Typ	Max	Unit	Comments
Power-up time	t_{PU}	After hard reset, $V_{DD} \geq V_{POR}$		0.5	1	ms	Time between VDD reaching V_{POR} and sensor entering idle state
Soft reset time	t_{SR}	After soft reset		0.5	1	ms	Time between ACK of soft reset command and sensor entering idle state
Duration of reset pulse	t_{RESETN}		1			μs	
Measurement duration	$T_{MEAS,L}$	Low repeatability		4.5	5.5	ms	The three repeatability modes differ with respect to measurement duration, noise level and power consumption
	$t_{MEAS,M}$	Medium repeatability		5.5	6.5	ms	
	$t_{MEAS,H}$	High repeatability		11.5	12.5	ms	

5.4. I²C Timing Characteristics

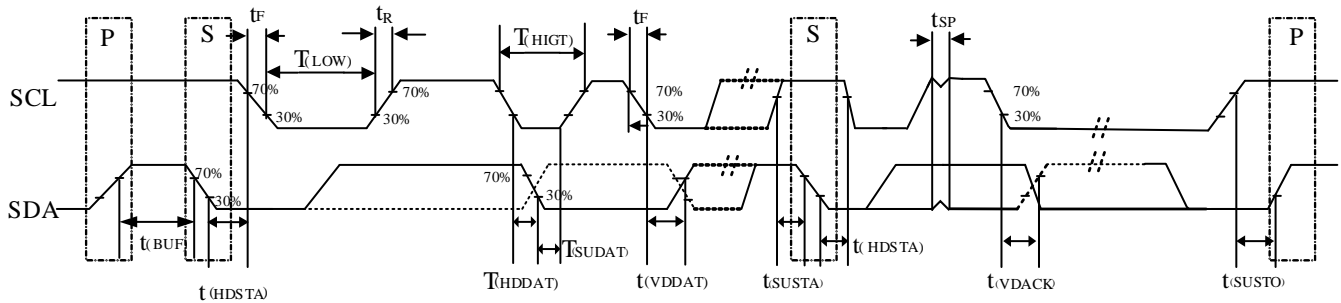

Figure 5.1 I²C Timing Diagram

Parameters	Symbol	Conditions	Min	Max	Unit	Comments
SCL operating frequency	F_{SCL}		0.001	1000	kHz	
Bus-free time between STOP	$t_{(BUF)}$		1300		ns	
Hold time after repeated START	$t_{(HDSTA)}$	After this period, the first	0.24		μs	
Repeated START condition	$t_{(SUSTA)}$		0.26		μs	
STOP condition setup time	$t_{(SUSTO)}$		0.26		μs	
Data hold time	$T_{(HDDAT)}$		0	250	ns	Transmitting data
					ns	Receiving data
Data setup time	$T_{(SUDAT)}$		100		ns	
SCL clock low period	$T_{(LOW)}$		0.53		μs	
SCL clock high period	$T_{(HIGH)}$		0.26		μs	
SCL/SDA fall time	t_F			300	ns	
SCL/SDA rise time	t_R			300	ns	
SDA valid time	t_{VDDAT}			0.9	μs	

5.5. Humidity Sensor Specification

At Ta = 25°C and VDD = +2V to +5.5V, unless otherwise noted.

Humidity Sensor Specification							
Parameter	Symbol	Condition	Min	Typ	Max	Unit	Comment
Humidity Range	H_Range		0		100	%RH	
Resolution	H_Res.			0.01		%RH	
Accuracy	H_Acc.			±3	Figure 5.2	%RH	20%RH-80%RH
Repeatability	H_RepL.	Rep. Low		0.21		%RH	
	H_RepM.	Rep. Medium		0.12		%RH	
	H_RepH.	Rep. High		0.07		%RH	
Hysteresis	H_Hys.	VDD=5V		±1			@ 50 %RH
Response time	H_τ63%	VDD=5V		6		s	From 20%RH to 80%RH
Long Term Drift	H_Drift			0.2		%RH/yr	

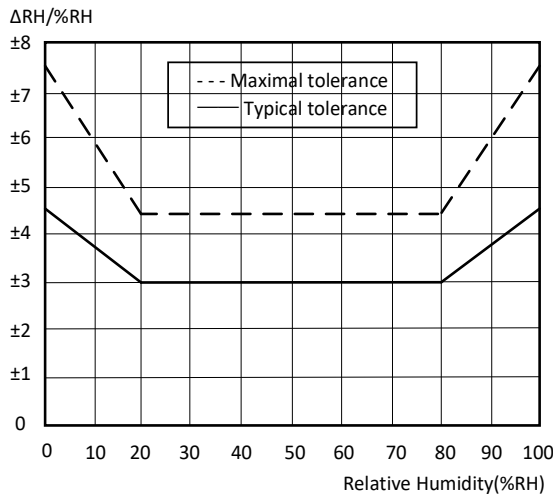

Figure 5.2 Tolerance of RH at 25°C for NSHT30

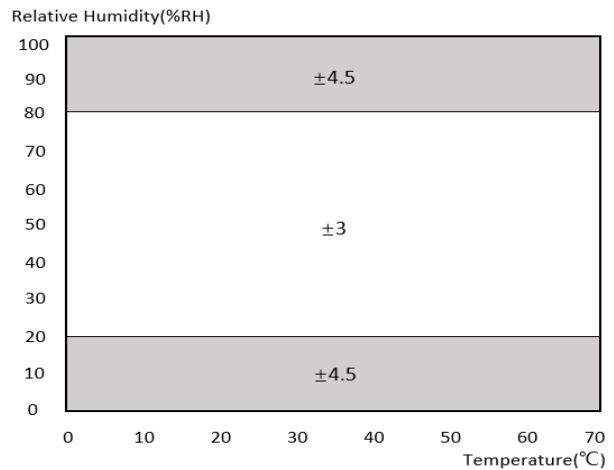

Figure 5.3 Typical tolerance of RH over T for NSHT30

5.6. Temperature Sensor Specification

At VDD = +2V to +5.5V, unless otherwise noted.

Temperature Sensor Specification							
Parameter	Symbol	Condition	Min	Typ	Max	Unit	Comment
Temperature Range	T_Range		-40		125	°C	
Resolution	T_Res.			0.0625		°C	
Accuracy	T_Acc.			±0.3	Figure 5.4	°C	0 °C - 80 °C
Repeatability	T_RepL.	Rep. Low		0.08		°C	
	T_RepM.	Rep. Medium.		0.06		°C	
	T_RepH.	Rep. High		0.04		°C	
Response time	T_τ63%	VDD=5V		2		s	From 25°C to 100°C
Long Term Drift	T_Drift			0.01		°C/yr	

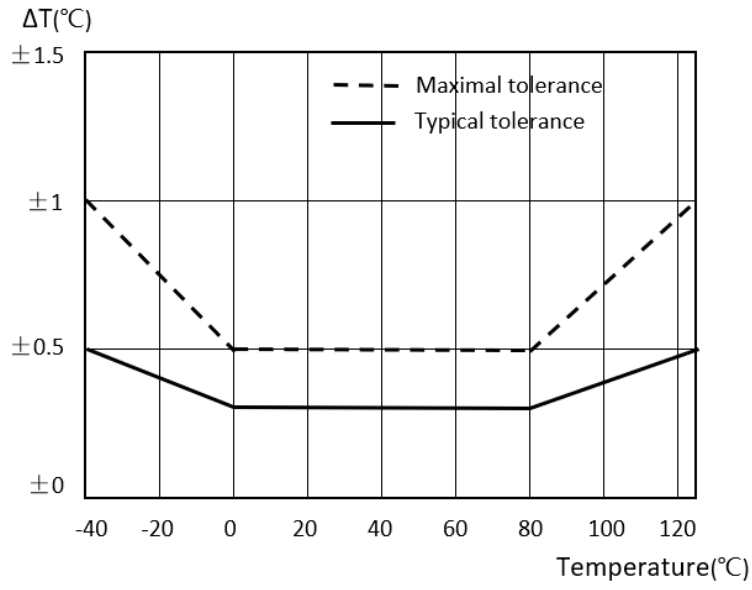

Figure 5.4 Temperature tolerance for NSHT30

6. Operation and Function Description

The frequency of NSHT30 in I²C fast mode can reach up to 1000 kHz. Users can learn more details about I²C protocol from NXP I²C-bus specification.

The NSHT30 uses a 16-bit command and data space. In addition, the existence of CRC checksum ensures the correctness of data, and further improves the reliability of communication. The data sent and received by the sensor always contains an 8-bit CRC byte after every 16-bit data. Details of the checksum calculation is given in [Part 6.8](#).

When the master writes data to the sensor, the accuracy of the checksum byte must be ensured, because NSHT30 can only receive the data with the correct checksum. When the master reads the sensor, it is left to the master to read and process the checksum. But when data is read from the NSHT30 by the master, users can choose whether to check the checksum byte with the received data or not.

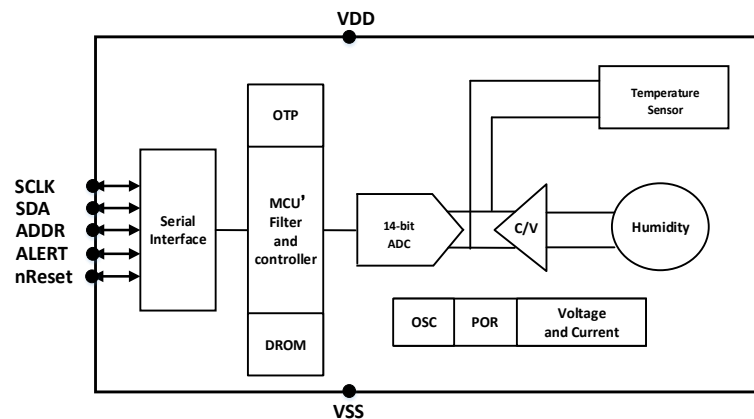

Figure 6.1 Functional block diagram of the NSHT30

6.1. Power-Up and Communication Start

The necessary condition for the sensor to start power-up is that the supply voltage reached the power-up threshold voltage VDD_{POR} specified in the [Electrical Characteristics](#). After the sensor is powered up, it automatically enters the idle state, which is a state of low power consumption. The waiting time between the sensor power-up and the idle state is called t_{PU} . When the sensor enters the idle state, it means that the NSHT30 can receive commands from the master (microcontroller).

Once the corresponding command is sent, the sensor will perform measurement or communication. The START condition (S) and STOP condition (P) for each transmission sequence were defined in the I²C bus standard.

6.2. Starting a Measurement

The NSHT30 have two different measurement mode triggered by different measurement commands. To start a measurement, users should send a measurement sequence with a correspond measurement command. A measurement communication sequence is composed of a START condition, the I²C write header (7-bit I²C device address plus 0 as write bit), a 16-bit measurement command and a STOP condition. In I²C communication, Data are sent or received by byte. After the falling edge of the 8th SCL clock arrives, the NSHT30 will pull the SDA pin low as an ACK bit. The ACK bit serves as an indicator to show that the sensor has already received the byte data. As shown in [Table 6.1](#), it is a complete measurement cycle in Single Shot Data Acquisition Mode.

After receiving the complete measurement command, the NSHT30 starts to measure the humidity and temperature in the current environment. Detail of different measurement mode can be found in [Part 6.3](#) & [Part 6.4](#).

6.3. Single Shot Data Acquisition Mode

In single shot mode, after the sensor received the complete measurement sequence, it will start the measurement of temperature and relative humidity in the environment. Once the measurement is complete, the data of the measurement is updated in the sensor. Then, users can readout the data from the sensor with a reading sequence described in [Part 6.3.2](#). The data is made up of 6 bytes: 2 bytes of temperature data, 1 byte of temperature CRC checksum, 2 bytes of humidity data, and 1 byte of humidity CRC checksum (in this order). For detailed explanation of CRC, see [Section 6.8](#).

6.3.1 Measurement Commands for Single Shot Data Acquisition Mode

There are a variety of measurement commands can be selected in single shot mode. As shown as [Table 6.1](#), it gives different 16-bit measurement commands for single shot mode. The main differences between commands are repeatability (low, medium, high).

The setting of repeatability is an important factor that affects the measurement duration and the overall power consumption of the sensor. The measurement duration of different repeatability is given in [section 5.3](#).

Table 6.1. Measurement commands in single shot mode.

(Clear blocks are controlled by the microcontroller, grey blocks by the sensor).

Hex. code		Condition
MSB	LSB	Repeatability
24	00	High
	0B	Medium
	16	Low

e.g. 0x2400: high repeatability measurement

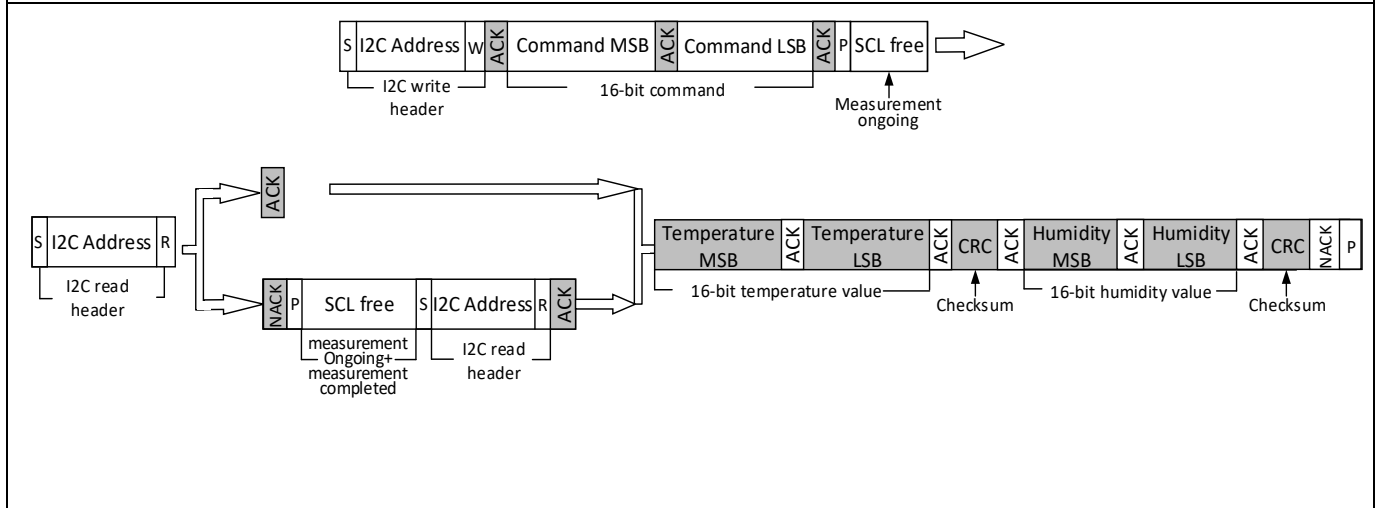

6.3.2 Readout of Measurement Results for Single Shot Mode

The process of readout the measurement results is start by sending the right I²C read header by the master. The right I²C read header is a byte data composed with I²C 7-bit address from bit7 to bit1 and the read direction in bit0. As mentioned previously, after completely received the measurement command, the sensor is in measurement status. If the sensor is still in measurement when received the read header, it will send a NACK to the master. In this situation, the master should stop the readout process and restart a new readout process. If the measurement is complete when received the read header, the sensor will send ACK to the master and start to send the measurement result.

The complete result is 6 bytes data. Master should send an ACK after received each of the first 5 bytes and a NACK and STOP for the 6th byte to receive the complete result and stop the communication.

After receiving a NACK, the sensor stops to transmit the data. It can be used after any data byte, if the I²C master does not want subsequent data (such as CRC bytes or the second measurement result).

There is a situation that the user only needs to read humidity and temperature data, and CRC is not required to verify the correctness of the data. It is suggested that users read the two temperature bytes and one CRC byte of data, but do not process the CRC data. Then after reading two humidity bytes, NACK can be used to abort the reading transmission.

6.4. Periodic Data Acquisition Mode

Periodic data acquisition mode is quite different with single shot mode. The sensor will conduct a periodic measurement and update the measurement result itself in this mode. The master can get the latest measurement result by sending the read data command.

The measurement result is also a 6 bytes data as mentioned previously. Users can send the break command to stop the periodic data acquisition mode of the sensor.

6.4.1 Measurement Commands for Periodic Data Acquisition Mode

As a mode of periodic data acquisition, 5 different periodic can be used, and there are 3 different repeatability choices for each periodic. Then, a total of 15 different measurement commands can be selected in periodic data acquisition mode. As shown in [Table 6.2](#), the corresponding 16-bit commands are listed. The periodic of each mode is described with mps (measurement per second).

Since the measurement periodic and the measurement duration time of the sensor are different in each periodic command. The average power consumption varies with the periodic mode command used.

The periodic data acquisition mode is active after receiving a complete 16-bit command list in [Table 6.2](#). The trigger sequence is composed of an I²C write header, and a 16-bit command in two bytes. The sensor will give an ACK after each byte.

When the sensor was already in a periodic mode, users are recommended to send the break command before sending the new measurement command. As the sensor may fail to process the new measurement command when it's in measurement duration. Detail information of break command can be found in [Part 6.4.3](#).

Table 6.2. Measurement commands for periodic data acquisition mode (Clear blocks are controlled by the microcontroller, grey blocks by the sensor). Note: At the highest mps setting self-heating of the sensor might occur.

Hex. code		Condition	
MSB	LSB	Periodic	Repeatability
20	32	0.5 mps	High
	24		Medium
	2F		Low
21	30	1 mps	High
	26		Medium
	2D		Low
22	36	2 mps	High
	20		Medium
	2B		Low
23	34	4 mps	High
	22		Medium
	29		Low
27	37	10 mps	High
	21		Medium
	2A		Low
e.g. 0x2737: 10 mps high repeatability			

6.4.2 Readout of Measurement Results for Periodic Mode

The master can acquire measurement data through the read data command shown in [Table 6.3](#). The master fetches the data of the sensor by sending a sequence to the sensor. The sequence is composed of a start condition, an I²C write header, the Read Data command, an I²C read header.

After receiving the right I²C read header, the sensor will give an ACK and the 6 bytes result. As mentioned in single mode, the master should give an ACK after each byte read of the first 5 bytes and use the NACK and P to stop the communication after the 6th byte is received.

Table 6.3. Read Data command (Clear blocks are controlled by the microcontroller, grey blocks by the sensor).

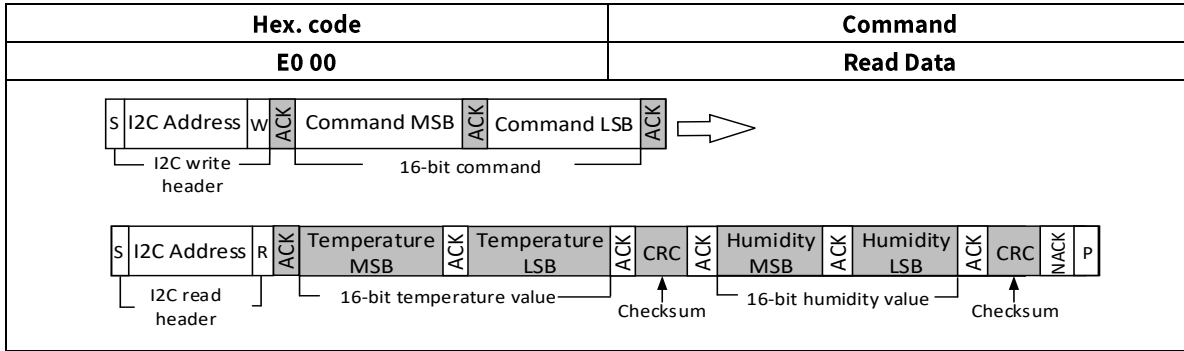

6.4.3 Break Command / Stop Periodic Data Acquisition Mode

The master can send the break command as shown in [Table 6.4](#) to exit the periodic data acquisition mode. After receiving the break command, the sensor will abort the ongoing measurement and enter the single shot idle mode. The shortest waiting time between the sensor quit Periodic mode and entered the idle mode needs 1 ms. It is recommended to stop the periodic data acquisition prior to sending another command (except Read Data command) using the break command.

Table 6.4. Break command (Clear blocks are controlled by the microcontroller, grey blocks by the sensor).

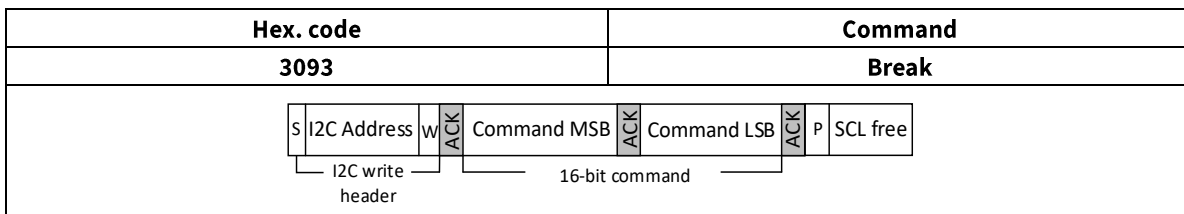

6.5. Reset

The NSHT30 system reset can be generated by delivering a command (soft reset) or by sending a pulse to the special reset pin (nReset pin). Moreover, a system reset is also generated internally during power-up. The sensor will not process commands during the reset procedure. The reset caused by the nReset Pin is a full reset of the sensor like repower the sensor. It's a better choice than removing the power supply to get a full reset of the sensor.

6.5.1. Soft Reset / Re-Initialization

When the NSHT30 is not performing any operation (in idle state), users can send a soft reset command to the sensor. It can trigger a reset of the system controller in the sensor and will restore and reload the calibration data in memory. The command to trigger soft reset are shown in [Table 6.5](#).

Table 6.5. Soft reset command (Clear blocks are controlled by the microcontroller, grey blocks by the sensor).

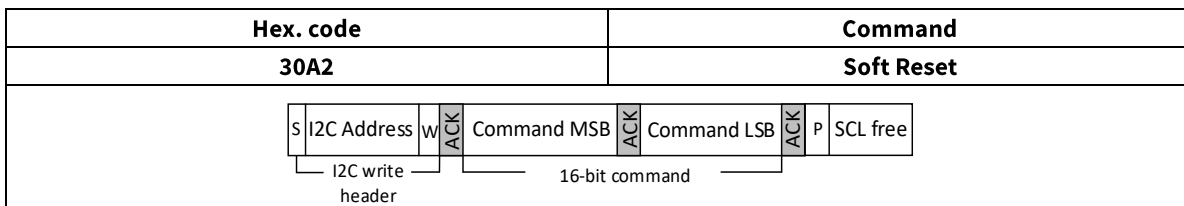

6.5.2. Reset through the nReset Pin

Pulling the nReset pin down will produce a reset, which is like a hard reset. The nReset pin is internally connected to VDD with a pull-up resistor, so the low level is effective. The nReset pin must be pulled down at least 1 μs, then the sensor can be reset.

6.5.3. Hard Reset

Turn off the power supply voltage of VDD pin, and then turn it on again to realize a hard reset. It should be noted that the voltage of pins 1 (SDA), 4 (SCL) and 2 (ADDR) should be removed to prevent the sensor from being powered by ESD diodes in order to get a hard reset.

6.6. Heater

The function of NSHT30 internal heater is only used for plausibility check. The heater will cause a temperature rise and humidity down of the sensor after being enabled. The temperature rise of the heater is related to many parameters, usually is in the range of several degrees centigrade. See [Table 6.6](#) for switching on and off commands. After a reset, the heater returns to the default condition which is disabled.

Table 6.6. Heater command (Clear blocks are controlled by the microcontroller, grey blocks by the sensor).

Hex. code		Command
MSB	LSB	
30	6D	Heater on
	66	Heater off

6.7. Status Register

6.7.1. Read Status Register

The status register mainly stores information about the operational status of the heater, the alert mode, and the execution status of the last command and the last write sequence. The status register can be read by the command shown in [Table 6.7](#). [Table 6.8](#) describes the specific contents of the status register in detail.

Table 6.7. Command to read out the status register (Clear blocks are controlled by the microcontroller, grey blocks by the sensor).

Hex. code		Command
F32D		
		Read Out of status register

Table 6.8. Description of the status register

Bit	Default value (HEX)	Default value (BIN)	Description	
Bit15	80	1	Overall alert status 0 - no active alerts 1 (default)- at least one active alert	
Bit14		0	Reserved	
Bit13		0	Heater status 0 (default)- Heater off 1 - Heater on	
Bit12		0	Reserved	
Bit11		0	RH tracking alert 0 - no alert 1 - alert	
Bit10		0	T tracking alert 0 - no alert 1 - alert	
Bit9		0	Reserved	
Bit8		0	Reserved	
Bit7		10	0	Reserved
Bit6			0	Reserved
Bit5	0		Reserved	
Bit4	1		System reset detected 0 - no reset detected 1 (default)- reset detected (hard reset, soft reset command or supply fail)	
Bit3	0		Reserved	
Bit2	0		Reserved	
Bit1	0		Command status 0 (default)- last command executed successfully 1 - last command not processed. It was either invalid or command was not received correctly	
Bit0	0		Write data checksum status 0 (default)- checksum of last write transfer was correct 1 - checksum of last write transfer failed	

6.7.2. Clear Status Register

Sending the command shown in Table 6.9 can clear all flags (Bit 15,11,10,4) in the status register to zero.

Table 6.9. Command to clear the status register (Clear blocks are controlled by the microcontroller, grey blocks by the sensor).

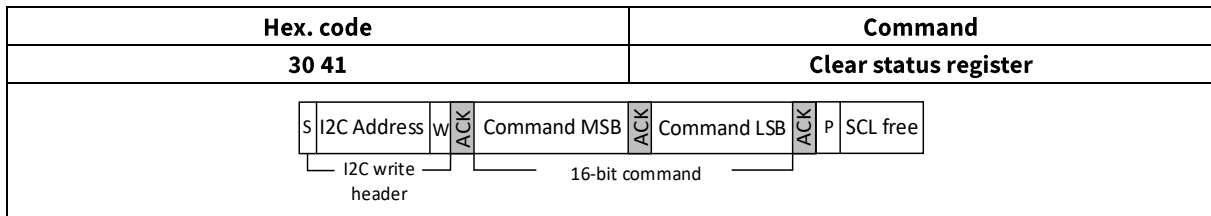

6.8. Checksum Calculation

After the temperature data and relative humidity data, the 8-bit CRC checksum bit is transmitted. It is generated by a CRC algorithm, and its calculation formula are listed in Table 6.10. The CRC is only calculated from two previously transmitted data.

Table 6.10. I²C CRC properties

Property	Value
Name	CRC-8
Width	8-bit
Protected data	read and/or write data
Polynomial	0x31 ($x^8 + x^5 + x^4 + 1$)
Initialization	0xFF
Reflect input	False
Reflect output	False
Final XOR	0x00
Examples	CRC (0xDCBA) = 0x95

6.9. Conversion of Signal Output

The output measurement data of the sensor is always a 16-bit unsigned integer. Linearization has been done and the effect of temperature and power supply voltage has been compensated. The following formulas give the calculation process of converting those raw values into a physical scale.

Conversion formula from Rawdata to relative humidity (the result is expressed in %RH):

$$RH = 100 \times \frac{S_{RH}}{2^{16} - 1}$$

Conversion formula from Rawdata to temperature (the result is expressed in °C & °F):

$$T[°C] = -45 + 175 \times \frac{S_T}{2^{16} - 1}$$

$$T[°F] = -49 + 315 \times \frac{S_T}{2^{16} - 1}$$

S_{RH} and S_T represent the sensor output Rawdata for humidity and temperature, respectively. S_{RH} and S_T used in the above formula are expressed in decimal system.

7. Activation and Deactivation of the Alert Mode

When operating in the periodic data acquisition mode, the NSHT30 has an Alert Mode. In this mode, the sensor is constantly comparing the latest acquired data from the environment to the programmable limits. The voltage of the ALERT pin will change to high level when the relative humidity or temperature data reaches the set limits. In addition, users can get the information from the status register. The ALERT pin can be used as a switch or a trigger. For example, it can turn on the LED or drive transistors to activate the climate control. In addition, the ALERT pin can be connected to the interrupt pin of the microcontroller. In this way, after the NSHT30 turns on the Alert mode, the microcontroller can wake-up from the sleep mode and then perform some operations.

7.1. Activation and Deactivation of the Alert Mode

The alert mode can be activated during the periodic data acquisition mode of the sensor. The minimum set point of the temperature and humidity limit in the alert mode should be lower than the maximum set point (LowSet < HighSet). On the contrary, if LowSet > HighSet, the alert mode will be deactivated.

7.2. Alert Mode Limits

The user can change the control limit through the corresponding command as shown in [Table 7.2](#). One advantage of NSHT30 is that it can set different temperature and humidity limits, as well as high and low limits. In addition, the setting limit is used to activate the alert, while the clearing limit is used to deactivate the alert. They can be controlled independently. This allows to remove fast oscillations of the ALERT pin close to set limit values. Different limits and the ALERT Pin status are given as shown in [Figure 7.1](#).

After the sensor is reset. The Limit values will back to the default values (as shown in [Table 7.1](#)). At the same time, all user defined limits will be lost.

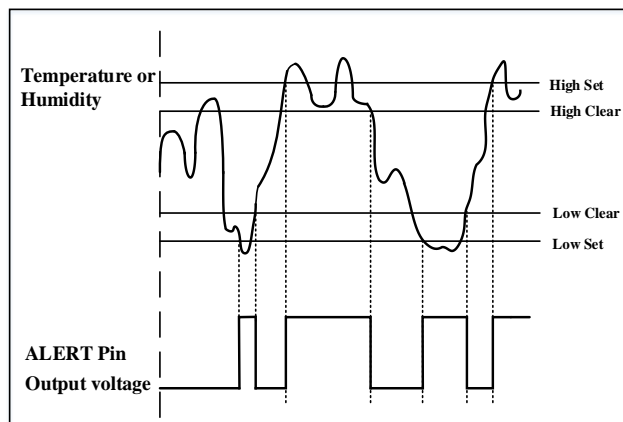

Figure 7.1 Different limits for the Alert Mode

7.2.1. Data Format for the Alert Limits

The sensor stores the limit information in a simplified data format. The standard data format width of NSHT30 acquisition data is 16-bit. So, only the most significant bit (MSB) is used to determine whether the alert setting conditions are met (where the humidity is 7 bits and the temperature is 9 bits), as shown in [Figure 7.2](#).

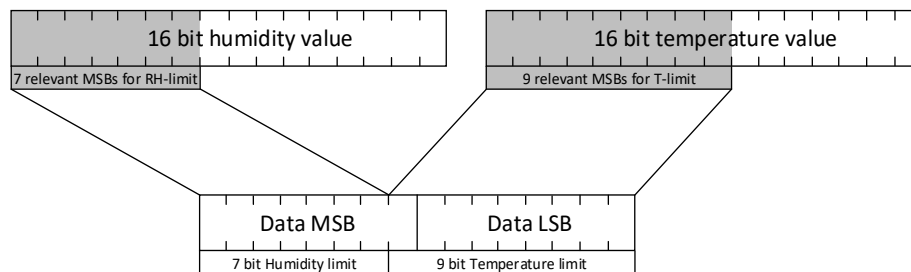

Figure 7.2 Relevant Bits for the limits

It allows the transmission of temperature and humidity limits in the same commands and dealing with them internally more effectively.

Therefore, the resolution of the limit value and the measured value are different. The resolution of the temperature limits are $\Delta T \approx 0.5^\circ\text{C}$, whereas the humidity limits can be set with a resolution of $\Delta RH \approx 1\%$. Pay attention that the data is always in a complete 16-bit format during measurement and storage. The simplified data format is only used to judge whether the alert conditions are met.

7.2.2. Default Values for the Alert Limits

Default limits are loaded into registers during power up or reset. These limits can be changed by sending instructions as shown in [Table 7.2](#).

Table 7.1 Default values for the Alert limits. The limits can be changed with the command shown in Table 7.2

Default Value		Alert Limit	
Hex Code	Physical Value (RH/T)		
CD 33	79.7%RH / 60°C	set limit	High alert limit
C9 2D	78.2% RH / 58°C	clear limit	
34 66	20.3% RH / -10°C	set limit	Low alert limit
38 69	21.8% RH / -9°C	clear limit	

7.2.3. Alert Mode Commands

The commands for reading eight different limits are listed in [Table 7.2](#). Each command is sent by the master, and the temperature and relative humidity limits can be read from the sensor.

Table 7.2 Alert limit commands for reading the alert limits.

Hex. code		Command		
Command	Command LSB			
E1	1F	READ	High alert limit	set
	14			clear
	02		Low alert limit	set
	09			clear
61	1D	WRITE	High alert limit	set
	16			clear
	00		Low alert limit	set
	0B			clear

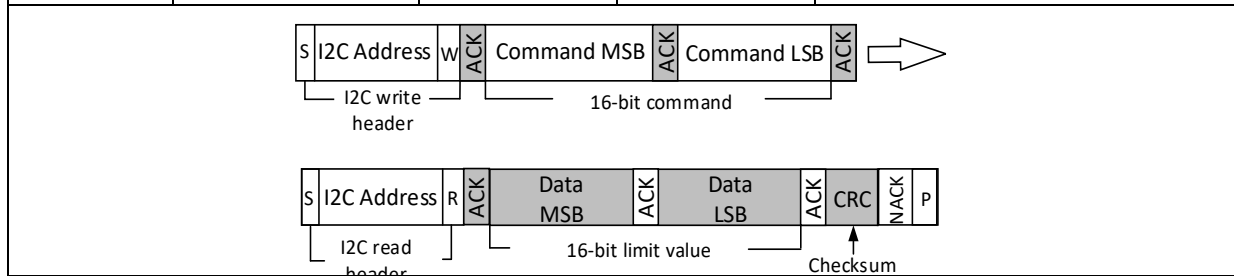
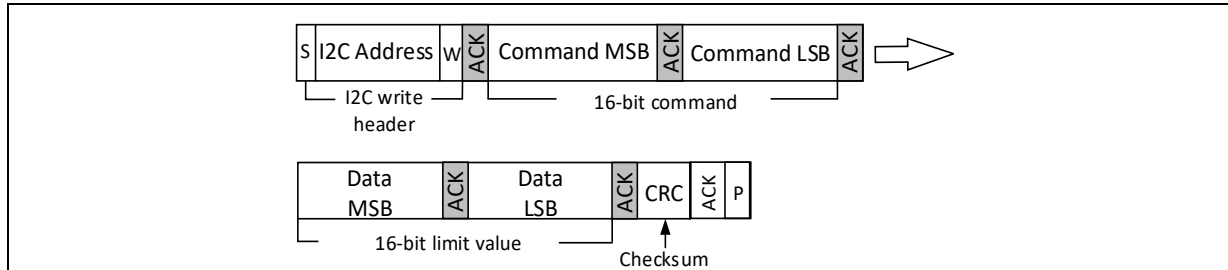

Table 7.3 Alert limit commands for writing the alert limits.**7.2.4. Typical Procedure to Calculate the Limits**

As shown in [Figure 7.2](#), the reduced data format is given.

1. Choose the limits for RH and T (e.g. High alert clear limit, $RH_{Highclear}=78.2\%$ RH & $T_{Highclear}=58^{\circ}C$)
2. Convert the $RH_{Highclear}$ and the $T_{Highclear}$ limits to their respective 16-bit binary value
 - a. $RH_{Highclear}=1100'1000'0011'0000$
 - b. $T_{Highclear}=1001'0110'1010'1100$
3. Remove the 9 LSBs of the $RH_{Highclear}$ limits
 - a. $RH_{Highclear}=1100'1000'0011'0000$
4. Remove the 7 LSBs of the $T_{Highclear}$ limits
 - a. $T_{Highclear}=1001'0110'1010'1100$
5. Combine the reduced values (step 3 and 4) according to [Figure 7.2](#)
 - a. $RH,T_{Highclear}=1100'1001'0010'1101=0x\ C92D$
6. Calculate the 8-bit CRC from the 16-bit limit value
 - a. $CRC=CRC(0x\ C9,0x\ 2D)=0x\ 22$

7.2.5. Typical Procedure to Change the Alert Condition

1. Calculate the limits as explained in [Section 7.2.4](#) (the default values are the normal range and shown in [Table 7.1](#))
2. Write the limit to the sensor as described in [Table 7.2](#) & [Table 7.3](#).
3. Read out the limit as described in [Table 7.2](#) & [Table 7.3](#) to verify the Write process.
4. Set the sensor into periodic mode with the appropriate command.

The alert mode is now active.

7.3. Further Condition that Can Raise an Alert

Power on or reset can make the ALERT pin active (high level) no matter whether the user cuts off the power, sends reset command (soft reset) or resets through the nRESET pin. As shown in [Table 6.9](#), the contents of the status register are described.

8. Application Note

8.1. Typical Application Circuit

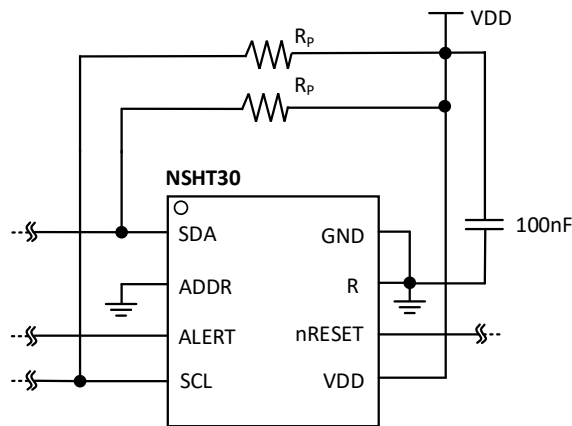

Figure 8.1 Typical application circuit for NSHT30

For more descriptions, please refer to the document of Application Note.

8.2. Soldering Reflow

NSHT30 can be soldered using a standard reflow soldering furnace. It can withstand the welding process, including the curve in accordance with IPC/JEDEC J-STD-020, with a peak temperature of 260 °C. After reflow process, the humidity sensors may temporarily get a negative humidity offset. This is because when a relative humidity sensor is exposed to the high temperature in the soldering process, the sensor element tends to dry out. The offset will slowly disappear by itself when the sensor is exposed to ambient conditions.

If RH testing is performed immediately after reflow soldering, this offset should be considered when defining the test limits. To avoid the offset in the relative humidity readings, the sensor element must be rehydrated after the soldering process. The recommended rehydration conditions are either:

- A relative humidity > 75% RH at room temperature for at least 12 hours
- A relative humidity of 40% ~ 50% RH at room temperature for 3 to 5 days

9. Package Information

9.1. DFN (8) Package

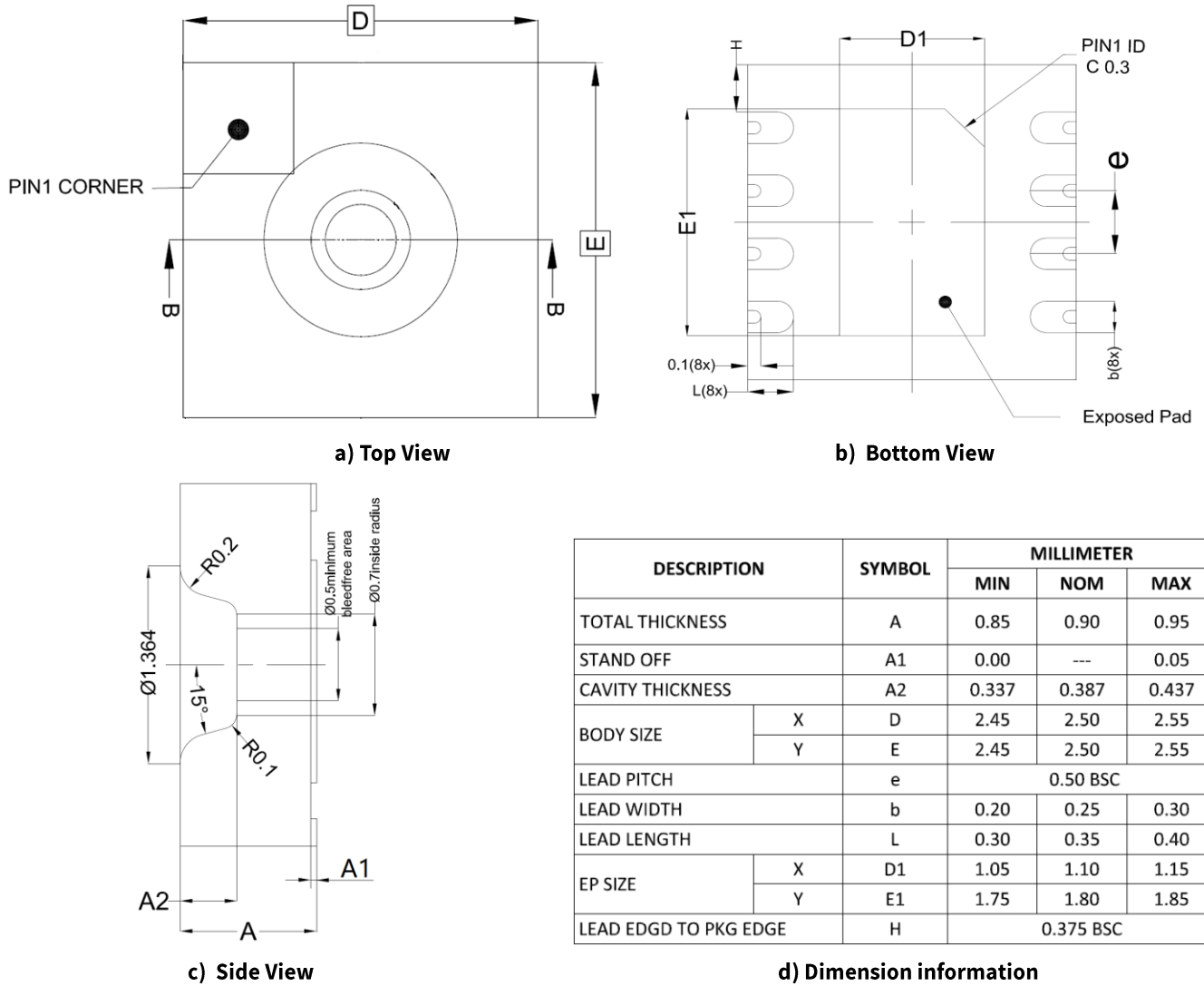

Figure 9.1. DFN (8) Package Shape and Dimension in millimeters

10. Order Information

Orderable Device	Package Qty	MSL	Device Marking	Description
NSHT30-QDNR	3000ea/Reel	1	NSHT30 YYWWZXX	DFN8 Package, Tape Reel

NOTE: All packages are RoHS-compliant with peak reflow temperatures of 260°C according to the JEDEC industry standard classifications and peak solder temperatures(Reflow profile:J-STD-020E).

11. Marking

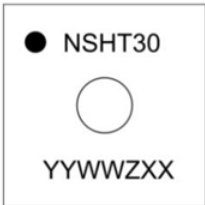
Device	Package	Marking Information	Description
NSHT30-QDNR	DFN8	Line1:NSHT30 Line 2:YYWWZXX	<div style="border: 1px solid black; padding: 5px; width: fit-content; margin: 0 auto;">  </div> <p>NSHT30: product type NSHT30</p> <p>YY: year WW: week ZXX: lot tracking ID</p>

12. Tape and Reel Information

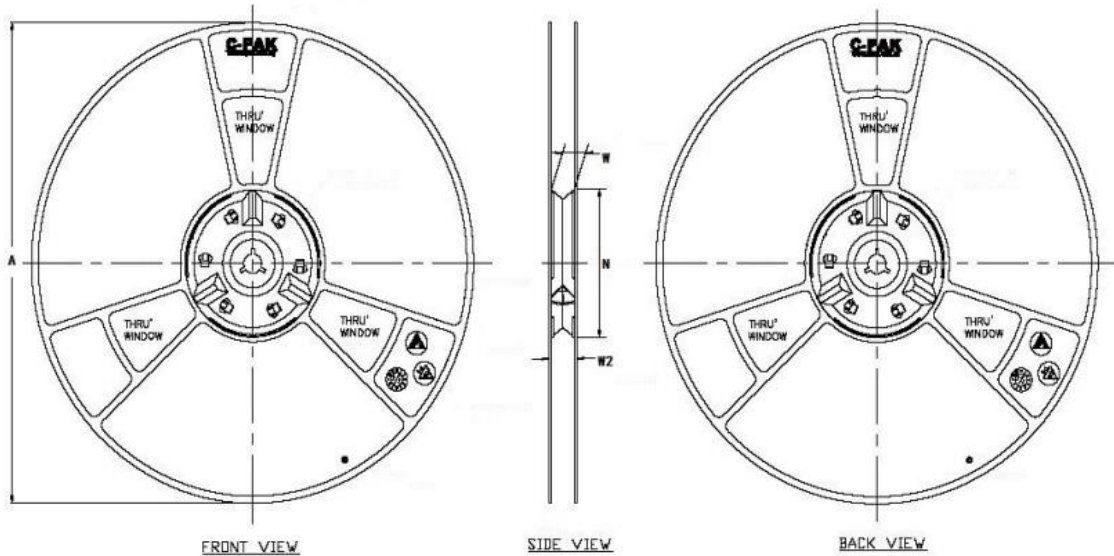

Item	Parameters	Method	Min.	Max.
1	ΦA (Max 330 mm)	Caliper	328.75	329.05
2	ΦN (Min 100mm)	Caliper	100.75	101.06
3	W1 (12.4 +2/-0mm)	Caliper	13.42	13.56
4	W2 (Max 18.4 mm)	Caliper	17.43	17.69

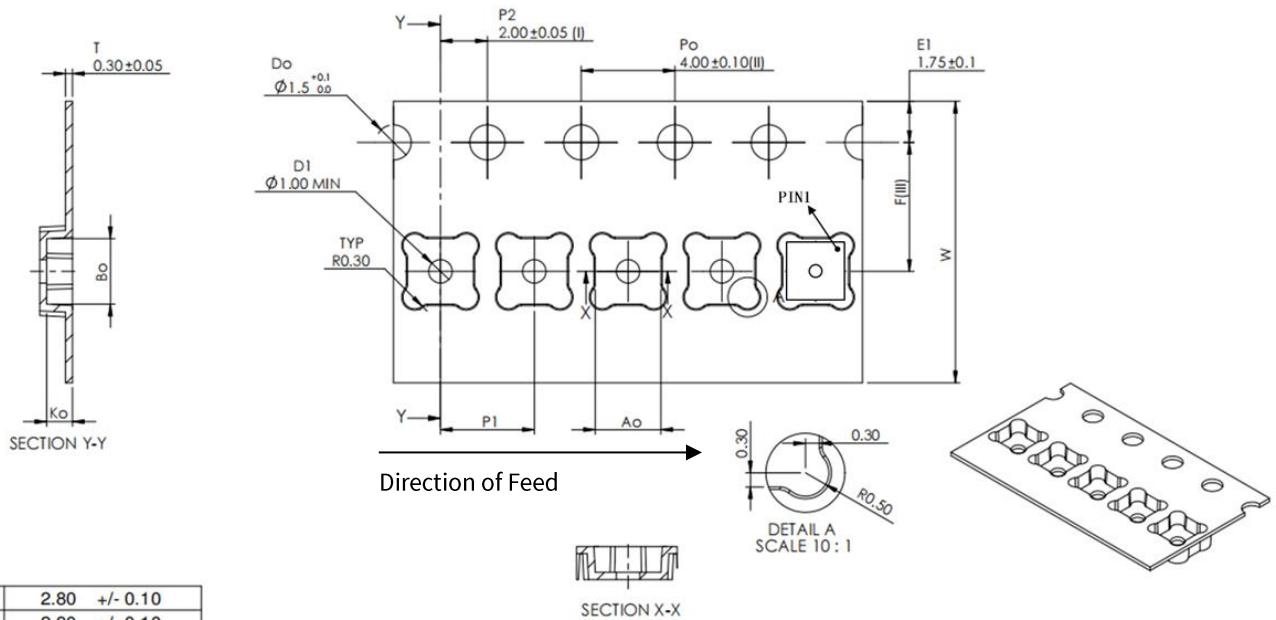

Ao	2.80 +/- 0.10
Bo	2.80 +/- 0.10
Ko	1.10 +/- 0.10
F	5.50 +/- 0.05
P1	4.00 +/- 0.10
W	12.00 +/- 0.30

ALL DIMENSIONS IN MILLIMETERS UNLESS OTHERWISE STATED

Figure 12.1. Tape and Reel Information

Header tape is to the right and trailer tape to the left on this drawing.

13. Revision History

Revision	Description	Date
0.1	Initial Version.	2021/2/8
0.2	Update ESD test results.	2021/7/28
0.3	Modify description and figures; Modify electrical characteristics parameters	2022/9/27
1.0	Update some electrical characteristics parameters and Order Information	2023/8/5

IMPORTANT NOTICE

The information given in this document (the “Document”) shall in no event be regarded as any warranty or authorization of, express or implied, including but not limited to accuracy, completeness, merchantability, fitness for a particular purpose or infringement of any third party’s intellectual property rights.

Users of this Document shall be solely responsible for the use of NOVOSENSE’s products and applications, and for the safety thereof. Users shall comply with all laws, regulations and requirements related to NOVOSENSE’s products and applications, although information or support related to any application may still be provided by NOVOSENSE.

This Document is provided on an “AS IS” basis, and is intended only for skilled developers designing with NOVOSENSE’ products. NOVOSENSE reserves the rights to make corrections, modifications, enhancements, improvements or other changes to the products and services provided without notice. NOVOSENSE authorizes users to use this Document exclusively for the development of relevant applications or systems designed to integrate NOVOSENSE’s products. No license to any intellectual property rights of NOVOSENSE is granted by implication or otherwise. Using this Document for any other purpose, or any unauthorized reproduction or display of this Document is strictly prohibited. In no event shall NOVOSENSE be liable for any claims, damages, costs, losses or liabilities arising out of or in connection with this Document or the use of this Document.

For further information on applications, products and technologies, please contact NOVOSENSE (www.novosns.com).

Suzhou NOVOSENSE Microelectronics Co., Ltd