



2SD718

NPN EPITAXIAL SILICON TRANSISTOR

HIGH POWER AMPLIFIER APPLICATION

■ **FEATURES**

- * Recommended for 45~50W Audio Frequency Amplifier Output Stage.
- * Complementary to 2SB688.

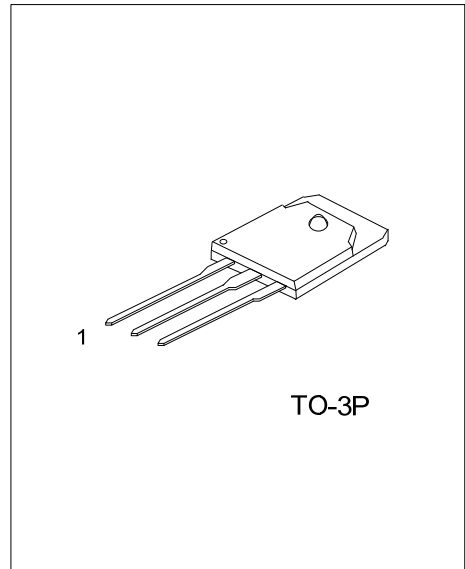

■ **ORDERING INFORMATION**

Ordering Number		Package	Pin Assignment			Packing
Lead Free	Halogen Free		1	2	3	
2SD718L-x-T3P-T	2SD718G-x-T3P-T	TO-3P	B	C	E	Tube

Note: Pin Assignment: B: Base C: Collector E: Emitter

<p>2SD718G-x-T3P-T</p>	<p>(1) T: Tube (2) T3P: TO-3P (3) x: refer to Classification of h_{FE} (4) G: Halogen Free and Lead Free, L: Lead Free</p>
------------------------	--

■ **MARKING**

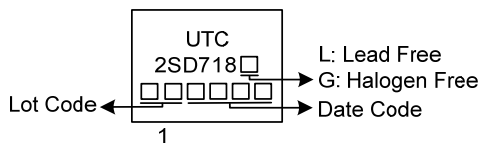

■ ABSOLUTE MAXIMUM RATING ($T_A=25^\circ\text{C}$, unless otherwise specified)

PARAMETER	SYMBOL	RATINGS	UNIT
Collector-Base Voltage	V_{CBO}	120	V
Collector-Emitter Voltage	V_{CEO}	120	V
Emitter-Base Voltage	V_{EBO}	5	V
Collector Current	I_C	10	A
Base Current	I_B	1	A
Collector Power Dissipation ($T_c=25^\circ\text{C}$)	P_C	80	W
Junction Temperature	T_J	+150	$^\circ\text{C}$
Storage Temperature Range	T_{STG}	-55 ~ +150	$^\circ\text{C}$

Note: Absolute maximum ratings are those values beyond which the device could be permanently damaged. Absolute maximum ratings are stress ratings only and functional device operation is not implied.

■ ELECTRICAL CHARACTERISTICS ($T_A=25^\circ\text{C}$, unless otherwise specified)

PARAMETER	SYMBOL	TEST CONDITIONS	MIN	TYP	MAX	UNIT
Collector-Emitter Breakdown Voltage	$V_{(BR)CEO}$	$I_C=50\text{mA}$, $I_B=0$	120			V
Collector Cut-off Current	I_{CBO}	$V_{CB}=120\text{V}$, $I_E=0$			10	μA
Emitter Cut-off Current	I_{EBO}	$V_{EB}=5\text{V}$, $I_C=0$			10	μA
DC Current Gain	h_{FE}	$V_{CE}=5\text{V}$, $I_C=1\text{A}$	55		160	
Collector-Emitter Saturation Voltage	$V_{CE(sat)}$	$I_C=6\text{A}$, $I_B=0.6\text{A}$			2.0	V
Base-Emitter Voltage	V_{BE}	$V_{CE}=5\text{V}$, $I_C=5\text{A}$			1.5	V
Transition Frequency	f_T	$V_{CE}=5\text{V}$, $I_C=1\text{A}$		12		MHz
Collector Output Capacitance	C_{ob}	$V_{CB}=10\text{V}$, $I_E=0$, $f=1\text{MHz}$		170		pF

■ CLASSIFICATION OF h_{FE}

RANK	R	O
RANGE	55 ~ 110	80 ~ 160

TYPICAL CHARACTERISTICS

