

mm inch

FEATURES

- 40 A rating at 85°C 185°F
- ISO type terminals
- High shock resistance for drop test requirements (2 meters 6.6 feet)
- Low temperature rise — all current carrying material is copper.
- Plug-in and PC board type

SPECIFICATIONS

Contact

(1) Standard type (12V coil voltage)

Arrangement		1 Form A	1 Form C	High contact capacity (1 Form A)
Rating	Nominal switching capacity	40 A 14 V DC	N.O.: 40 A 14 V DC N.C.: 30 A 14 V DC	70 A 14 V DC (at 20°C 68°F) 50 A 14 V DC (at 85°C 185°F)
	Max. carry current (Initial) (at 85°C 185°F)	N.O.: 40 A 14 V DC	N.O.: 40 A 14 V DC N.C.: 30 A 14 V DC	N.O.: 40 A 14 V DC
Initial contact resistance (By voltage drop 6 V DC 1 A)		Max. 15mΩ		
Contact material		Silver alloy		
Min. switching capacity#1		1 A 12 V DC (12 V DC), 1 A 24 V DC (24 V DC),		
Expected life	Mechanical (at 120 cpm)	Min. 10 ⁶		
	Electrical (at rated load)	Flux-resistant type: Min. 10 ⁵ *1 Sealed type: Min. 5 × 10 ⁴		

#1 This value can change due to the switching frequency, environmental conditions, and desired reliability level, therefore it is recommended to check this with the actual load.

(2) Standard type (24V coil voltage)

Arrangement		1 Form A	1 Form C	High contact capacity (1 Form A)
Rating	Nominal switching capacity	20 A 28V DC	N.O.: 20 A 28 V DC N.C.: 10 A 28 V DC	20 A 28V DC
	Max. carry current (Initial) (at 85°C 185°F)	20 A 28 V DC	N.O.: 20 A 28 V DC N.C.: 10 A 28 V DC	20 A 28 V DC

*1 All other specifications are the same as those of standard type (12V coil voltage)

(3) Heat resistant type (12V, 24V coil voltage)

Type		12V coil voltage			24V coil voltage		
Arrangement		1 Form A	1 Form C	High contact capacity (1 Form A)	1 Form A	1 Form C	High contact capacity (1 Form A)
Rating	Nominal switching capacity	40 A 14V DC	N.O.: 40 A 14 V DC N.C.: 30 A 14 V DC	40 A 14V DC	20 A 28 V DC	N.O.: 20 A 28 V DC N.C.: 10 A 28 V DC	20 A 28 V DC
	Max. carry current (Initial) (at 85°C 185°F)*	50 A 14 V DC	N.O.: 50 A 14 V DC N.C.: 30 A 14 V DC	45 A 14 V DC 50 A 14 V DC*2	25 A 28V DC	N.O.: 25 A 28 V DC N.C.: 10 A 28 V DC	25 A 28V DC

*1 All other specifications are the same as those of standard type (12V coil voltage)

*2 PC board type

* Current value in which carry current is possible when the coil temperature is 180°C 356°F.

Coil

Arrangement	Coil voltage	Nominal operating power
1 Form A, 1 Form C	12V DC	1.4W
	24V DC	1.8W
High contact capacity (1 Form A)	12V DC	1.8W (1.4W: PC board type)
	24V DC	1.8W (1.4W: PC board type)

Characteristics

Max. operating speed (at rated load)	15 cpm	
Initial insulation resistance*2	Min. 20 MΩ (at 500 V DC)	
Initial breakdown voltage*3	Between open contacts	500 Vrms for 1 min.
	Between contacts and coil	500 Vrms for 1 min.
Operate time*4 (at nominal voltage)	Max. 15 ms (Initial)	
Release time (without diode)*4 (at nominal voltage)	Max. 15 ms (Initial)	
Shock resistance	Functional	Min. 200 m/s ² {20 G}
	Destructive	Min. 1,000 m/s ² {100 G}
Vibration resistance	Functional	10 Hz to 500 Hz, Min. 44.1m/s ² {4.5G}
	Functional*5	10 Hz to 2,000 Hz, Min. 44.1m/s ² {4.5G}
Conditions for operation, transport and storage*6 (Not freezing and condensing at low temperature)	Ambient temp.	-40°C to +85°C -40°F to +185°F (Heat resistant type: -40°C to +125°C -40°F to +257°F)
	Humidity	5% R.H. to 85% R.H.
Mass	Approx. 33 g 1.16 oz	

Remarks

- *1 At nominal switching capacity, operating frequency: 2s ON, 2s OFF
- *2 Measurement at same location as "Initial breakdown voltage" section
- *3 Detection current: 10 mA
- *4 Excluding contact bounce time

*5 Time of vibration for each direction; X, Y, Z direction: 4 hours



*6 Refer to 6. Conditions for operation, transport and storage mentioned in [AMBIENT ENVIRONMENT](#) (p. 19, [Relay Technical Information](#)).

TYPICAL APPLICATIONS

- Head lights
- ABS
- Air conditioner
- Starters
- Head Lamp
- Tractor, Combine

ORDERING INFORMATION

CB						
1		F		T	M	12 V
Contact arrangement	Protective construction	Heat resistant of types	Mounting classification	Coil voltage (DC)		
1a: 1 Form A 1: 1 Form C 1aH: High contact capacity (1 Form A)	Nil: Sealed type F: Flux-resistant type	Nil: Standard type T: Heat resistant type D: Diode R: Resistor	Nil: Plug-in type P: PC board type M: Bracket type	12, 24 V		

Note: Bulk package: 50 pcs.; Case: 200 pcs.

TYPES

1. Standard type

Contact arrangement	Mounting classification	Coil voltage, V DC	Part No.	
			Sealed type	Flux-resistant type
1 Form A	PC board type	12V	CB1aP-12V	CB1aF-P-12V
		24V	CB1aP-24V	CB1aF-P-24V
	Plug-in type	12V	CB1a-12V	CB1aF-12V
		24V	CB1a-24V	CB1aF-24V
	Bracket type	12V	CB1aM-12V	CB1aF-M-12V
		24V	CB1aM-24V	CB1aF-M-24V
1 Form C	PC board type	12V	CB1P-12V	CB1F-P-12V
		24V	CB1P-24V	CB1F-P-24V
	Plug-in type	12V	CB1-12V	CB1F-12V
		24V	CB1-24V	CB1F-24V
	Bracket type	12V	CB1M-12V	CB1F-M-12V
		24V	CB1M-24V	CB1F-M-24V
High contact capacity (1 Form A)	PC board type*	12V	CB1aHP-12V	CB1aHF-P-12V
		24V	CB1aHP-24V	CB1aHF-P-24V
	Plug-in type	12V	CB1aH-12V	CB1aHF-12V
		24V	CB1aH-24V	CB1aHF-24V
	Bracket type	12V	CB1aHM-12V	CB1aHF-M-12V
		24V	CB1aHM-24V	CB1aHF-M-24V

* Regarding solder, this product is not MIL (Military Standard) compliant. Please evaluate solder mounting by the actual equipment before using.

2. Heat resistant type

Contact arrangement	Mounting classification	Coil voltage, V DC	Part No.	
			Sealed type	Flux-resistant type
1 Form A	PC board type	12V	CB1a-T-P-12V	CB1aF-T-P-12V
		24V	CB1a-T-P-24V	CB1aF-T-P-24V
	Plug-in type	12V	CB1a-T-12V	CB1aF-T-12V
		24V	CB1a-T-24V	CB1aF-T-24V
	Bracket type	12V	CB1a-T-M-12V	CB1aF-T-M-12V
		24V	CB1a-T-M-24V	CB1aF-T-M-24V
1 Form C	PC board type	12V	CB1-T-P-12V	CB1F-T-P-12V
		24V	CB1-T-P-24V	CB1F-T-P-24V
	Plug-in type	12V	CB1-T-12V	CB1F-T-12V
		24V	CB1-T-24V	CB1F-T-24V
	Bracket type	12V	CB1-T-M-12V	CB1F-T-M-12V
		24V	CB1-T-M-24V	CB1F-T-M-24V
High contact capacity (1 Form A)	PC board type*	12V	CB1aH-T-P-12V	CB1aHF-T-P-12V
		24V	CB1aH-T-P-24V	CB1aHF-T-P-24V
	Plug-in type	12V	CB1aH-T-12V	CB1aHF-T-12V
		24V	CB1aH-T-24V	CB1aHF-T-24V
	Bracket type	12V	CB1aH-T-M-12V	CB1aHF-T-M-12V
		24V	CB1aH-T-M-24V	CB1aHF-T-M-24V

* Regarding solder, this product is not MIL (Military Standard) compliant. Please evaluate solder mounting by the actual equipment before using.

COIL DATA (at 20°C 68°F)

Contact arrangement	Nominal voltage, V DC	Pick-up voltage, V DC*	Drop-out voltage, V DC	Nominal current, mA	Coil resistance, Ω	Nominal operating power, W	Usable voltage range, V DC
1 Form A	12	Max. 3 to 7	Min. 1.2 to 4.2	117±10%	103±10%	1.4	10 to 16
1 Form C	24	Max. 6 to 14	Min. 2.4 to 8.4	75±10%	320±10%	1.8	20 to 32
High contact capacity (1 Form A)	12	Max. 3 to 7	Min. 1.2 to 4.2	117±10%	103±10%	1.4 (PC board type)	10 to 16
				150±10%	80±10%	1.8	
	24	Max. 6 to 14	Min. 2.4 to 8.4	58±10%	411±10%	1.4 (PC board type)	20 to 32
				75±10%	320±10%	1.8	

* Other pick-up voltage types are also available. Please contact us for details.

DIMENSIONS

mm inch

1. PC board type

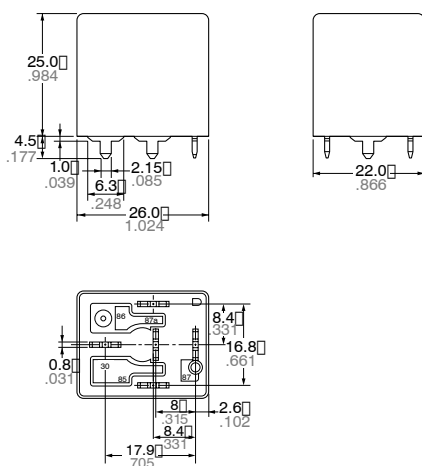

Schematic (Bottom view)

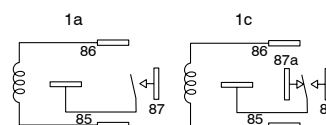

PC board pattern

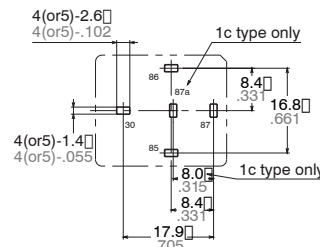

Dimension:	General tolerance
Max. 1mm .039 inch:	±0.1 ±.004
1 to 3mm .039 to .118 inch:	±0.2 ±.008
Min. 3mm .118 inch:	±0.3 ±.012

2. Plug-in type

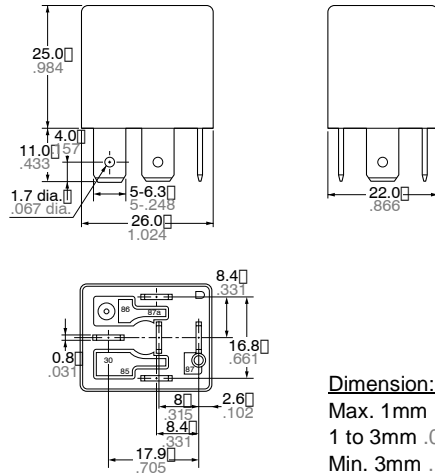

Dimension:
 Max. 1mm .039 inch:
 1 to 3mm .039 to .118 inch:
 Min. 3mm .118 inch:

General tolerance
 $\pm 0.1 \pm .004$
 $\pm 0.2 \pm .008$
 $\pm 0.3 \pm .012$

Schematic (Bottom view)

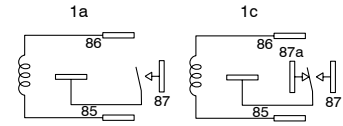

3. Bracket type

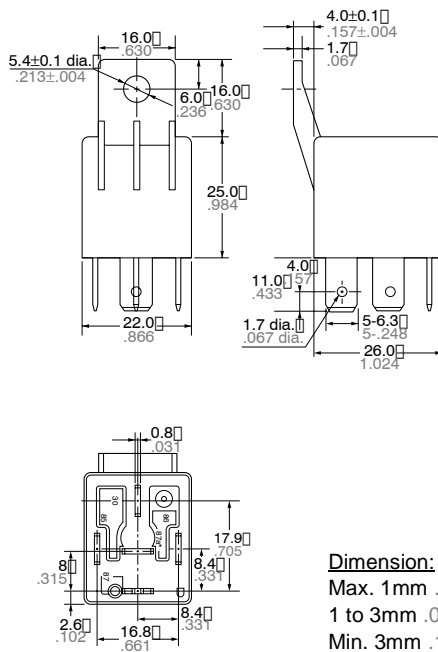

Dimension:
 Max. 1mm .039 inch:
 1 to 3mm .039 to .118 inch:
 Min. 3mm .118 inch:

General tolerance
 $\pm 0.1 \pm .004$
 $\pm 0.2 \pm .008$
 $\pm 0.3 \pm .012$

mm inch

Schematic (Bottom view)

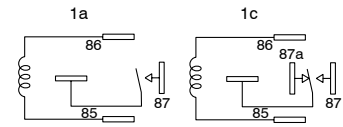

4. High contact capacity type (Plug-in terminal type)

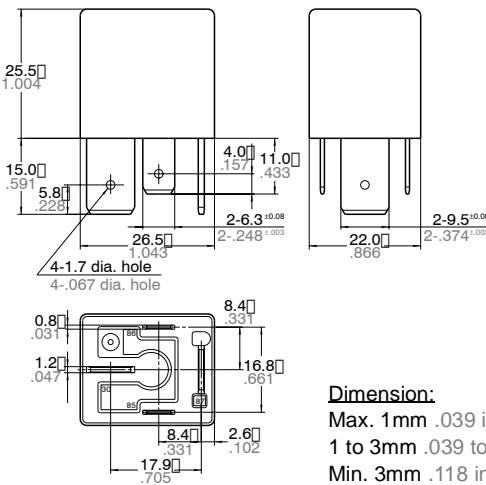

Dimension:
 Max. 1mm .039 inch:
 1 to 3mm .039 to .118 inch:
 Min. 3mm .118 inch:

General tolerance
 $\pm 0.1 \pm .004$
 $\pm 0.2 \pm .008$
 $\pm 0.3 \pm .012$

Schematic (Bottom view)

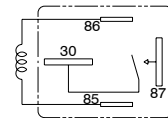

High contact capacity type (PC board terminal type)

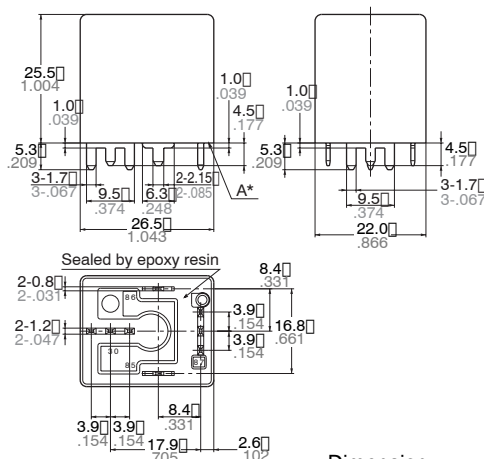

Schematic (Bottom view)

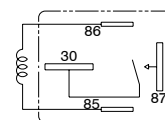

PC board pattern

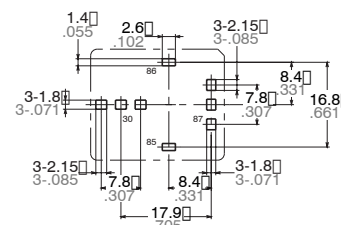

Dimension:	General tolerance
Max. 1mm .039 inch:	±0.1 ±.004
1 to 3mm .039 to .118 inch:	±0.2 ±.008
Min. 3mm .118 inch:	±0.3 ±.012

* Intervals between terminals is measured at A surface level.

REFERENCE DATA

CB RELAYS Standard type (Heat resistant type)

1. Ambient temperature and current value in which carry current is possible

*Precondition: Initial

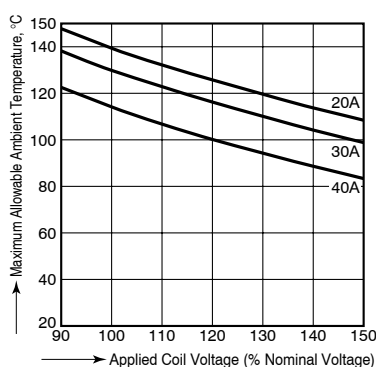

Assumption:

- Maximum mean coil temperature = 180°C
- Curves are based on 1.4W (Nominal power consumption of the unsuppressed coil at nominal voltage)

2. Max. switching capability (Resistive load) (Standard type)

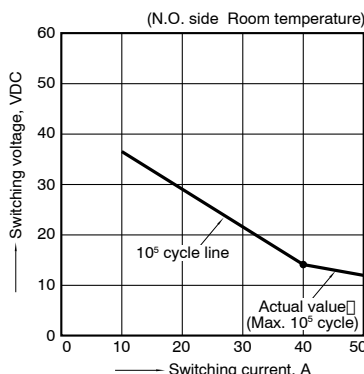

3. Ambient temperature and operating temperature range (Standard type)

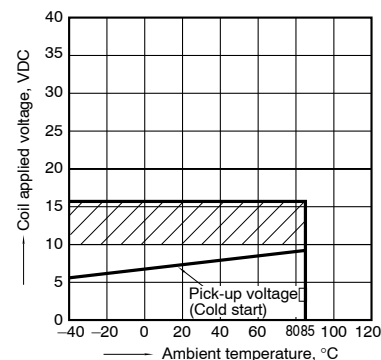

4. Distribution of pick-up and drop-out voltage
Sample: CB1-P-12V, 42pcs.

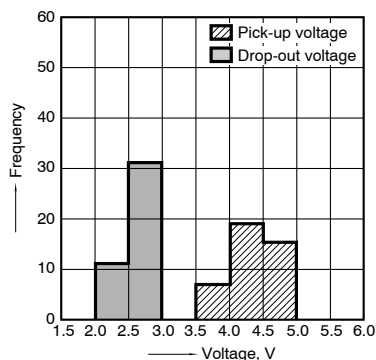

5. Distribution of operate and release time
Sample: CB1-P-24V, 42pcs.
* Without diode

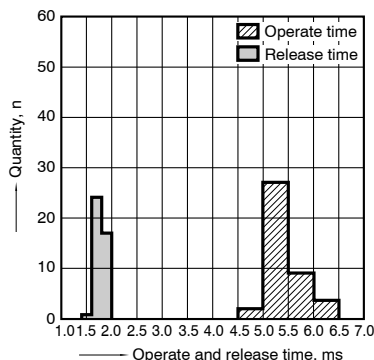

6-(1). Electrical life test (Motor free)

Sample: CB1F-12V, 5pcs.
 Load: 25A 14V DC, motor free actual load
 Switching frequency: (ON:OFF = 1s:9s)
 Ambient temperature: Room temperature
 Circuit

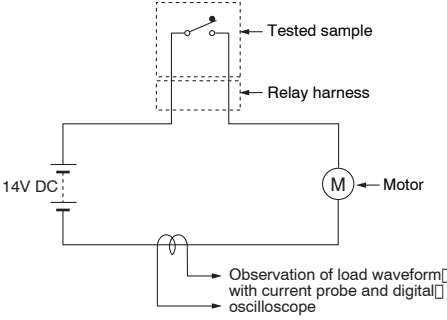

Load current waveform

Inrush current: 80A, Steady current: 25A,

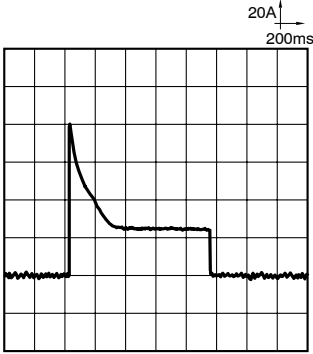

Change of pick-up and drop-out voltage

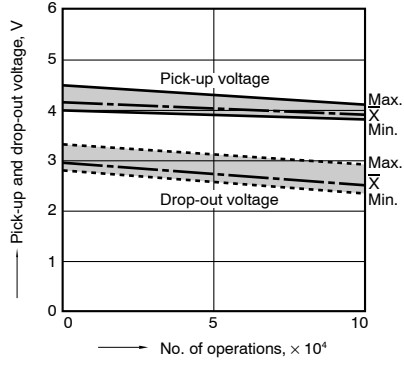

Change of contact resistance

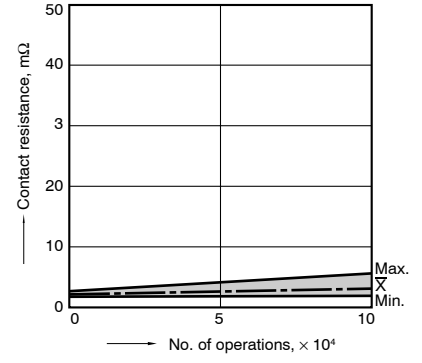

6-(2). Electrical life test (Lamp load)

Sample: CB1F-12V, 5pcs.
 Load: 45/65Wx5 parallel, 14V DC, halogen lamp actual load
 Switching frequency: (ON:OFF = 1s:8s)
 Ambient temperature: Room temperature
 Circuit

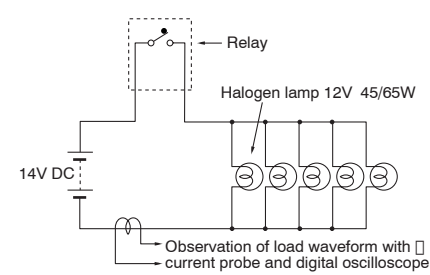

Load current waveform

Inrush current: 100A, Steady current: 20A,

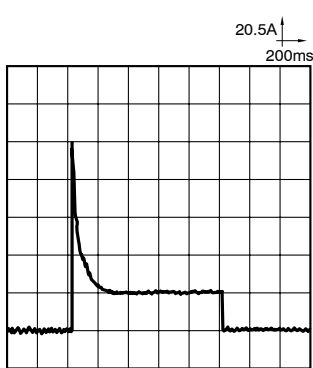

Change of pick-up and drop-out voltage

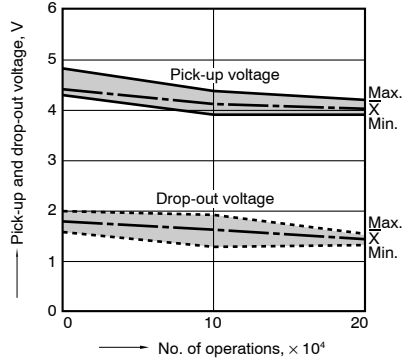

Change of contact resistance

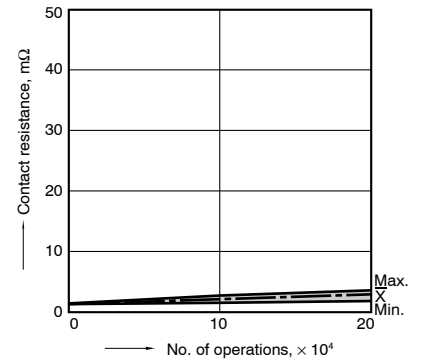

CB RELAYS High capacity type (Heat resistant type)

1. Ambient temperature and current value in which carry current is possible

*Precondition: Initial

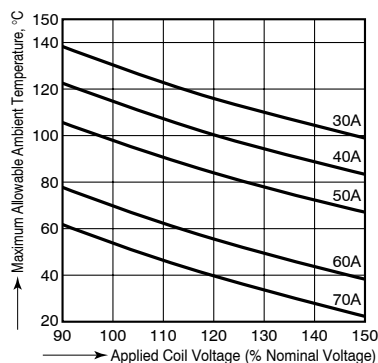

Assumption:

- Maximum mean coil temperature = 180°C
- Curves are based on 1.4W (Nominal power consumption of the unsuppressed coil at nominal voltage)

2. Max. switching capability (High capacity type)

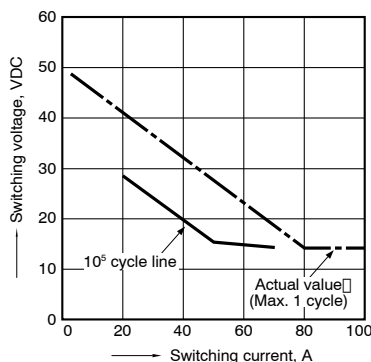

3. Ambient temperature and operating temperature range (Heat resistant type)

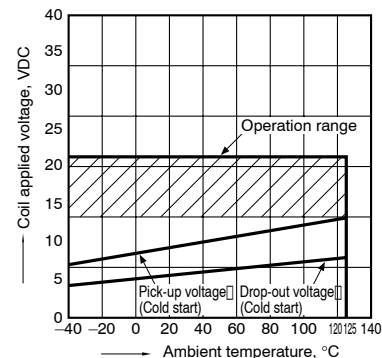

4. Distribution of pick-up and drop-out voltage

Sample: CB1aHF-12V, 53pcs.

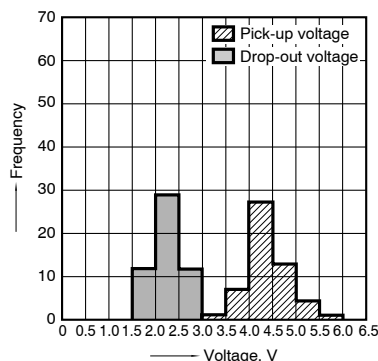

5. Distribution of operate and release time

Sample: CB1aHF-12V, 53pcs.

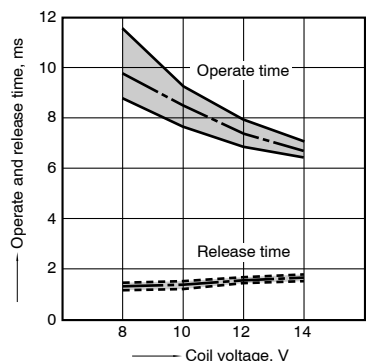

6. Contact resistance

Sample: CB1aHF-12V, 53pcs. (By voltage drop 6V DC 1A)

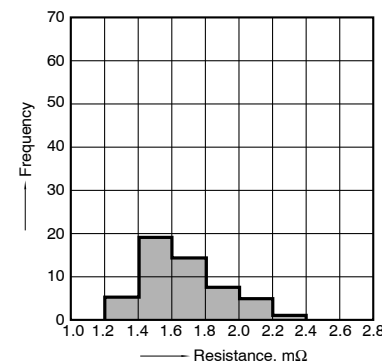

6-(1). Electrical life test (Motor free)

Sample: CB1aH-12V, 3pcs.
 Load: Inrush current: 64A/Steady current: 35A
 Fan motor actual load (motor free) 12V DC
 Switching frequency: (ON:OFF = 3s:7s)
 Ambient temperature: Room temperature
 Circuit

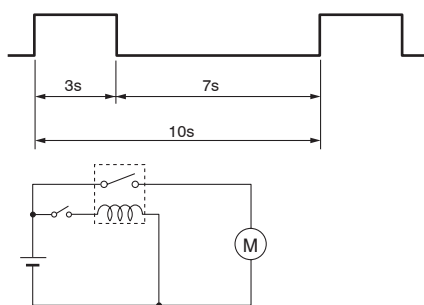

Load current waveform

Inrush current: 64A, Steady current: 35A,

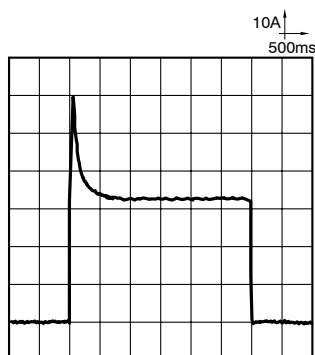

Change of pick-up and drop-out voltage

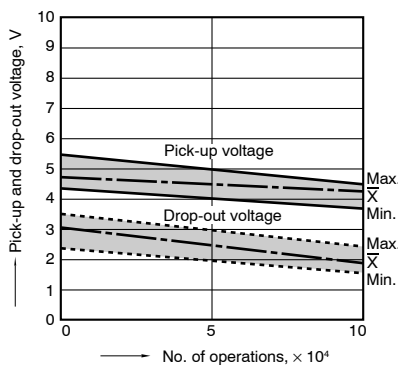

Change of contact resistance

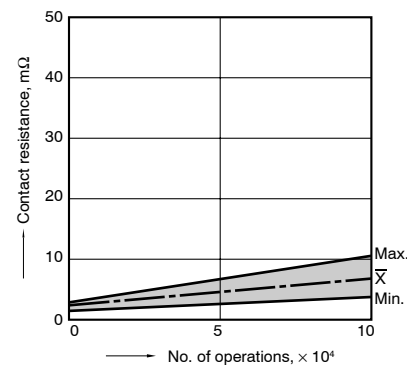

6-(2). Electrical life test (Motor lock)

Sample: CB1aH-12V, 5pcs.
 Load: 100A 14V DC
 Magnet clutch actual load (lock condition)
 Switching frequency: (ON:OFF = 1s:9s)
 Ambient temperature: Room temperature
 Circuit

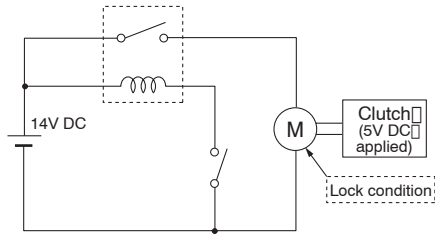

Change of pick-up and drop-out voltage

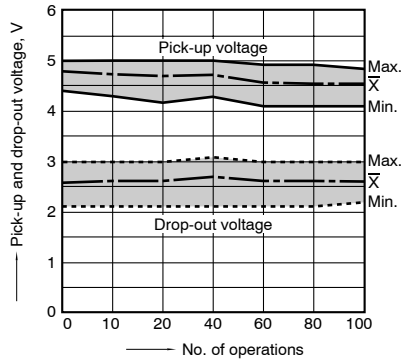

Change of contact resistance

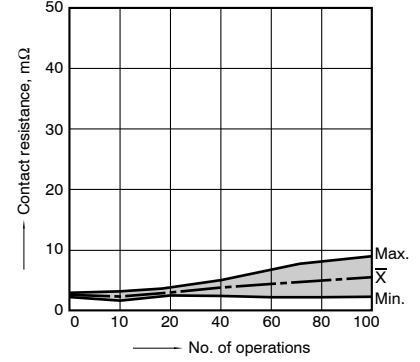

Load current waveform

100A 14V DC

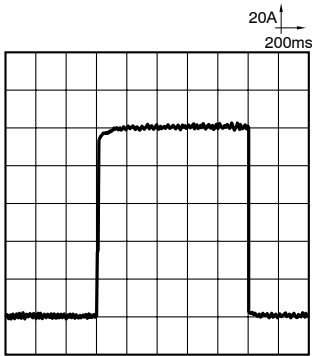

Cautions regarding the protection element

1. Part numbers without protection elements

1) 12 V models

When connecting a coil surge protection circuit to these relays, we recommend a Zener diode with a Zener voltage of 24 V or higher, or a resistor (680Ω to 1,000Ω). When a diode is connected to the coil in parallel, the release time will slow down and working life may shorten. Before use, please check the circuit and verify that the diode is not connected in parallel to the coil drive circuit.

2) 24 V models

When connecting a coil surge protection circuit to these relays, we recommend a Zener diode with a Zener voltage of 48 V or higher, or a resistor (2,800Ω to 4,700Ω).

When a diode is connected to the coil in parallel, the release time will slow down and working life may shorten. Before use, please check the circuit and verify that the diode is not connected in parallel to the coil drive circuit.

2. Part numbers with diodes

These relays use a diode in the coil surge protection element. Therefore, the release time is slower and the working life might be shorter compared to part numbers without protection elements and part numbers with resistors. Be sure to use only after evaluating under actual load conditions.

3. Part numbers with resistors

This part number employs a resistor in the coil surge protection circuit; therefore, an external surge protection element is not required. In particular, when a diode is connected in parallel with a coil, the revert time becomes slower which could adversely affect working life. Please check the circuit and make sure that a diode is not connected in parallel with the coil drive circuit.

For Cautions for Use, see [Relay Technical Information](#).