

SPECIFICATION

REFOND P/N

RF-BNRI35TS-DF-N

R&D

Mass Product



Contents

1. Description	3
1.1 General Description.....	3
1.2 Features	3
1.3 Application	3
1.4 Package Dimension	4
1.5 Product Parameters	5
1.6 Bin Range Of Forward Voltage and Luminous Flux and Dominant wavelength (IF=60mA)	6
1.7 Typical optical characteristics curves	7
2. Packaging	11
2.1 Packaging Specification	11
2.1.1 Carrier Tape Dimension	11
2.1.2 Reel Dimension	11
2.1.3 Label Form Specification	12
2.2 Moisture Resistant Packing	12
2.3 Cardboard Box.....	12
2.4 Reliability Test Items And Conditions.....	13
2.5 Criteria For Judging Damage.....	14
3. SMT Reflow Soldering Instructions.....	15
3.1 SMT Reflow Soldering Instructions.....	15
4. Handling Precautions	17
4.1 Handling Precautions.....	17



1. Description

1.1 General Description

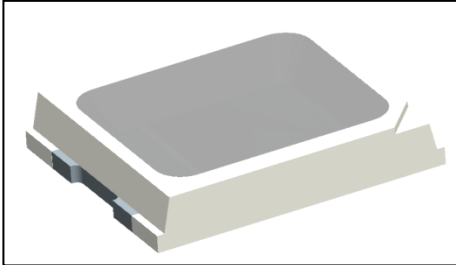

The Blue source color devices are made with InGaN on Substrate Light Emitting Diode.
Product package: 2.8mmX3.5mmX0.75mm。

1.2 Features

- ▶ PLCC Package.
- ▶ Extremely wide viewing angle.
- ▶ Suitable for all SMT assembly and solder process.
- ▶ Available on tape and reel.
- ▶ Moisture sensitivity level: Level 3
- ▶ RoHS compliant.

1.3 Application

- ▶ Hotel, markets, offices, household and other architectural uses.
- ▶ Optical indicator.
- ▶ Landscape lighting, lamp belt.
- ▶ General use.



1.4 Package Dimension

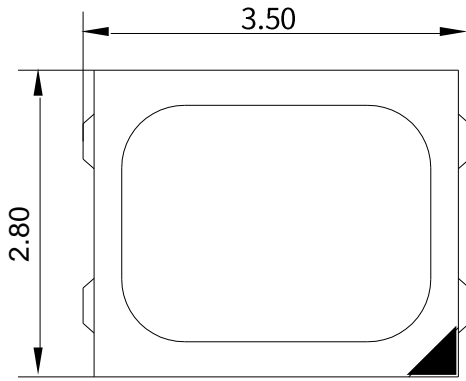

Fig.1-1 Top view

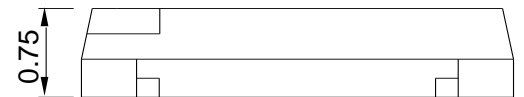

Fig.1-2 Side view

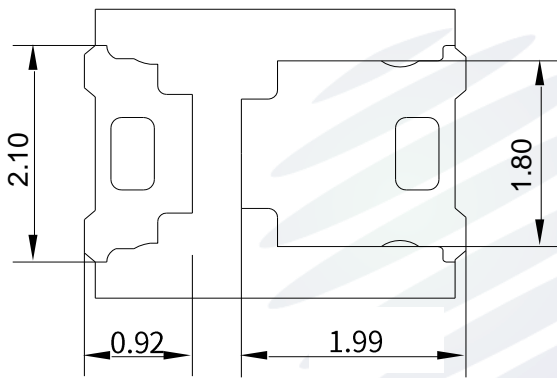

Fig.1-3 Bottom view

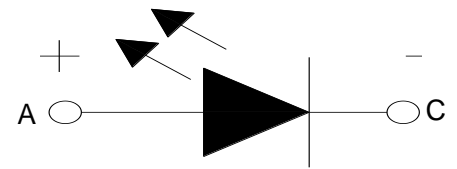

Fig.1-4 Polarity



Fig.1-5 Soldering patterns

Notes:

1. All dimensions units are millimeters.
2. All dimensions tolerances are $\pm 0.2\text{mm}$ unless otherwise noted.



1.5 Product Parameters

Table 1-1 Electrical / Optical Characteristics at Ts=25°C

Item	Symbol	Test Condition	Value			Unit
			Min.	Typ	Max.	
Forward Voltage	V_F	$I_F=60\text{mA}$	2.8	---	3.0	V
Reverse Current	I_R	$V_R=5\text{V}$	---	---	10	μA
RF-BNRI35TS-DF-N Luminous Intensity	I_v	$I_F=60\text{mA}$	700	---	950	mcd
Viewing Angle	2 θ 1/2	$I_F=60\text{mA}$	---	120	---	deg
Dominant wavelength	λ_d	$I_F=60\text{mA}$	450	---	455	nm
Thermal Resistance.	R_{THJ-S}	$I_F=60\text{mA}$	---	55	---	$^{\circ}\text{C/W}$

Table 1-2 Absolute Maximum Ratings at Ts=25°C

Parameter	Symbol	Rating	Units
Power Dissipation	P_D	210	mW
Forward Current	I_F	70	mA
Peak Forward Current	I_{FP}	150	mA
Reverse Voltage	V_R	5	V
Electrostatic Discharge	E_{SD}	2000	V
Operating Temperature	T_{OPR}	-40 ~ +85	$^{\circ}\text{C}$
Storage Temperature	T_{OPR}	-40 ~ +100	$^{\circ}\text{C}$

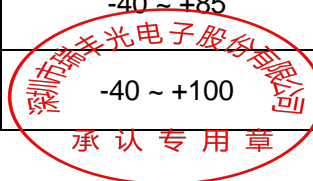

Junction Temperature	T _J	115	°C
----------------------	----------------	-----	----

Notes:

- 1/10 Duty cycle, 0.1ms pulse width.
- The above forward voltage measurement allowance tolerance is $\pm 0.1V$.
- The above wavelength measurement allowance tolerance is $\pm 1nm$.
- The above luminous flux measurement allowance tolerance $\pm 10\%$.
- Care is to be taken that power dissipation does not exceed the absolute maximum rating of the product.
- All measurements were made under the standardized environment of Refond.
- When the LEDs are in operation the maximum current should be decided after measuring the package temperature, junction temperature should not exceed the maximum rate.
- ESD yield is over 90% at 2000V ESD (HBM). ESD protection during products handling is needed.

1.6 Bin Range Of Forward Voltage and Luminous Flux and Dominant wavelength (IF=60mA)

Table 1-3

V _F (V)	G0
	2.8-3.0
RF-BNRI35TS-DF-N λ _d (nm)	A00
	450-455
RF-BNRI35TS-DF-N I _v (mcd)	I00
	700-950



1.7 Typical optical characteristics curves

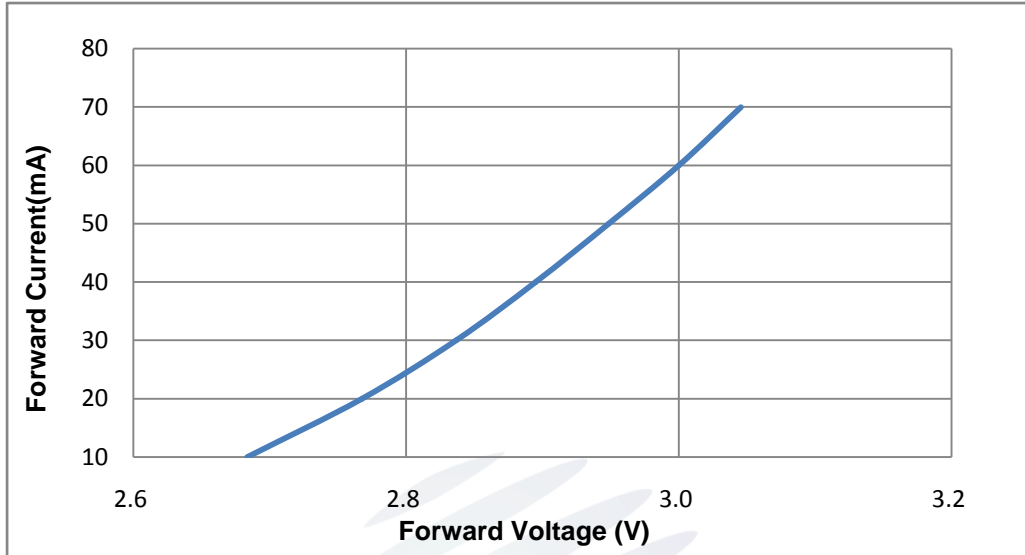

Fig 1-7 Forward Voltage Vs. Forward Current

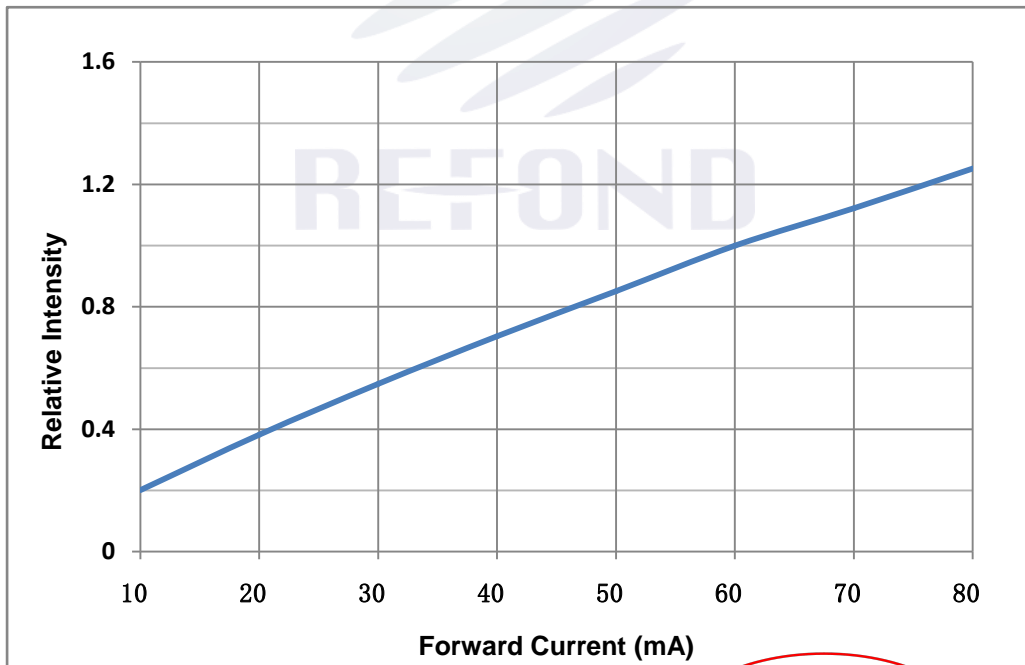
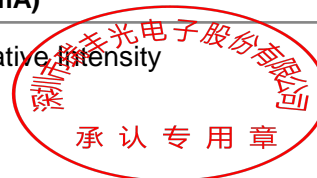

Fig 1-8 Forward Current Vs. Relative Intensity



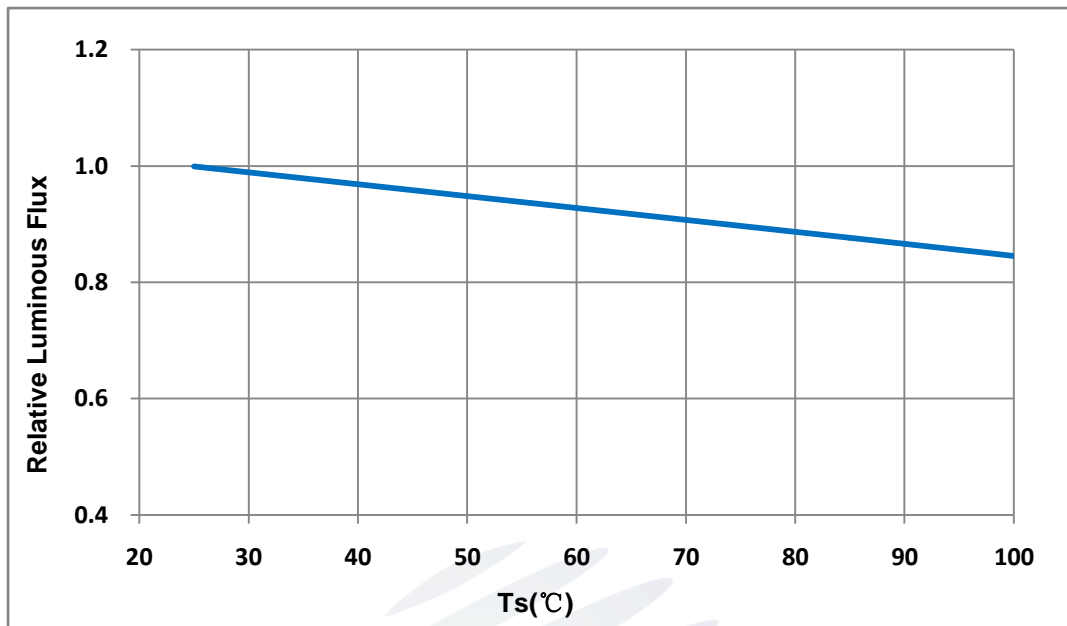

Fig 1-9 Solder Temperature Vs Relative Intensity

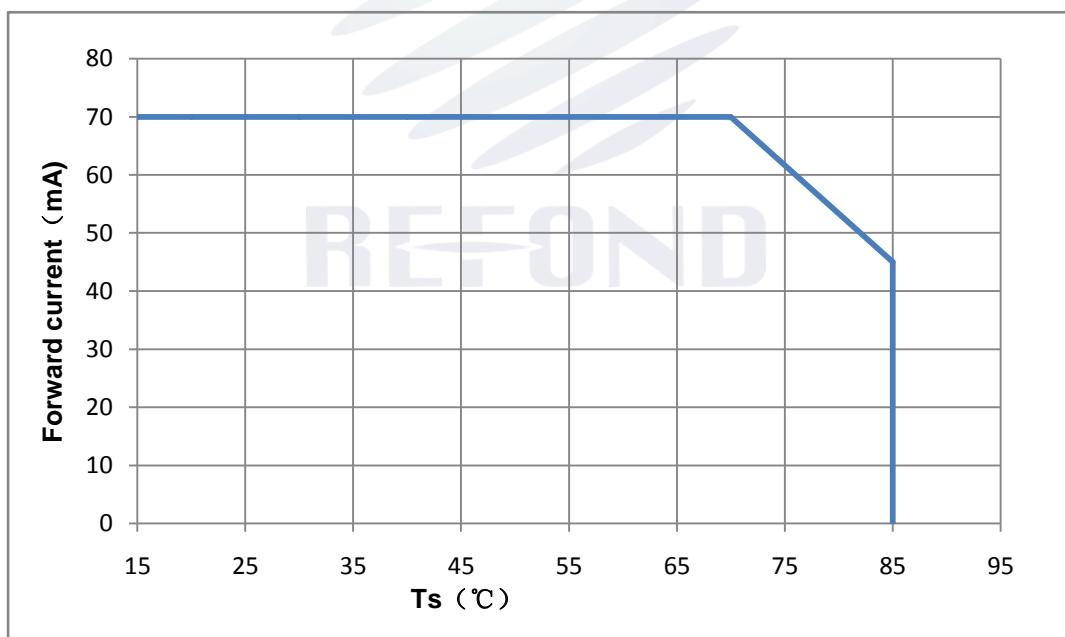

Fig 1-10 Solder Temperature Vs Forward Current



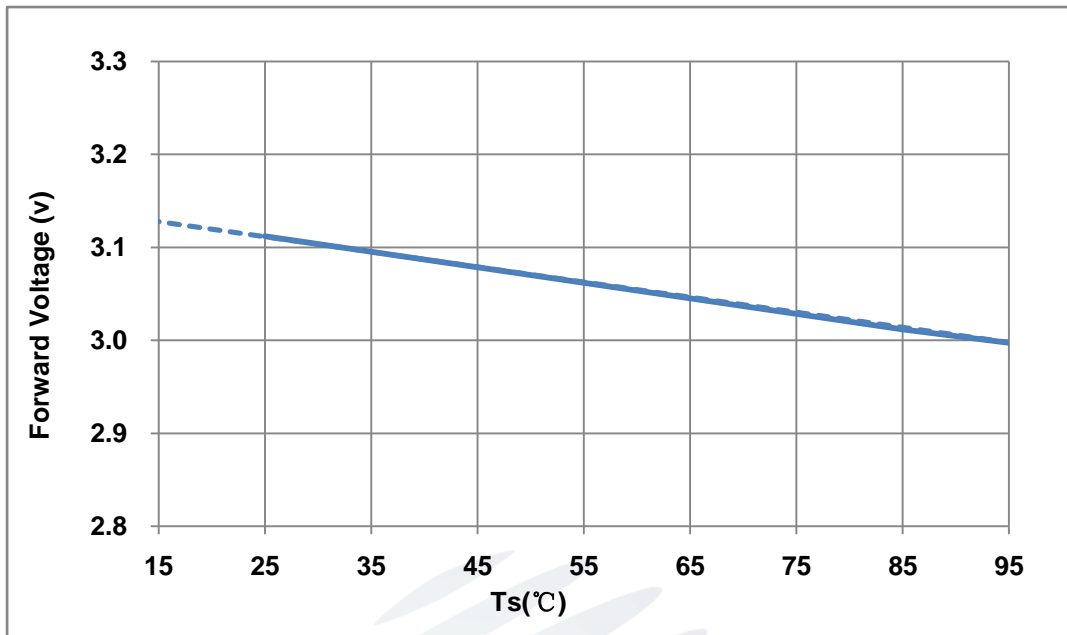

Fig 1-11 Forward Voltage Vs Solder Temperature

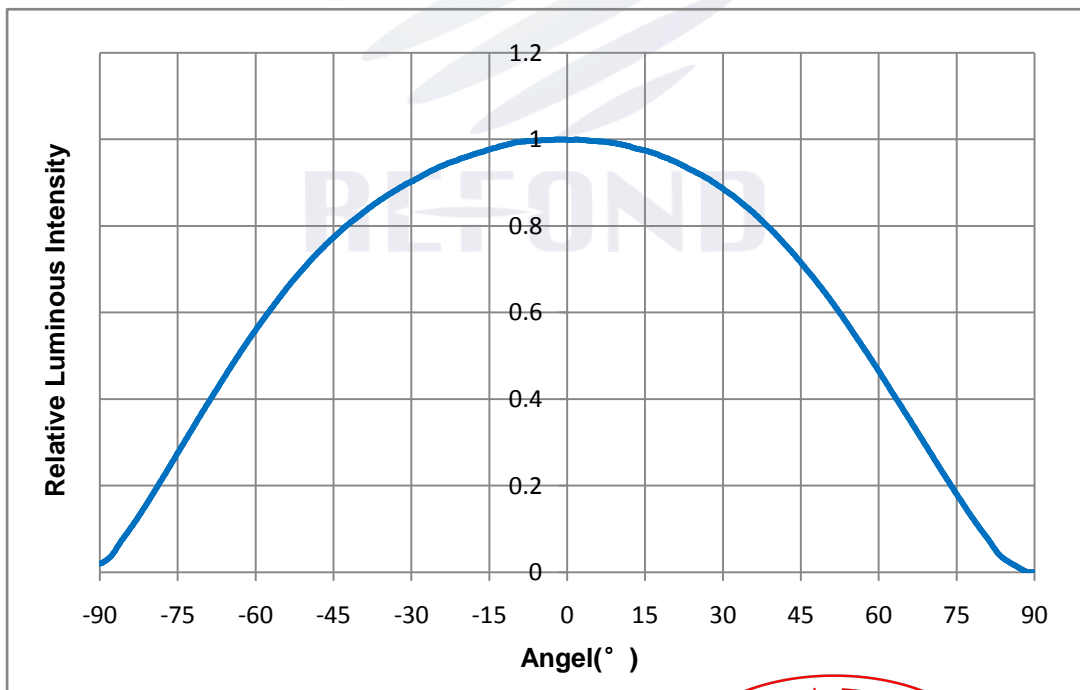

Fig 1-12 Radiation diagram



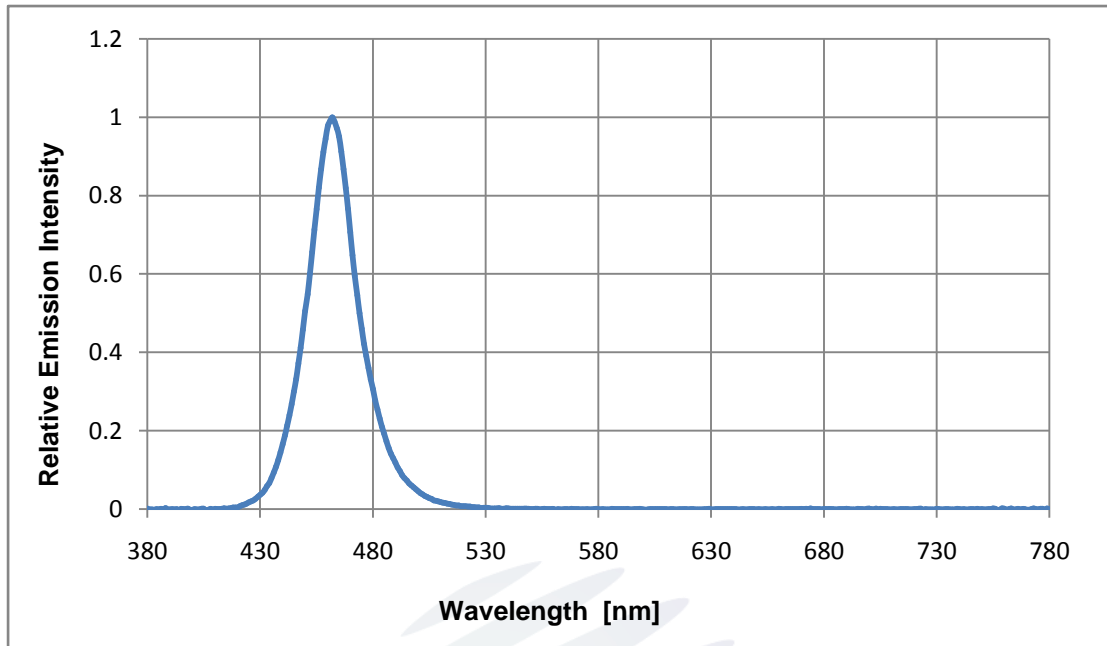

Fig 1-13 Spectrum Distribution

REFOND



2. Packaging

2.1 Packaging Specification

Package:Max 4000pcs/reel.

2.1.1 Carrier Tape Dimension

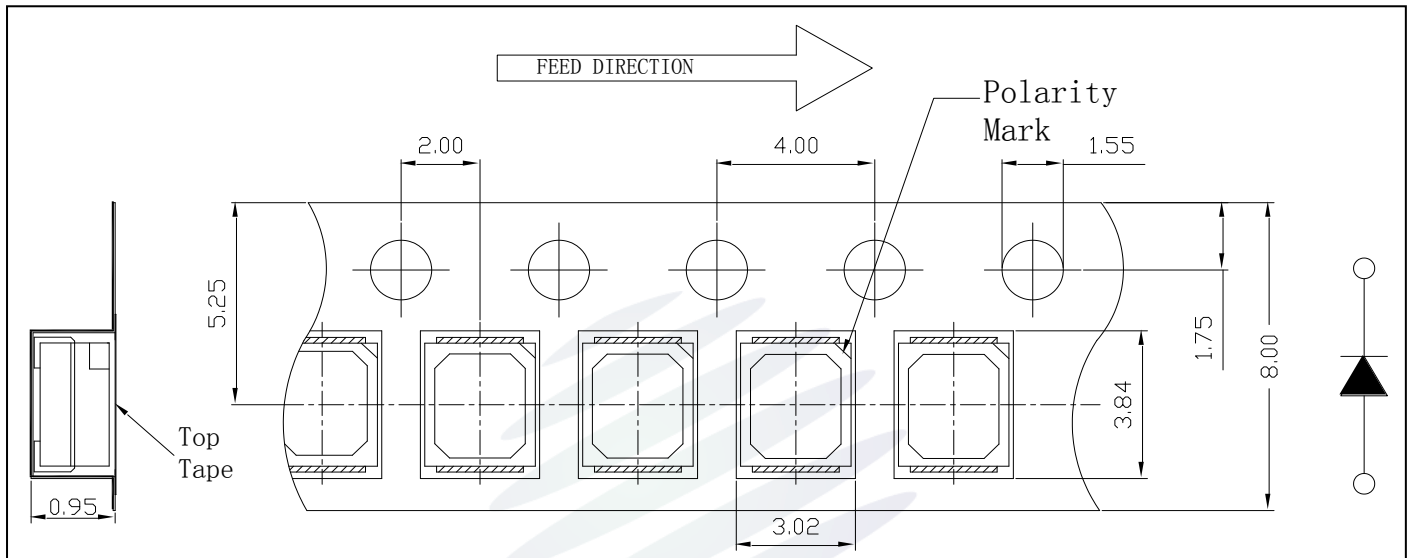

Fig.2-1 Carrier Tape Dimension

2.1.2 Reel Dimension

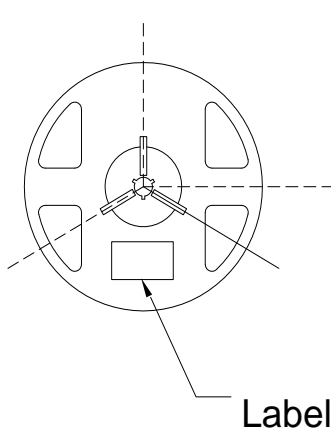

Fig.2-2 Reel

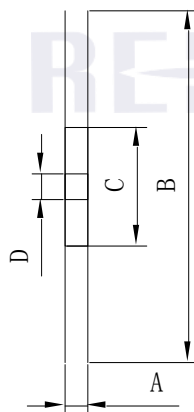

Table 2-1 Reel Dimension

A	10.5±0.5mm
B	178±1mm
C	59±1mm
D	13.5±0.5mm

Notes:

The tolerances unless mentioned $\pm 0.1\text{mm}$. Unit : mm



2.1.3 Label Form Specification

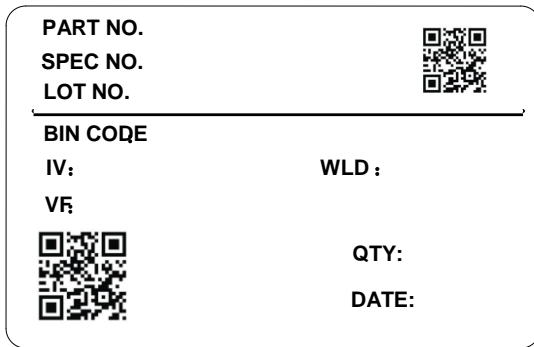

Fig 2-3 Label Form

Table 2-2 Label Parameter

PART NO.	Part Number
SPEC NO.	Spec Number
LOT NO.	Lot Number
BIN CODE	Bin Code
IV	Luminous Intensity
WLD	Dominant wavelength
V _F	Forward Voltage
QTY	Packing Quantity
DATE	Made Date

2.2 Moisture Resistant Packing

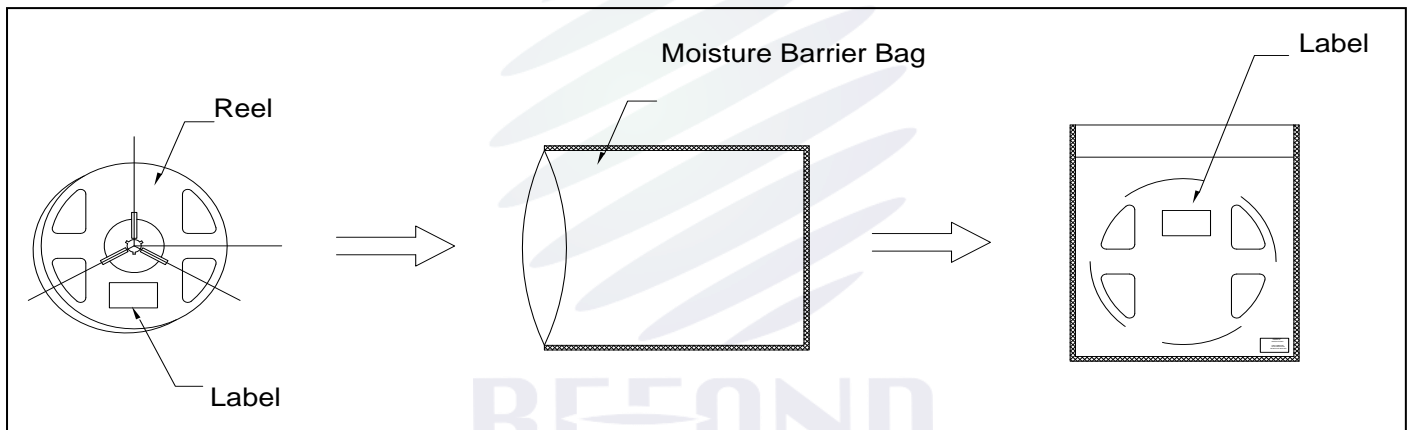

Fig.2-4 Packing specification

2.3 Cardboard Box

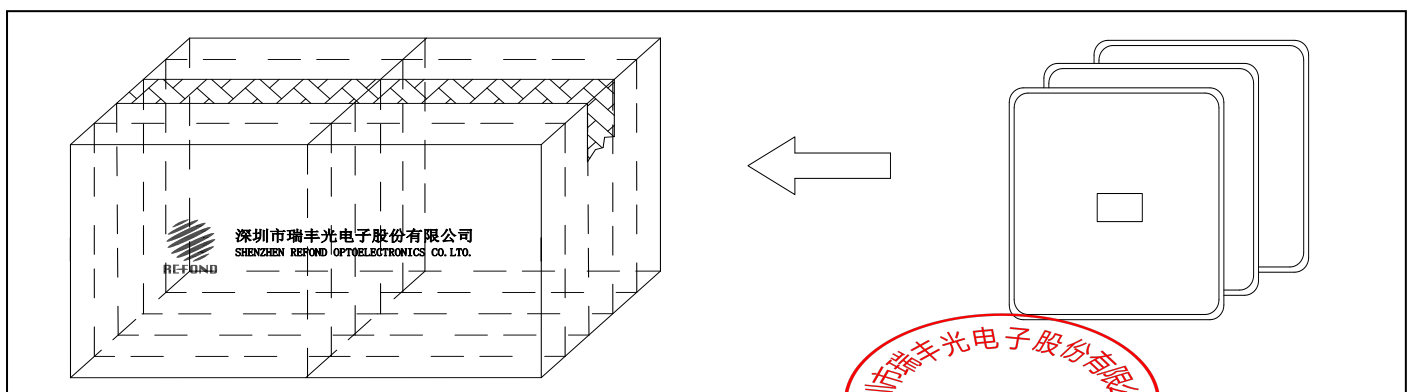
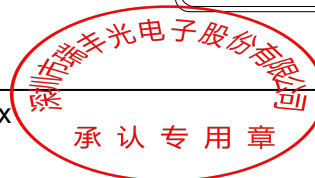

Fig.2-5 Cardboard Box



2.4 Reliability Test Items And Conditions

Table 2-3 Test items and conditions

TestItems	Ref.Standard	Test Condition	Time	Quantity	Ac/Re
Reflow	JESD22-B106	Temp:260°Cmax T=10 sec	2times	10pcs.	0/1
Thermal Shock	JESD22-A106	-40°C 15min ↑↓10s 100°C 15min	100 cycle	10pcs.	0/1
High Temperature Storage	JESD22-A103	Temp:100°C	1000hrs.	10pcs.	0/1
Low Temperature Storage	JESD22-A119	Temp:-40°C	1000hrs.	10pcs.	0/1
Life Test	JESD22-A108	Ta=25°C If=60mA	1000hrs.	10pcs.	0/1
High Temperature High Humidity Life Test	JESD22-A101	60°C/ 90%RH If=60mA	1000hrs.	10pcs.	0/1



2.5 Criteria For Judging Damage

Table 2-4 Criteria for judging damage

Test Items	Symbol	Test Condition	Criteria For Judgement	Applicable project
Forward Voltage	V_F	$I_F=60\text{mA}$	$\leq \pm 10\%$	Reflow
Luminous Intensity	I_v	$I_F=60\text{mA}$	Maintenance $\geq 70\%$	Thermal Shock High and Low Temperature Storage Life Test
Lamp Bead Light Test	/	$I_F=60\text{mA}$	No open circuit short circuit or flicke	High Temperature High Humidity Life Test

Notes:

- 1.U.S.L: Upper standard level. L.S.L: Lower standard level.
- 2.The above reliability tests are based on the verification of a single/strip LED of Refond's existing experimental platform,the reliability experimental was taken under good heat dissipation conditions.When customers applies the LED to the series and parallel circuit,should take consideration of all the factors such as the current,voltage distribution,heat dissipation and others.
- 3.The technical information shown in the data sheets are limited to the typical characteristics and circuit examples of the referenced products. It does not constitute the warranting of industrial property nor the granting of any license.



3. SMT Reflow Soldering Instructions

3.1 SMT Reflow Soldering Instructions

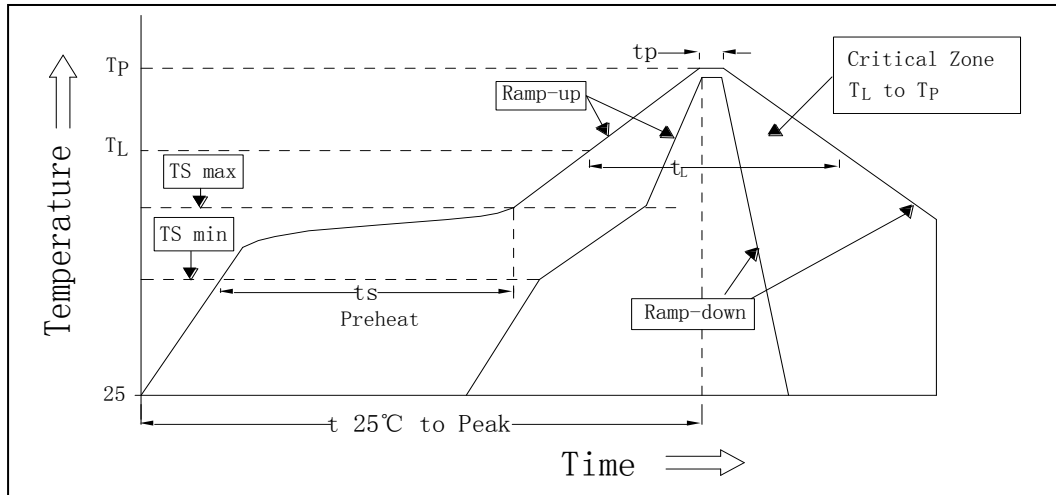

Fig.3-1 SMT Reflow Soldering Instructions

Table 3-1 SMT Reflow Soldering parameters SMT

Average temperature rise speed ($T_{S\ max}$ to T_p)	Max 3 °C/ s
Preheating: minimum temperature ($T_{S\ min}$)	150 °C
Preheating: Max temperature	200 °C
Preheating: Time	60s-120s
Time limited to maintain high temperature: the temperature (T_L)	217 °C
Time limited to maintain high temperature: The Time (t_L)	Max 60s
Peak /Classification of temperature: (T_p)	260 °C
Time limit classification of peak temperature time	Max 10s
Hold time within 5 °C with the actual peak temperature (T_p)	Max 30s
Cooling speed	Max 6 °C/ s
Needed time from 25 °C to T_p	Max 8 minutes



Notes:

(1)Reflow soldering should not be done more than two times. In the case of more than 24 hours passed soldering after first, LEDs will be damaged.

(2)Whensoldering , do not put stress on the LEDs during heating.

3.1.1 Soldering Iron

(1) When hand soldering, keep the temperature of iron below less 300℃ less than 3 seconds

(2) The hand solder should be done only one time.

3.1.2 Repairing

Repair should not be done after the LEDs have been soldered. When repairing is unavoidable,a double-head soldering iron should be used (as below figure). It should be confirmed in advance whether the characteristics of LEDs will or will not be damaged by repairing.

3.1.3 Cautions

(1) The encapsulated material of the LEDs is silicone. Therefore the LEDs have a soft surface on the top of package. The pressure to the top surface will be influence to the reliability of the LEDs. Precautions should be taken to avoid the strong pressure on the encapsulated part. So when use the picking up nozzle, the pressure on the silicone resin should be proper.

(2) Do not apply mechanical force or excess vibration during the cooling process to normal temperature after soldering. Do not rapidly cool device after soldering.



4. Handling Precautions

4.1 Handling Precautions

- (1) LED operating environment and sulfur element composition cannot be over 100PPM in the LED mating usage material. This is provided for informational purposes only and is not a warranty or endorsement.
- (2) In order to prevent external material from getting into the inside of LED, which may cause the malfunction of LED, the single content of Bromine element is required to be less than 900PPM, the single content of Chlorine element is required to be less than 900PPM, the total content of Bromine element and Chlorine element in the external materials of the application products is required to be less than 1500PPM. This is provided for informational purposes only and is not a warranty or endorsement.
- (3) VOCs (Volatile organic compounds) emitted from materials used in the construction of fixtures can penetrate silicone encapsulants of LEDs and discolor when exposed to heat and photonic energy. The result can be a significant loss of light output from the fixture. Knowledge of the properties of the materials selected to be used in the construction of fixtures can help prevent these issues. Refond advises against the use of any chemicals or materials that have been found or are suspected to have an adverse effect on device performance or reliability. To verify compatibility, Refond recommends that all chemicals and materials be tested in the specific application and environment for which they are intended to be used. Attaching LEDs, do not use adhesives that outgas organic vapor.
- (4) Handle the component along the side surface by using forceps or appropriate tools; do not directly touch or handle the silicone lens surface, it may damage the internal circuitry.

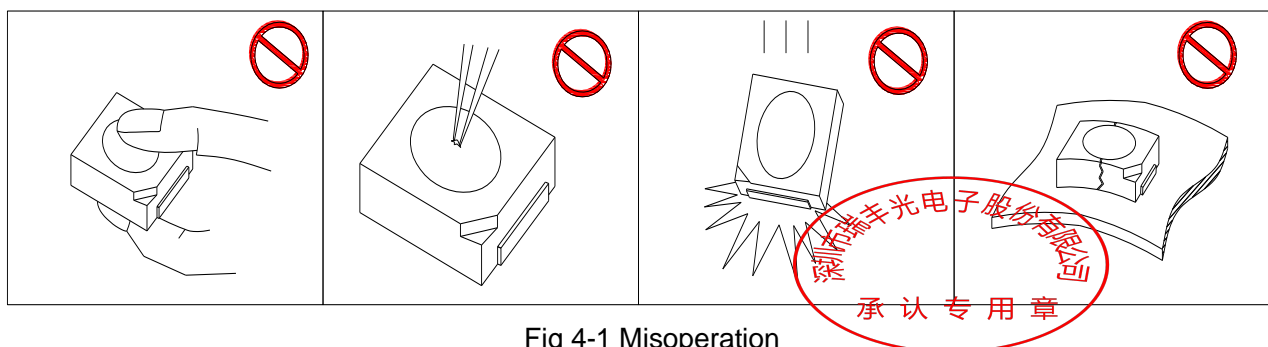

Fig 4-1 Misoperation

(5) In designing a circuit, the current through each LED can not be exceed the absolute maximum rating specified for each LED. In the meanwhile, resistors for protection should be applied, otherwise slight voltage shift will cause big current change, burn out may happen. The driving circuit must be designed to allow forward voltage only when it is ON or OFF. If the reverse voltage is applied to LED, migration can be generated resulting in LED damage.

(6) Thermal Design is paramount importance because heat generation may result in the Characteristics decline, such as brightness decreased, Color change and so on. Please consider the heat generation of the LEDs when making the system design.

(7) Compared to standard encapsulants, silicone is generally softer, and the surface is more likely to attract dust, requiring special care during processing. In cases where a minimal level of dirt and dust particles cannot be guaranteed, a suitable cleaning solution must be applied to the surface after the soldering of components. Refond suggests using isopropyl alcohol for cleaning. In case other solvents are used, it must be assured that these solvents do not dissolve the package or resin. Ultrasonic cleaning is not recommended. Ultrasonic cleaning may cause damage to the LED.

Table 4-1 Storage

Conditions		Temperature	Humidity	Time
Storage	Before Opening Aluminum Bag	≤30°C	≤75%	Within 1 Year From Date
	After Opening Aluminum Bag	≤30°C	≤60%	24hours
Baking		60±5°C	-	≥24hours

(8) If the moisture absorbent material (silica gel) has faded away or the LEDs have exceeded the storage time, baking treatment should be performed after unpacking and based on the following condition (60±5) °C for above 24 hours.



If the package is flatulence or damaged, please notify the sales staff to assist.

(9) Similar to most Solid state devices; LEDs are sensitive to Electro-Static Discharge (ESD) and Electrical Over Stress (EOS).

(10) Other points for attention, please refer to our relevant information.



