

SPECIFICATION

REFOND P/N

RF-Q30RA**B-24-J2

R&D

Mass Product



Contents

1. Description	3
1.1 General Description.....	3
1.2 Features	3
1.3 Application	3
1.4 Package Dimension	4
1.5 Product Parameters	5
1.6 The C.I.E Chromaticity Diagram CIE.....	7
1.7 Typical optical characteristics curves	9
2. Packaging	13
2.1 Packaging Specification	13
2.1.1 Carrier Tape Dimension	13
2.1.2 Reel Dimension	13
2.1.3 Label Form Specification	14
2.2 Moisture Resistant Packing	14
2.3 Cardboard Box.....	14
2.4 Reliability Test Items And Conditions.....	15
2.5 Criteria For Judging Damage.....	15
3. SMT Reflow Soldering Instructions.....	16
3.1 SMT Reflow Soldering Instructions.....	16
4. Handling Precautions	18
4.1 Handling Precautions.....	18



1. Description

1.1 General Description

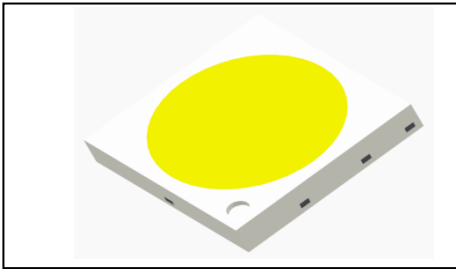

The White LED which was fabricated using a blue chip and the phosphor
3.0mmX3.0mmX0.55mm。

1.2 Features

- ▶ EMC Package.EMC.
- ▶ Extremely wide viewing angle.
- ▶ Suitable for all SMT assembly and solder process.
- ▶ Package:5000pcs/reel.
- ▶ Moisture sensitivity level: Level 3.
- ▶ RoHS compliant.

1.3 Application

- ▶ Optical indicator.
- ▶ Indoor display.
- ▶ Outdoor lighting
- ▶ General use.



1.4 Package Dimension

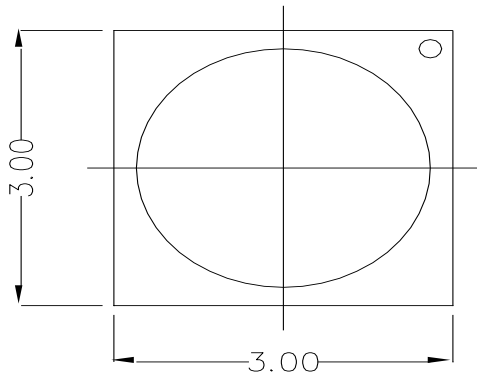

Fig.1-1 Top view

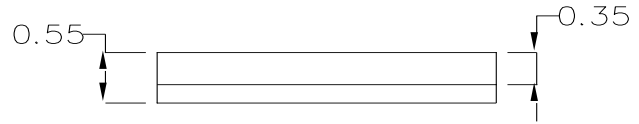

Fig.1-2 Side view

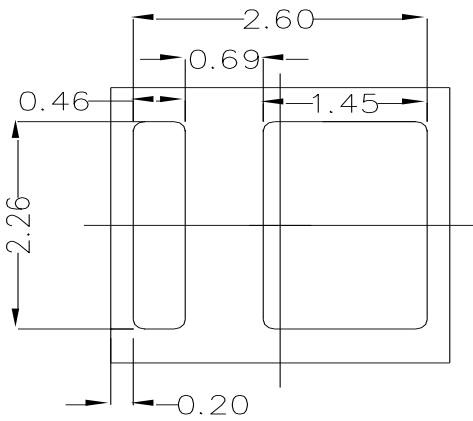
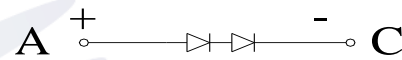

Fig.1-3 Bottom view



Polarity
A: anode
C: cathode

Fig.1-4 Polarity

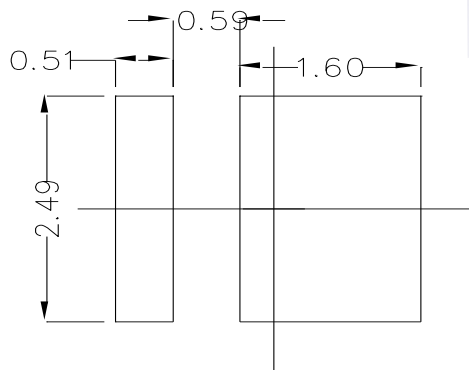

Fig.1-5 Soldering patterns

Notes:

1. All dimensions units are millimeters.
2. All dimensions tolerances are $\pm 0.05\text{mm}$ unless otherwise noted.



1.5 Product Parameters

Table 1-1 Electrical / Optical Characteristics at Ts=25°C

Product		Symbol	test condition	Value			unit
				Min.	Max.	Typ.	
Forward Voltage	Rank R1	Vf	If =150mA	5.8	6.0	---	V
	Rank R2			6.0	6.2	---	V
	Rank S1			6.2	6.4	---	V
RF-Q30RA27B-24-J2 (2575-2865K)	Rank FC4	Φ	If =150mA	120	130	128	lm
	Rank FC5			130	140		lm
RF-Q30RA30B-24-J2 (2865-3215K)	Rank FC4	Φ	If =150mA	120	130	135	lm
	Rank FC5			130	140		lm
	Rank FC6			140	150		lm
RF-Q30RA40B-24-J2 (3660-4195K)	Rank FC5	Φ	If =150mA	130	140	145	lm
	Rank FC6			140	150		lm
	Rank FC7			150	160		lm
RF-Q30RA50B-24-J2 (4600-5100K)	Rank FC5	Φ	If =150mA	130	140	145	lm
	Rank FC6			140	150		lm
	Rank FC7			150	160		lm
RF-Q30RA57B-24-J2 (5100-5790K)	Rank FC5	Φ	If =150mA	130	140	145	lm
	Rank FC6			140	150		lm
	Rank FC7			150	160		lm
RF-Q30RA65B-24-J2 (5790-6575K)	Rank FC5	Φ	If =150mA	130	140	145	lm
	Rank FC6			140	150		lm
	Rank FC7			150	160		lm
Reverse Current		IR	Vr=10V	---	10	---	uA
Viewing Angle		2Θ1/2	If =150mA	---	---	110	Deg
Color Rendering Index		Ra	If =150mA	80	---	82	---
Thermal resistance		R _{THJ-S}	If =150mA	---	---	---	°C/W

Table 1-2 Absolute Maximum Ratings at Ts=25°C

Parameter	Symbol	Rating	Units
Power Dissipation	P _D	1200	mW
Forward Current	I _F	180	mA
Peak Forward Current	I _{FP}	240	mA
Reverse Voltage	V _R	10	V
Electrostatic Discharge(HBM)	E _{SD}	2000	V
Operating Temperature	T _{OPR}	-40 ~ +100	°C
Storage Temperature	T _{OPR}	-40 ~ +100	°C
Junction Temperature	T _J	125	°C

Notes:

- 1/10 Duty cycle, 0.1ms pulse width. 2. The above forward voltage measurement allowance tolerance is $\pm 0.1V$.
3. The above color coordinates measurement allowance tolerance is ± 0.003
4. The above luminous intensity measurement allowance tolerance $\pm 10\%$.
5. Care is to be taken that power dissipation does not exceed the absolute maximum rating of the product.
6. All measurements were made under the standardized environment of Refond.
7. When the LEDs are in operation the maximum current should be decided after measuring the package temperature, junction temperature should not exceed the maximum rate.
8. ESD yield is over 90% at 2000V ESD (HBM). ESD protection during products handling is needed.



1.6 The C.I.E Chromaticity Diagram CIE

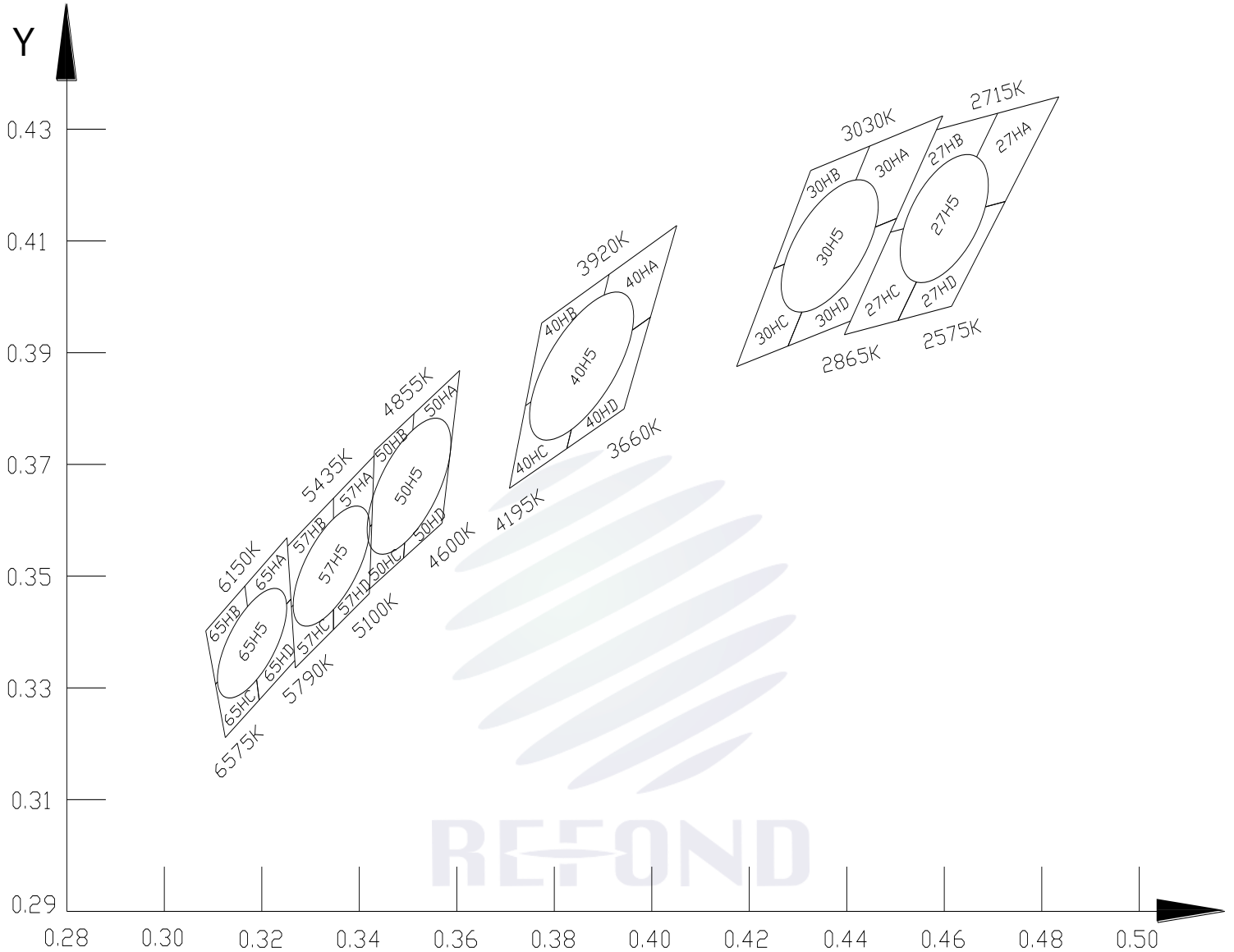

Fig 1-6 The C.I.E Chromaticity Diagram CIE



Bin data:

ANSI 5-Step										
Bin Code	X	Y	a	b	θ					
27H5	0.4600	0.4140	0.01350	0.00700	53°42'					
30H5	0.4365	0.4091	0.01390	0.00680	53°13'					
40H5	0.3856	0.3876	0.01565	0.00670	53°43'					
50H5	0.3502	0.3661	0.01370	0.00590	59°37'					
57H5	0.3343	0.3518	0.01243	0.00533	59°09'					
65H5	0.3180	0.3380	0.01561	0.00665	58°34'					
ANSI 7-Step										
Bin Code	X1	Y1	X2	Y2	X3	Y3	X4	Y4	X5	Y5
27HA	0.4835	0.4358	0.4725	0.4171	0.4684	0.4161	0.4666	0.4250	0.4710	0.4329
27HB	0.4710	0.4329	0.4666	0.4250	0.4517	0.4122	0.4488	0.4114	0.4583	0.4298
27HC	0.4517	0.4122	0.4543	0.4026	0.4505	0.3958	0.4359	0.3932	0.4490	0.4116
27HD	0.4684	0.4161	0.4725	0.4171	0.4615	0.3983	0.4505	0.3958	0.4543	0.4026
30HA	0.4597	0.4324	0.4502	0.4140	0.4458	0.4125	0.4419	0.4209	0.4447	0.4210
30HB	0.4447	0.4210	0.4419	0.4209	0.4272	0.4058	0.4250	0.4051	0.4326	0.4226
30HC	0.4250	0.4051	0.4272	0.4058	0.4308	0.3973	0.4279	0.3912	0.4174	0.3875
30HD	0.4458	0.4125	0.4725	0.4171	0.4408	0.3957	0.4279	0.3912	0.4308	0.3973
40HA	0.4051	0.4128	0.3997	0.3963	0.3960	0.3940	0.3902	0.4003	0.3913	0.4040
40HB	0.3913	0.4040	0.3902	0.4003	0.3752	0.3812	0.3741	0.3805	0.3774	0.3953
40HC	0.3741	0.3805	0.3752	0.3812	0.3835	0.3762	0.3826	0.3728	0.3708	0.3657
40HD	0.3960	0.3940	0.3997	0.3963	0.3943	0.3799	0.3826	0.3728	0.3835	0.3762
50HA	0.3606	0.3868	0.3587	0.3726	0.3510	0.3762	0.3512	0.3791	/	/
50HB	0.3512	0.3791	0.3510	0.3762	0.3428	0.3641	0.3431	0.3724	/	/
50HC	0.3424	0.3551	0.3493	0.3532	0.3491	0.3532	0.3421	0.3477	/	/
50HD	0.3586	0.3719	0.3570	0.3595	0.3491	0.3532	0.3493	0.3559	/	/
57HA	0.3431	0.3716	0.3426	0.3592	0.3422	0.3589	0.3347	0.3603	0.3347	0.3640
57HB	0.3347	0.3640	0.3347	0.3603	0.3264	0.3448	0.3261	0.3445	0.3253	0.3554
57HC	0.3261	0.3445	0.3264	0.3448	0.3347	0.3440	0.3347	0.3404	0.3269	0.3336
57HD	0.3422	0.3589	0.3426	0.3592	0.3421	0.3469	0.3347	0.3404	0.3347	0.3440
65HA	0.3252	0.3569	0.3260	0.3459	0.3251	0.3450	0.3171	0.3445	0.3165	0.3482
65HB	0.3165	0.3482	0.3171	0.3445	0.3109	0.3311	0.3105	0.3307	0.3085	0.3402
65HC	0.3105	0.3307	0.3109	0.3311	0.3189	0.3315	0.3195	0.3278	0.3125	0.3211
65HD	0.3251	0.3450	0.3260	0.3459	0.3268	0.3349	0.3195	0.3278	0.3189	0.3315

1.7 Typical optical characteristics curves

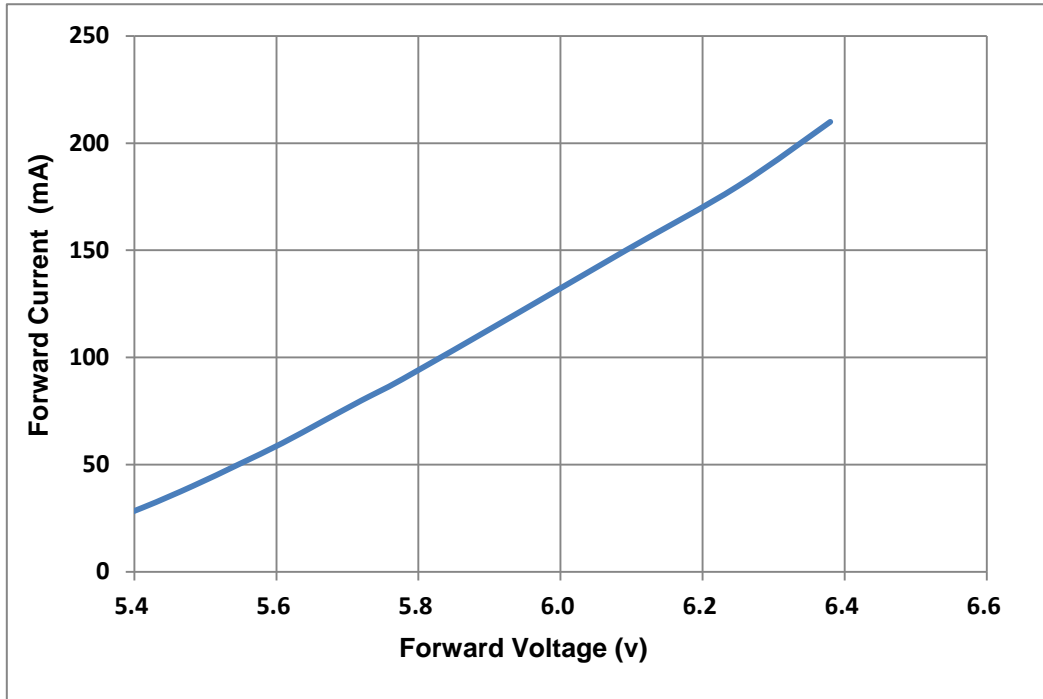

Fig 1-7 Forward Voltage Vs. Forward Current

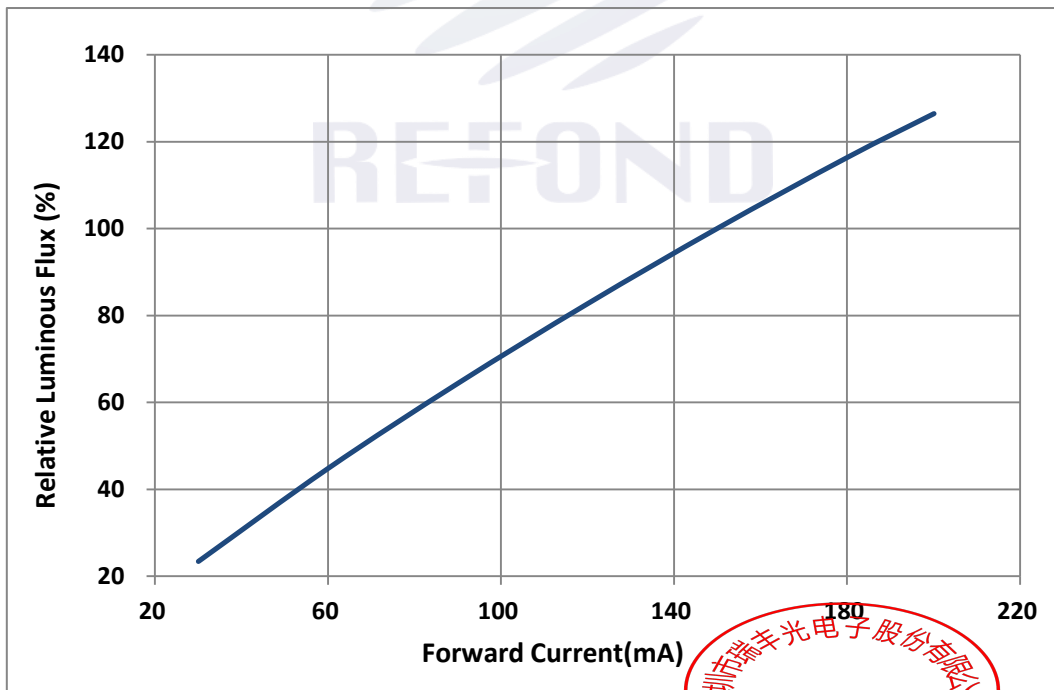

Fig 1-8 Forward Current Vs. Relative Intensity

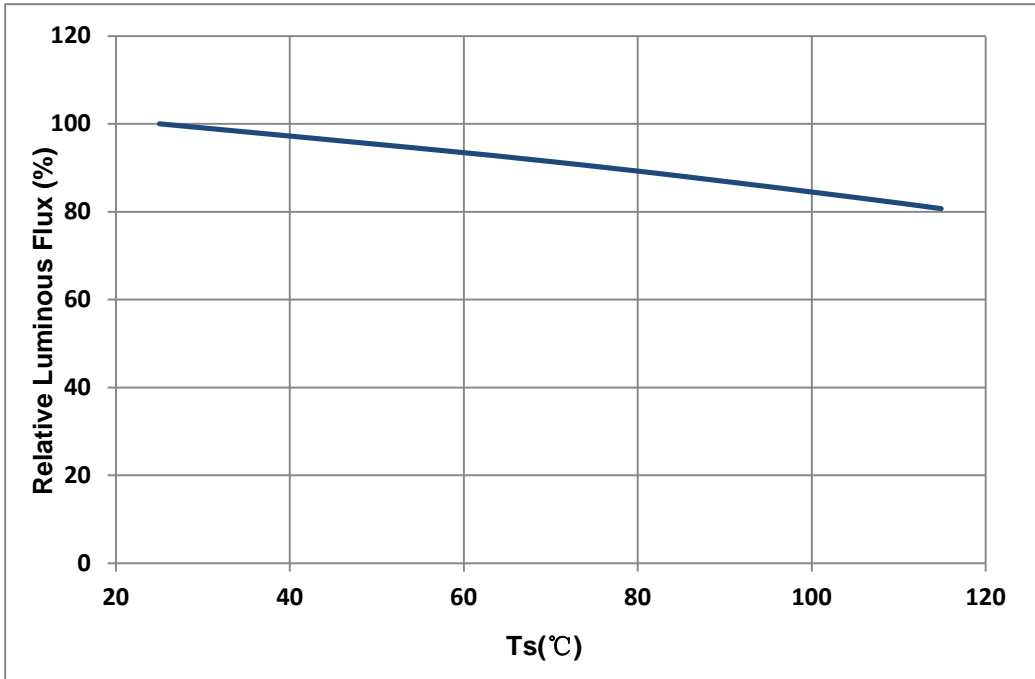

Fig 1-9 Solder Temperature Vs Relative Intensity

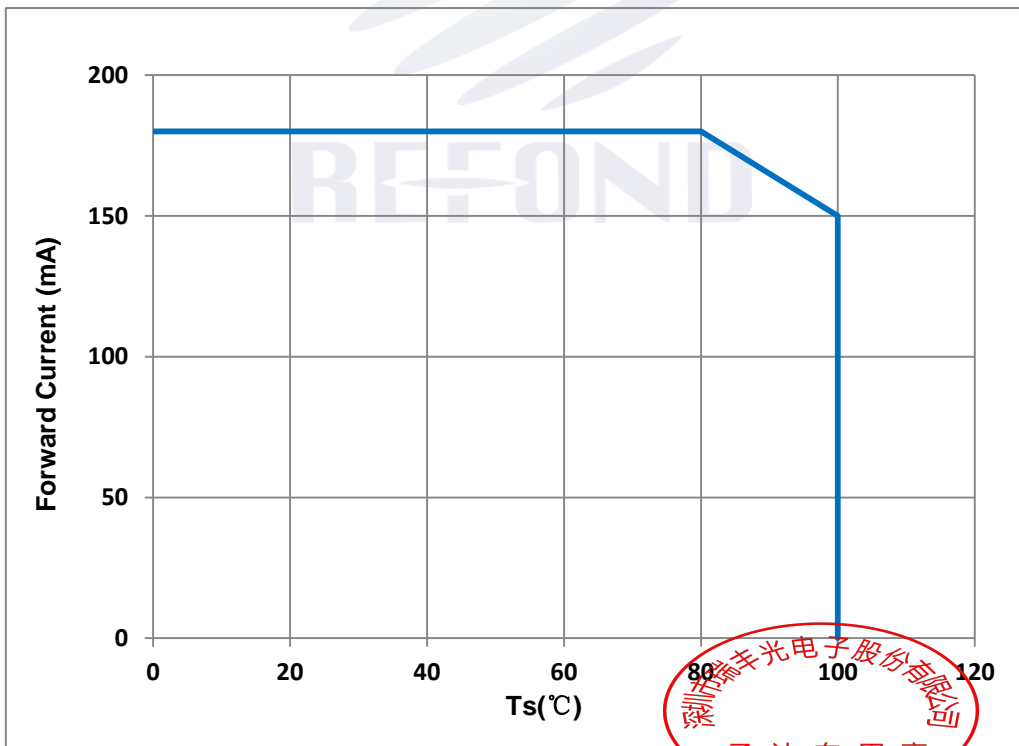

Fig 1-10 Solder Temperature Vs Forward Current

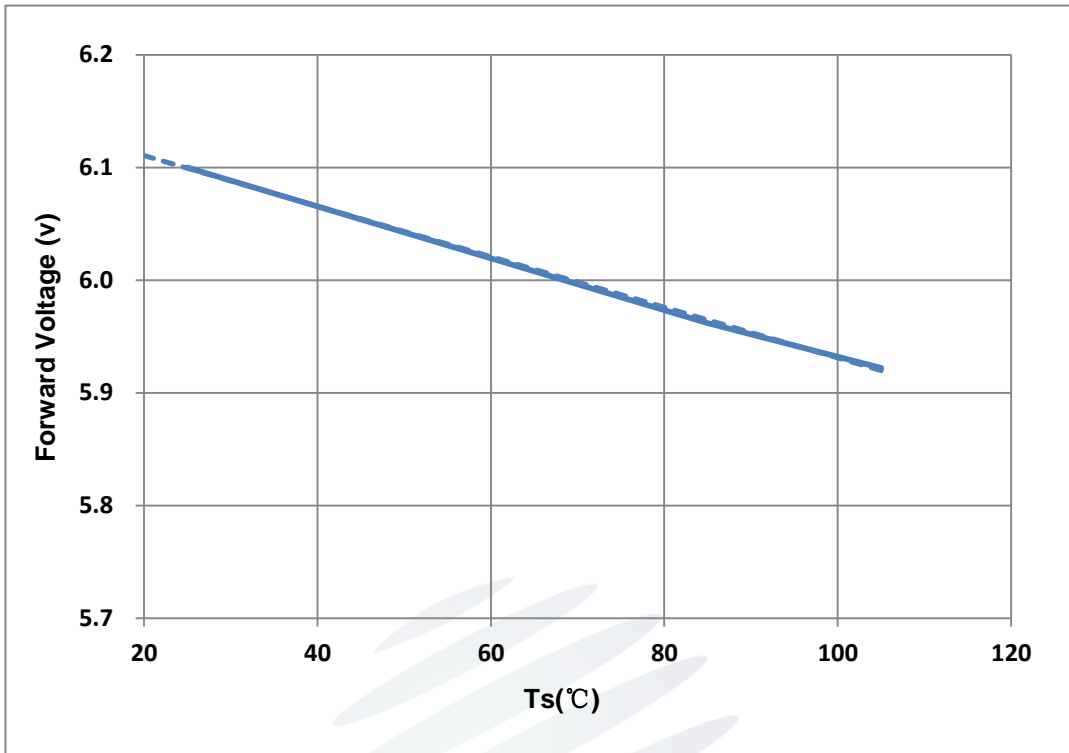

Fig 1-11 Forward Voltage Vs Solder Temperature

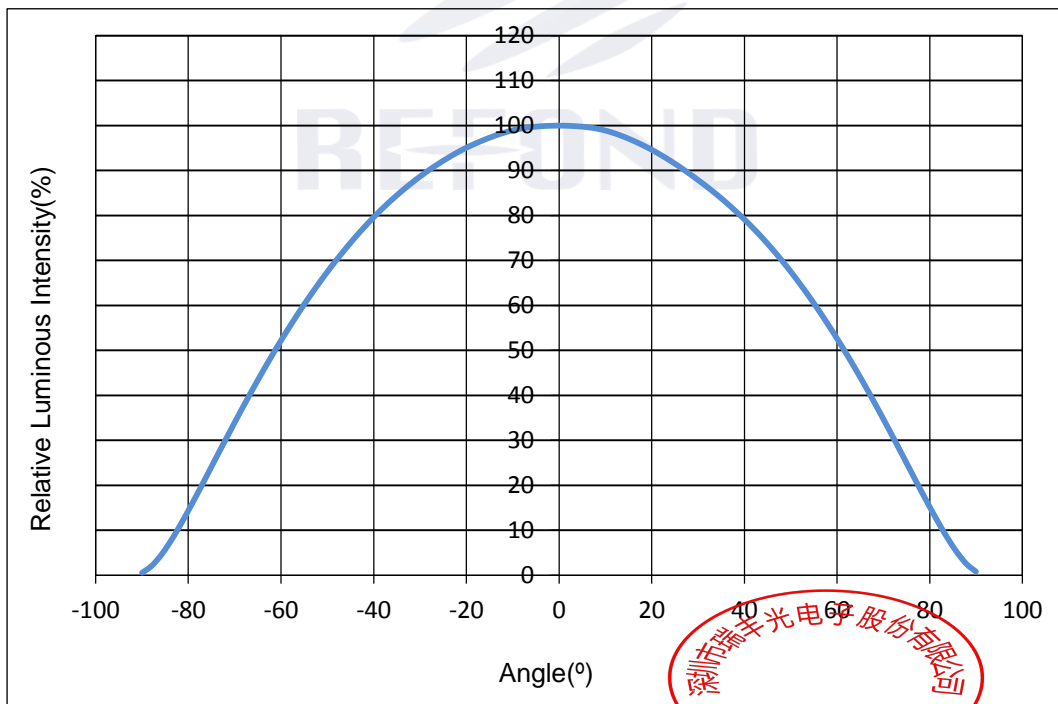

Fig 1-12 Radiation diagram

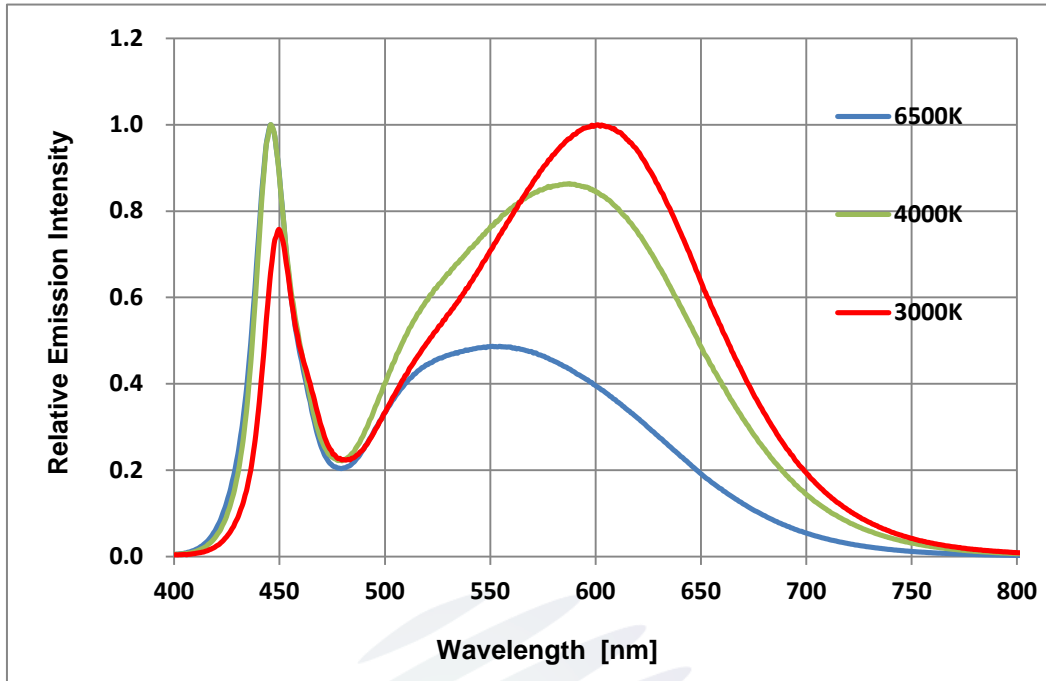

Fig 1-13 Spectrum Distribution

REFOND



2. Packaging

2.1 Packaging Specification

Package:5000pcs/reel.

2.1.1 Carrier Tape Dimension

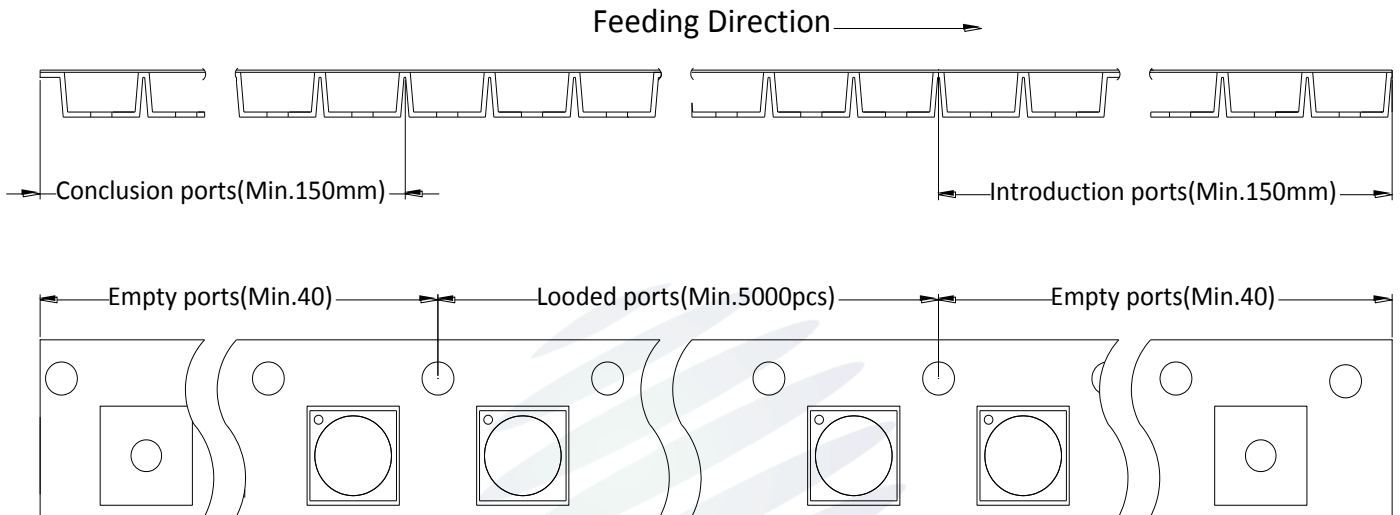
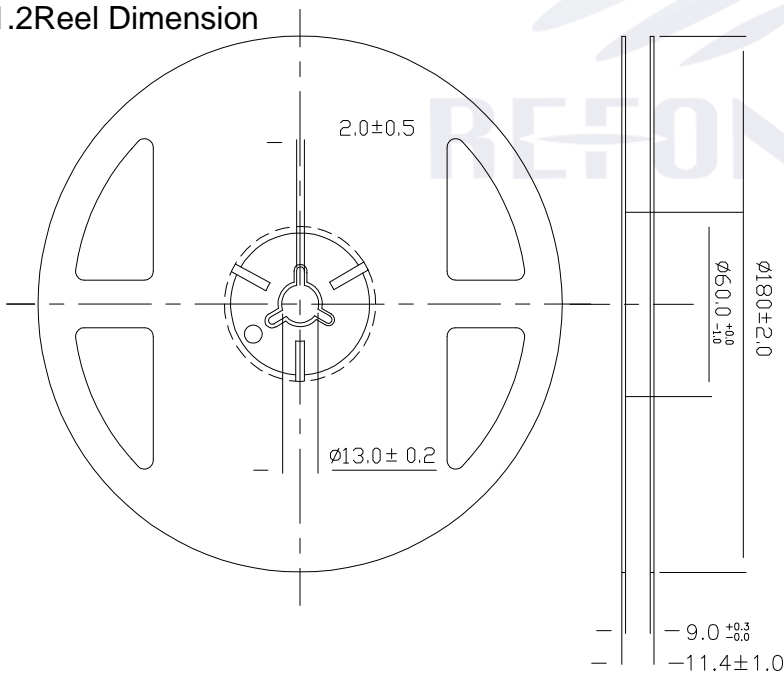

Fig.2-1 Carrier Tape Dimension

2.1.2 Reel Dimension



Notes:

The tolerances unless mentioned $\pm 0.1\text{mm}$. Unit : mm



2.1.3 Label Form Specification

PART NO:		
SPEC NO:		
LOT NO		
BIN CODE:		
Φ:	XY:	
VF:	WLD:	
	QTY:	
	DATE:	

Fig 2-3 Title

Table 2-2 Title

PART NO.	Part Number
SPEC NO.	Spec Number
LOT NO.	Lot Number
BIN CODE	Bin Code
Φ	Luminous flux
XY	Chromaticity Bin
V _F	Forward Voltage
WLD	Wavelength
QTY	Packing Quantity
DATE	Made Date

2.2 Moisture Resistant Packing

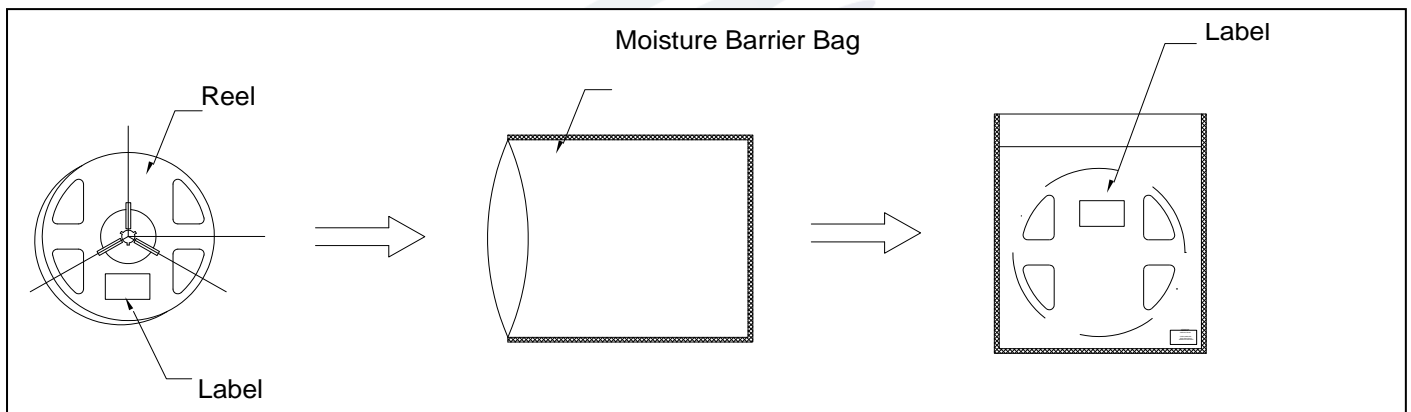

Fig.2-4Title

2.3 Cardboard Box

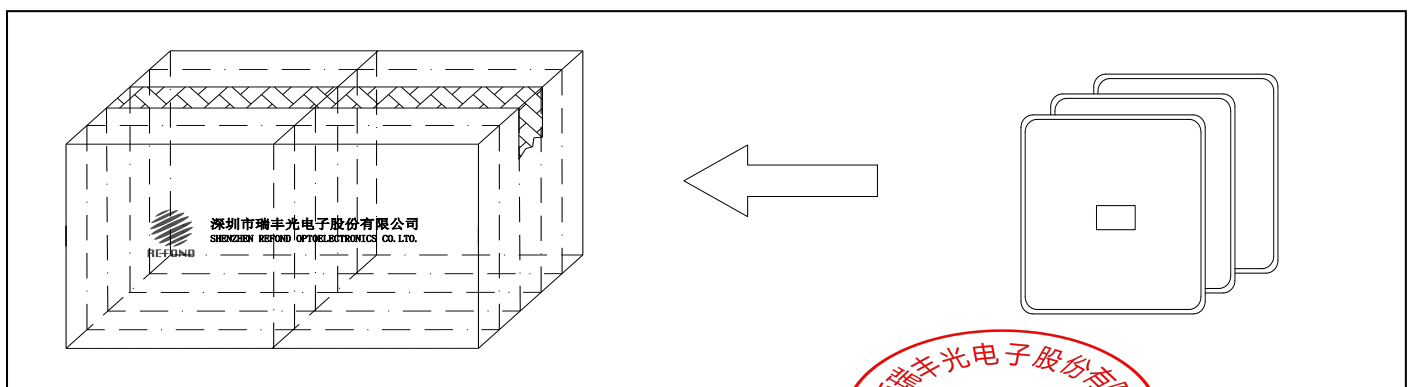

Fig.2-5Title



2.4 Reliability Test Items And Conditions

Table 2-3 Title

Test Items	Ref.Standard	Test Condition	Time	Quantity	Ac/Re
Reflow	JESD22-B106	Temp:260°C max T=10 sec	2times.	10Pcs.	0/1
Temperature Cycle	JESD22-A104	100°C 30 min. ↑↓5 min -40°C 30 min.	300Cycles	10Pcs.	0/1
Thermal Shock	JESD22-A106	-40°C 15min ↑↓10sec 100°C 15min	300Cycles	10Pcs.	0/1
High Temperature Storage	JESD22-A103	Temp.:105°C	1000Hrs.	10Pcs.	0/1
Low Temperature Storage	JESD22-A119	Temp.: -40°C	1000Hrs.	10Pcs.	0/1
Life Test	JESD22-A108	Ta=25°C If=150mA	1000Hrs.	10Pcs.	0/1
High Temperature High Humidity Life Test	JESD22-A101	60°C/ 90%RH If=150mA	1000Hrs.	10Pcs.	0/1

2.5 Criteria For Judging Damage

Table 2-4 Title

Test Items	Symbol	Test Condition	Criteria For Judgement	
			Min.	Max.
Forward Voltage	V _F	I _F =150mA	-	(U.S.L*)x1.1
Reverse Current	I _R	V _R =10V	-	(U.S.L*)x2.0
Luminous Flux	Φ	I _F =150mA	(L.S.L*)x0.7	-

Notes:

1. U.S.L: Upper standard level L.S.L: Lower standard level
2. The above reliability tests is based on the verification of a single/strip LED of Refond's existing experimental platform, the reliability experiment was taken under good heat dissipation conditions, when customers applies the LED to the series and parallel circuit, should take consideration of all the factors such as the current,

voltage distribution, heat dissipation and others.

3.The technical information shown in the data sheets are limited to the typical characteristics and circuit examples of the referenced products. It does not constitute the warranting of industrial property nor the granting of any license.

3. SMT Reflow Soldering Instructions

3.1 SMT Reflow Soldering Instructions

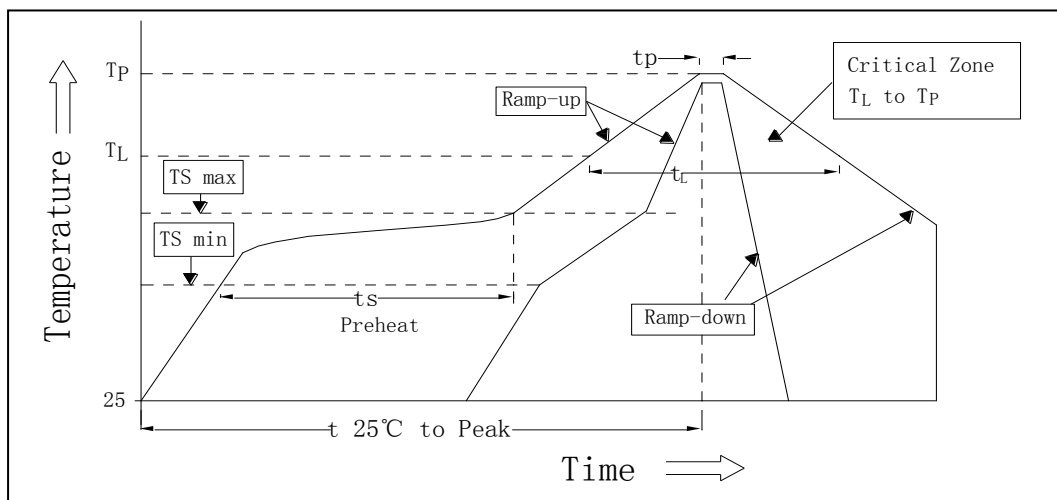

Fig.3-1Title

Table 3-1Title

Average temperature rise speed	Max 3 °C/ s
Preheating: minimum temperature	150 °C
Preheating: Max temperature	200 °C
Preheating: Time	60 - 120 60s-120s
Time limited to maintain high temperature: the temperature	217 °C
Time limited to maintain high temperature: The Time	Max 60s



Peak /Classification of temperature:	260 °C
Time limit classification of peak temperature time	Max 10s
Hold time within 5 °C with the actual peak temperature (TP)	Max 30s
Cooling speed	Max 6 °C/ s
Needed time from 25 °C to Tp	Max 8 minutes

Notes :

(1)Reflow soldering should not be done more than two times. In the case of more than 24 hours passed soldering after first, LEDs will be damaged.

(2)When soldering , do not put stress on the LEDs during heating. Soldering Iron When hand soldering, keep the temperature of iron below less 300°C less than 3 seconds

3.1.1 The hand solder should be done only one time. Repairing Repair should not be done after the LEDs have been soldered. When repairing is unavoidable, a double-head soldering iron should be used (as below figure). It should be confirmed in advance whether the characteristics of LEDs will or will not be damaged by repairing.

3.1.2 Cautions

(1) The encapsulated material of the LEDs is silicone. Therefore the LEDs have a soft surface on the top of package. The pressure to the top surface will be influence to the reliability of the LEDs. Precautions should be taken to avoid the strong pressure on the encapsulated part. So when use the picking up nozzle, the pressure on the silicone resin should be proper.

(2) Components should not be mounted on warped (non coplanar) portion of PCB. After soldering, do not warp the circuit board.

(3) Do not apply mechanical force or excess vibration during the cooling process to normal temperature after soldering. Do not rapidly cool device after soldering.

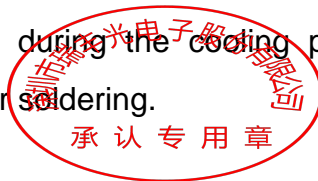

4. Handling Precautions

4.1 Handling Precautions

(1) LED operating environment and sulfur element composition cannot be over 100PPM in the LED mating usage material. This is provided for informational purposes only and is not a warranty or endorsement

(2) In order to prevent external material from getting into the inside of LED, which may cause the malfunction of LED, the single content of Bromine element is required to be less than 900PPM, the single content of Chlorine element is required to be less than 900PPM, the total content of Bromine element and Chlorine element in the external materials of the application products is required to be less than 1500PPM. This is provided for informational purposes only and is not a warranty or endorsement.

(3) VOCs (Volatile organic compounds) emitted from materials used in the construction of fixtures can penetrate silicone encapsulants of LEDs and discolor when exposed to heat and photonic energy. The result can be a significant loss of light output from the fixture. Knowledge of the properties of the materials selected to be used in the construction of fixtures can help prevent these issues. Refond advises against the use of any chemicals or materials that have been found or are suspected to have an adverse affect on device performance or reliability. To verify compatibility, Refond recommends that all chemicals and materials be tested in the specific application and environment for which they are intended to be used. Attaching LEDs, do not use adhesives that outgas organic vapor.

(4) Handle the component along the side surface by using forceps or appropriate tools; do not directly touch or Handle the silicone lens surface, it may damage the internal circuitry.

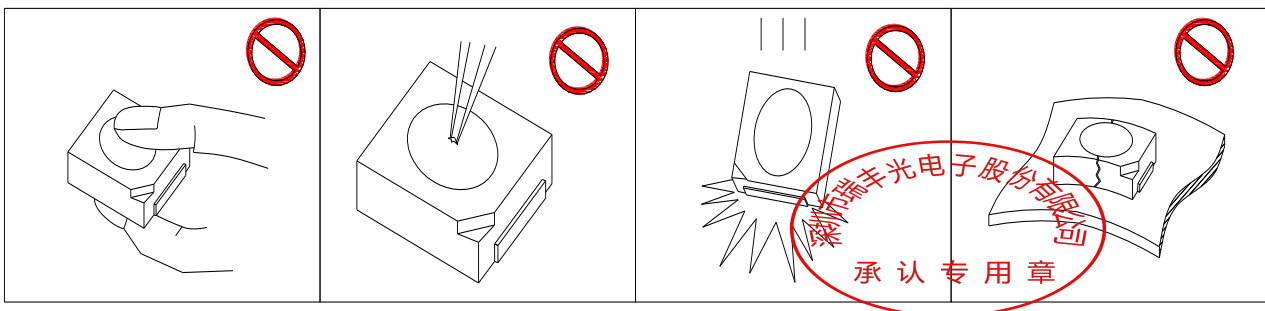

Fig 4-1 Title

(5) In designing a circuit, the current through each LED can not exceed the absolute maximum rating specified for each LED. In the mean while, resistors for protection should be applied, otherwise slight voltage shift will cause big current change, burn out may happen. The driving circuit must be designed to allow forward voltage only when it is ON or OFF. If the reverse voltage is applied to LED, migration can be generated resulting in LED damage. (6) Thermal Design is paramount importance because heat generation may result in the Characteristics decline, such as brightness decreased, Color change and so on. Please consider the heat generation of the LEDs when making the system design.

(7) Compared to standard encapsulants, silicone is generally softer, and the surface is more likely to attract dust , requiring special care during processing. In cases where a minimal level of dirt and dust particles cannot be guaranteed, a suitable cleaning solution must be applied to the surface after the soldering of components. Refond suggests using isopropyl alcohol for cleaning. In case other solvents are used, it must be assured that these solvents do not dissolve the package or resin. Ultrasonic cleaning is not recommended. Ultrasonic cleaning may cause damage to the LED.

Table 4-1Storage

Conditions		Temperature	Humidity	Time
Storage	Before Opening Aluminum Bag	$\leq 30^{\circ}\text{C}$	$\leq 75\%$	Within 1 Year From Date
	After Opening Aluminum Bag	$\leq 30^{\circ}\text{C}$	$\leq 60\%$	24hours
Baking		$60 \pm 5^{\circ}\text{C}$		$\geq 24\text{hours}$

- (8) If the moisture absorbent material (silica gel) has faded away or the LEDs have exceeded the storage time , baking treatment should be performed after unpacking and based on the following condition (65 ± 5) °C for above 24 hours. If the package is flatulence or damaged, please notify the sales staff to assist.
- (9) Similar to most Solid state devices; LEDs are sensitive to Electro-Static Discharge (ESD) and Electrical Over Stress (EOS).
- (10) Other points for attention, please refer to our relevant information.





REFOND

