

RF-RSRL30TS-AB-G

PLCC-4 with Lens 60° Series

Feature

- ◆ MSL:2
- ◆ RoHS compliant
- ◆ 3.50mm×2.80mm×3.25mm
- ◆ The materials of the LED die is AlGaInP
- ◆ Qualifications: The product qualification test plan is based on the guidelines of AEC-Q101 Stress Test Qualification for Automotive Grade Discrete Semiconductors.

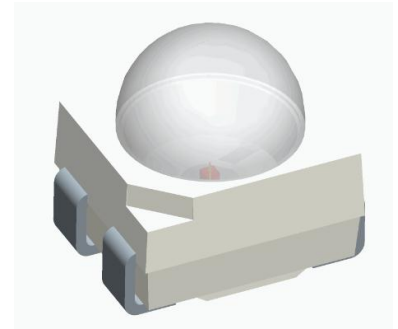

Package Outline

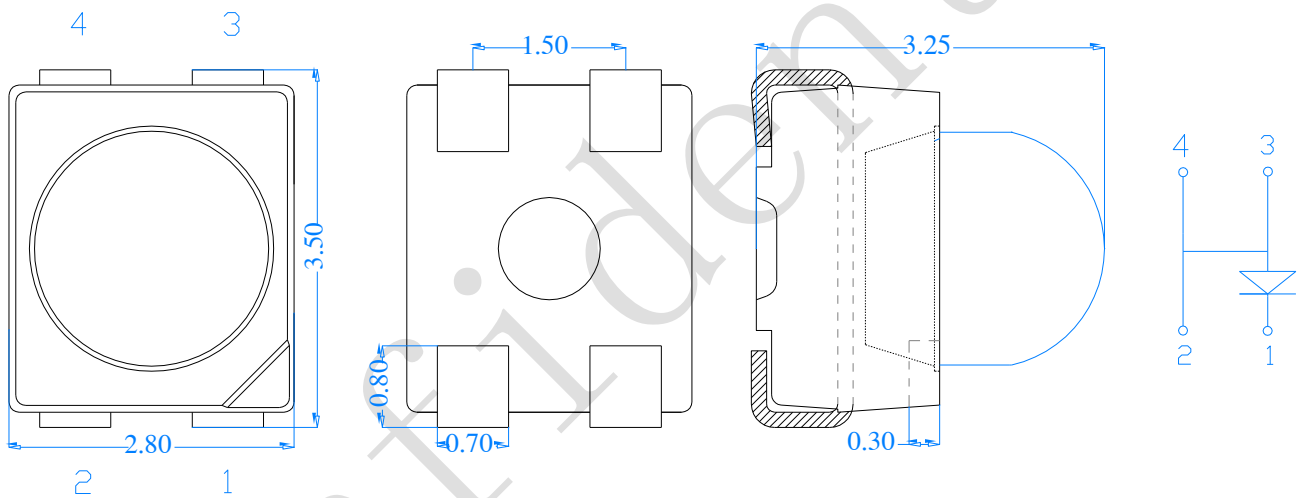



ATTENTION
OBSERVE PRECAUTIONS
FOR HANDLING
ELECTROSTATIC
SENSITIVE DEVICES

NOTES:

1. All dimensions are in millimeters (inches);
2. Tolerances are $\pm 0.2\text{mm}$ (0.008inch) unless otherwise noted.

Absolute maximum ratings at Ts=25°C

Parameter	Symbol	Value	Unit
Forward current	If	70	mA
Reverse voltage	Vr	5	V
Operating temperature range	Top	-40 ~+100	°C
Storage temperature range	Tstg	-40 ~+100	°C
Pulse Forward Current Brilliant	Ifp	100	mA
Electrostatic Discharge	ESD	2000(HBM)	V
Junction temperature	Tj	120	°C
Thermal resistance	Rth J-A	Rth J-S	130

Electro-optical characteristics at Ts=25°C

Parameter	Test Condition	Symbol	Value			Unit
			Min.	Typ.	Max.	
Forward voltage	If=50mA	Vf	2.0	--	2.1	V
			2.1	--	2.2	
			2.2	--	2.3	
			2.3	--	2.4	
			2.4	--	2.5	
			2.5	--	2.6	
			2.6	--	2.7	
			2.7	--	2.8	
Luminous intensity	If=50mA	Iv	3500	--	4300	mcd
			4300	--	5300	
			5300	--	6500	
Dominant wavelength	If=50mA	Wd	627.5	--	630.0	nm
			630.0	--	632.5	
			632.5	--	635.0	
Viewing angle at 50% Iv	If=50mA	2 θ 1/2	--	60	--	Deg

NOTE: (Tolerance: Iv ±10%, λ_d ±2nm, Vf ±0.05V, X, Y ±0.005)

IFP Conditions: Pulse Width ≤ 10msec. and Duty ≤ 1/10.

Typical optical characteristics curves

Fig.1 Maximum Forward Current vs. Ambient Temperature

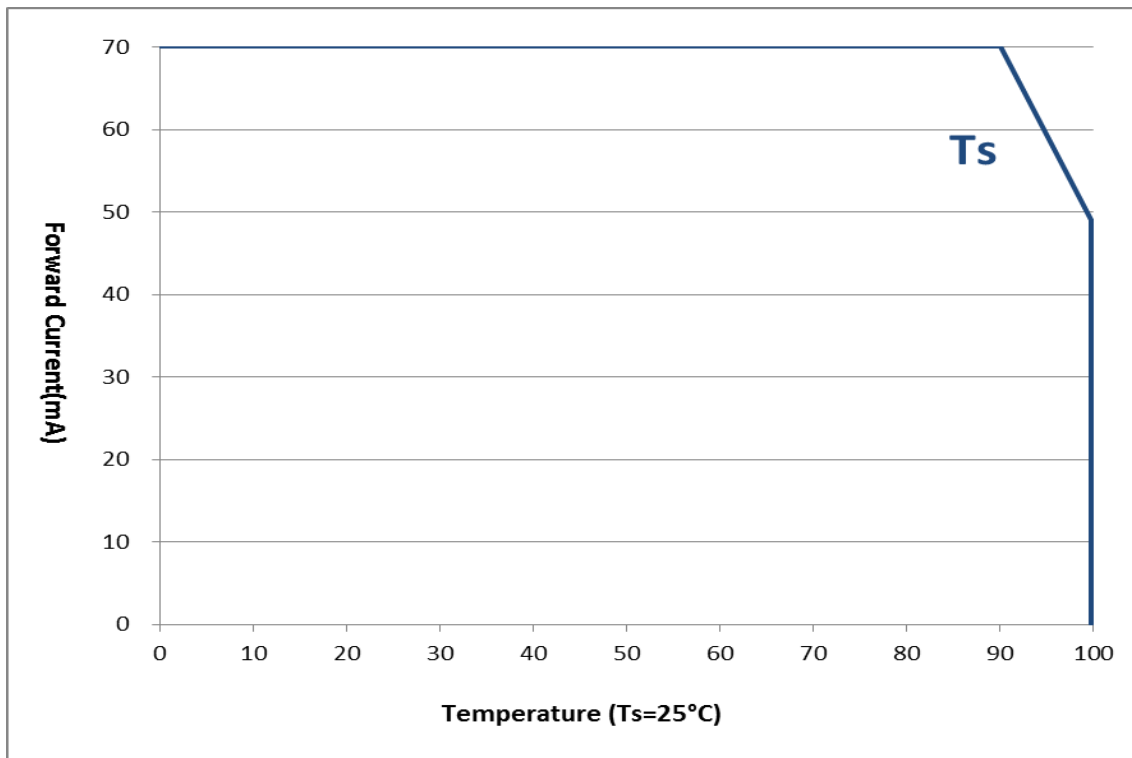

Fig.2 Relative Intensity vs. Forward Current (Ts=25°C)

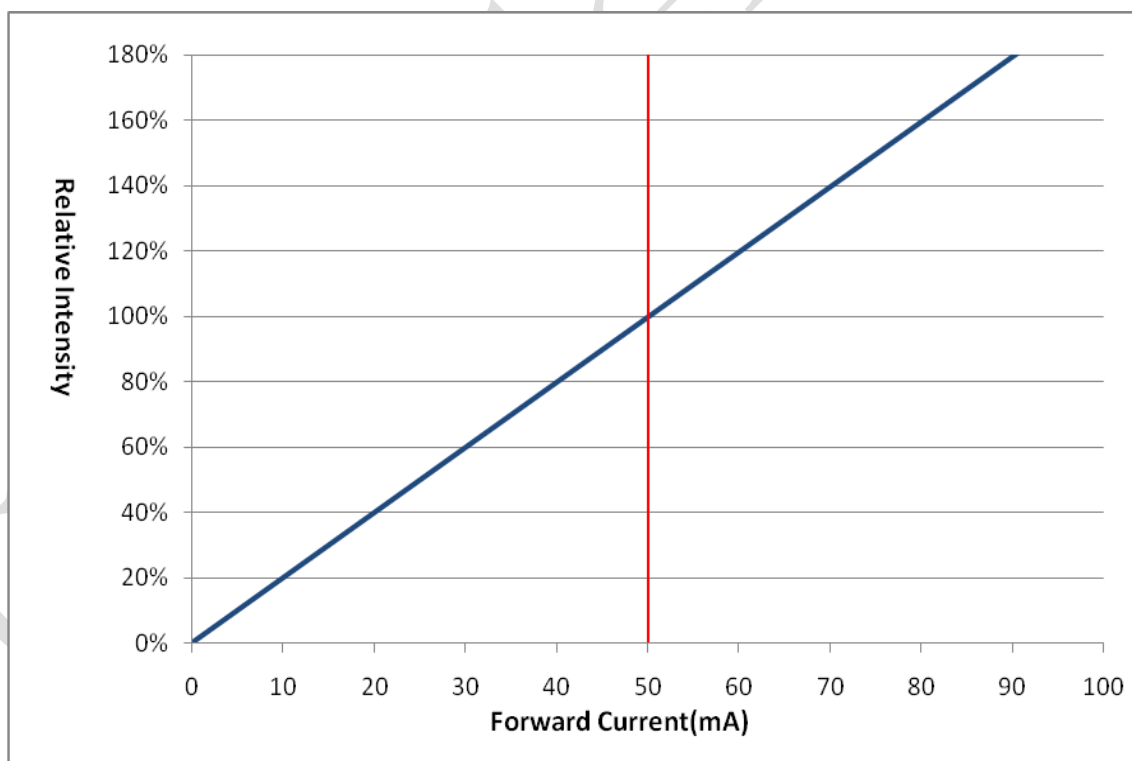

Fig.3 Forward Current vs. Forward Voltage (Ts=25°C)

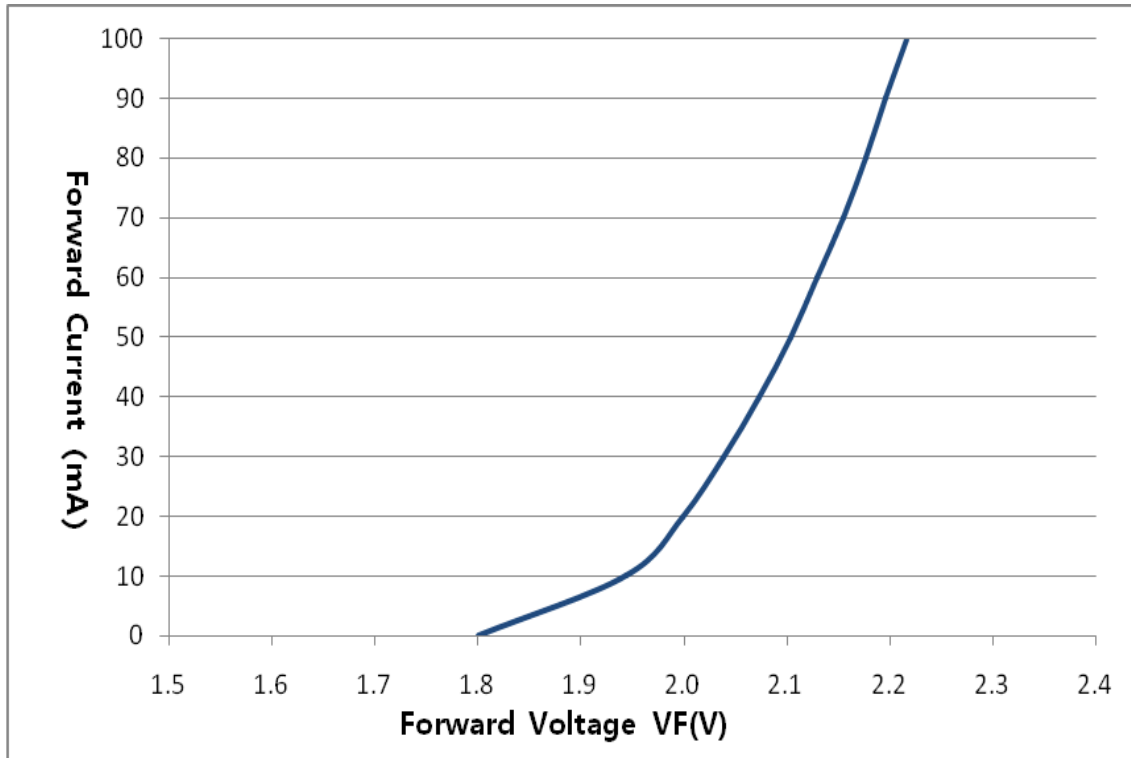

Fig.4 Forward current vs. Dominate wavelength (Ts=25°C)

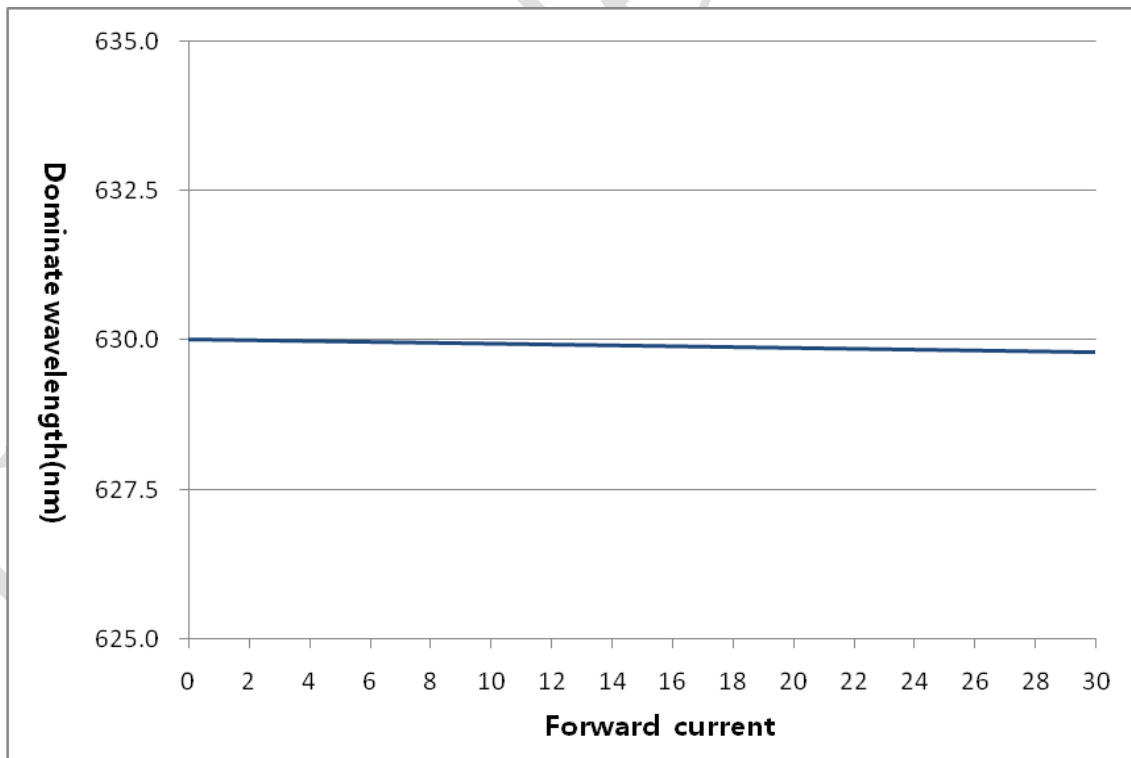

Fig.5 Relative Intensity vs. Wavelength (Ts=25°C)

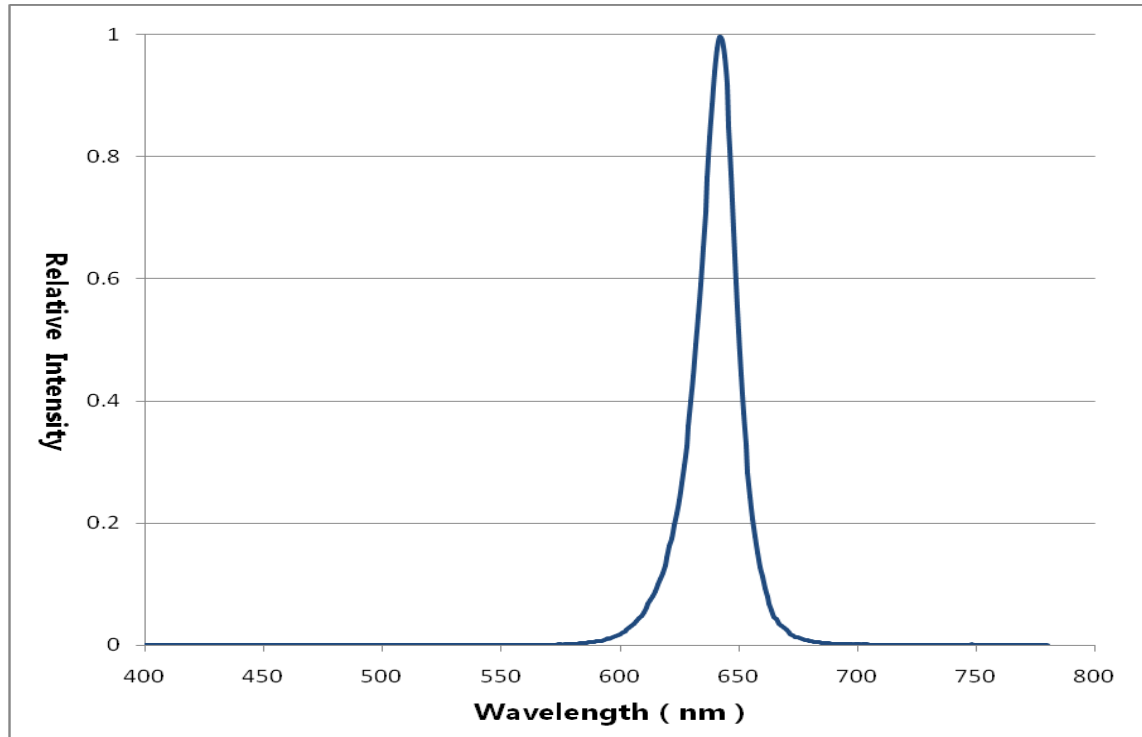
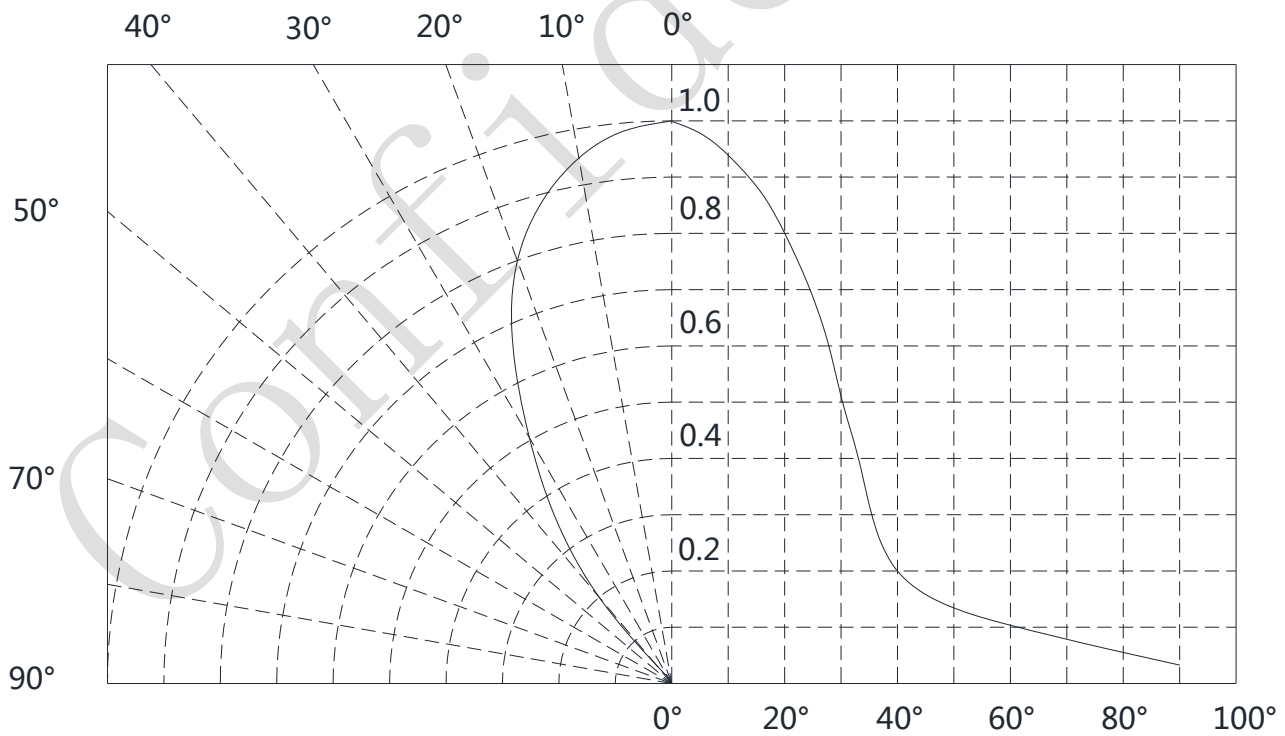
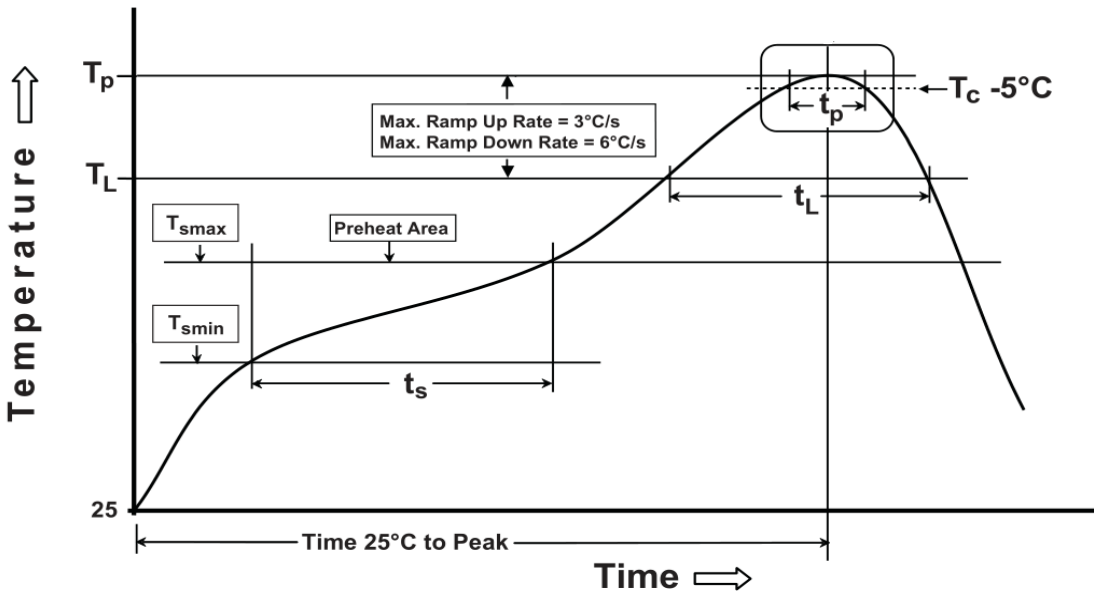

Fig.6 Diagram characteristics of radiation



Reference Soldering Conditions

- Maximum Body Case Temperature Profile for evaluation of Reflow Profile.



Note:

Preheat

Temperature min (T _{smin})	150 °C
Temperature max (T _{smax})	200°C
Time (T _{smin} to T _{smax}) (t _s)	60-120 seconds
Average ramp-up rate (T _{smax} to T _p)	3 °C/second max.
Other	
Liquidus Temperature (T _L)	217 °C
Time above liquidus Temperature (t _L)	60-150sec
Peak Temperature(T _p)	260°C
Time within 5°C of Actual Peak Temperature: T _p -5°C	30s
Ramp-Down Rate form Peak Temperature	6°C/second max.
Time 25°C to Peak Temperature	8 minutes max.
Reflow times	3 times

All parameters are maximum body case temperature values and cannot be considered as a soldering profile. The body case temperature was measured by soldering a thermal couple to the soldering point of LEDs.

RECOMMEND PAD DESIGN (Units: mm)

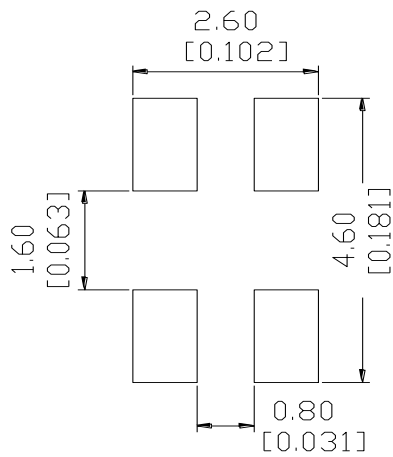

■ Soldering iron

1. When hand soldering, keep the temperature of the iron under 300°C, and at that temperature keep the time under 3 sec.
2. The hand soldering should be done only a time
3. The basic spec is ≤ 5 sec. when the temperature of 260°C, do not contact the resin when hand soldering

■ Rework

1. Customer must finish rework within 5 sec under 260°C
2. The head of iron can not touch the resin
3. Twin-head type is preferred.

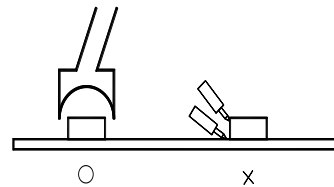

Reliability

(1)TEST ITEMS AND RESULTS

Test Item	Ref. Standard	Test Conditions	Note	Number of Damaged
High Temperature Storage	JEITA ED-4701200 201/AEC-Q101	100°C	1000hr.	0/22
Low Temperature Storage	JEITA ED-4701200 202/AEC-Q101	-40°C	1000hr.	0/22
Temp.Humidity Storage	JEITA ED-4701 100 103/ AEC-Q101	60°C/90%RH	1000hr.	0/22
Steady State Operating Life	EIA/JESD 22-A108-B/AEC-Q101	25°C/50mA	1000 hr.	0/22
High Temperature Operating Life	EIA/JESD 22-A108B/AEC-Q101	85°C/50mA	1000 hr.	0/22
Low Temperature Operating Life	EIA/JESD 22-A108B/AEC-Q101	-40°C/50mA	1000 hr.	0/22
Steady State Operating life of High Humidity Heat	JEITA ED-4701 100 102/AEC-Q101	85°C/85%HR/50mA	1000 hr.	0/22
Temperature Cycle	JEITA ED-4701 100 105	-40°C 30min ↑↓5min 100°C 30min	1000 hr.	0/22
ElectroStatic Discharge	EIA/JESD 22A114-A:Class 2/AEC-Q101	HBM:100Pf/1.5Kohm 2KV	3times	0/22

(2)CRITERIA FOR JUDGING THE DAMAGE

Item	Symbol	Test Conditions	Criteria for Judgement	
			Min.	Max.
Forward Voltage	VF	IF=50mA	—	U.S.L*)×1.1
Reverse Current	IR	VR=5V	—	U.S.L*)×2.0
Luminous Intensity	IV	IF=50mA	L.S.L**)×0.7	—

U.S.L.: Upper Standard Level

L.S.L.: Lower Standard Level

Handling of Silicone Resin LEDS.

LED operating environment and sulfur element composition cannot be over 100PPM in the LED mating usage material. This is provided for informational purposes only and is not a warranty or endorsement LED.

In order to prevent external material from getting into the inside of LED, which may damage the LEDs. the single content of Bromine element requires less than 900PPM, the single content of Chlorine element requires less than 900PPM, the total content of Bromine element and Chlorine element in the external materials of the application products requires less than 1500PPM. This is provided for informational purposes only and is not a warranty or endorsement.

- Compared with silicone epoxy is hard and brittle, but silicone is soft and well bent. These attributes, but greatly reduces the thermal shock, on the other hand, external shocks impact is greater than the epoxy. Therefore require special attention to the following when handling the LED of silicon Encap.
- Processing, mechanical stress on the surface of the product must be minimized.
- Please refrain from pressing the encapsulant products of your hand.
- Shaped objects, such as tweezers or a pincette, please avoid contact with the encapsulant.
- Pick-up nozzle, please do not contact with the directly encapsulant in SMT process.
- Please do not from building a laminated substrate completed the SMT.

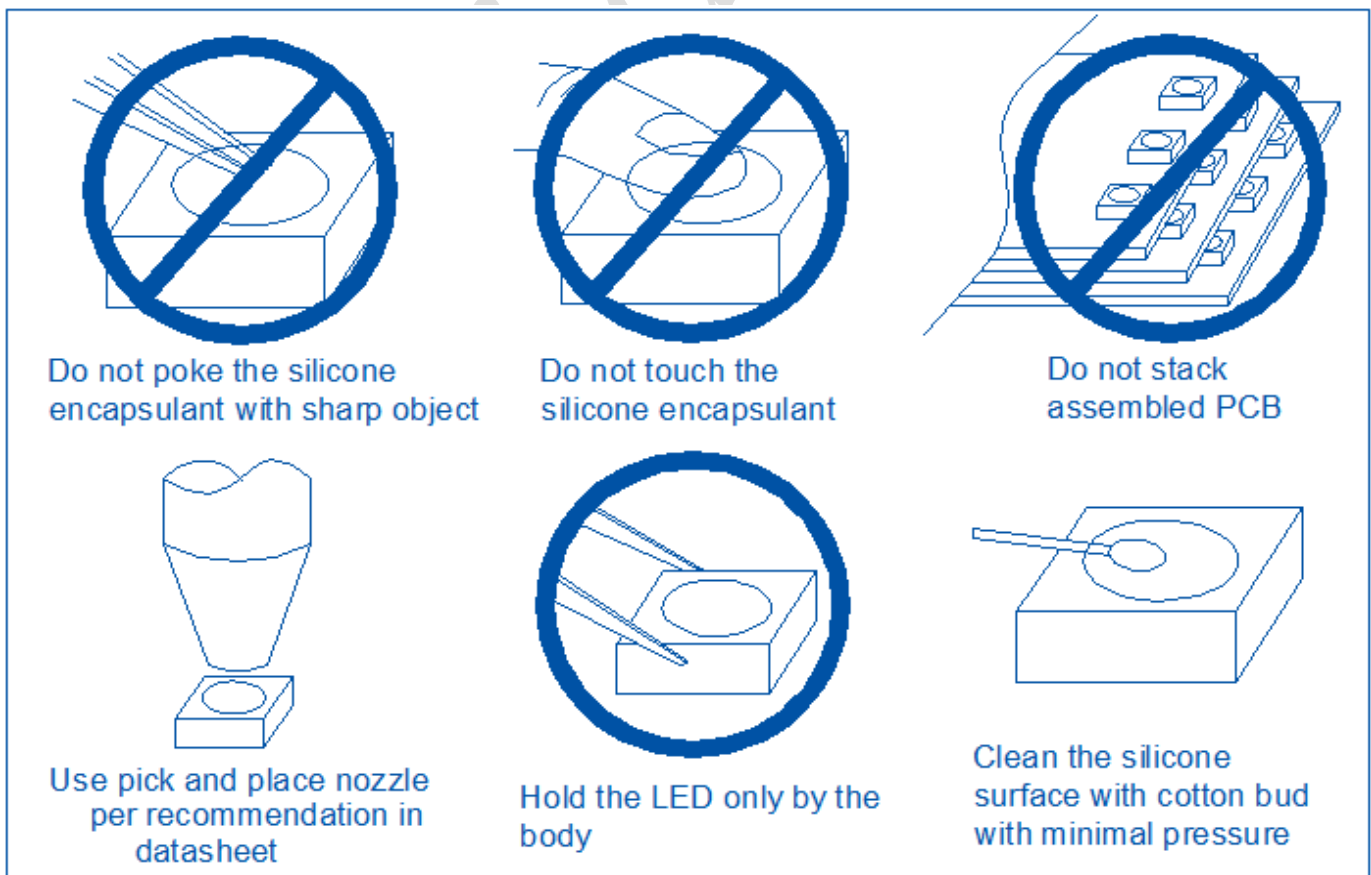

Packaging Specifications

• Dimensions of Tape (Unit: mm)

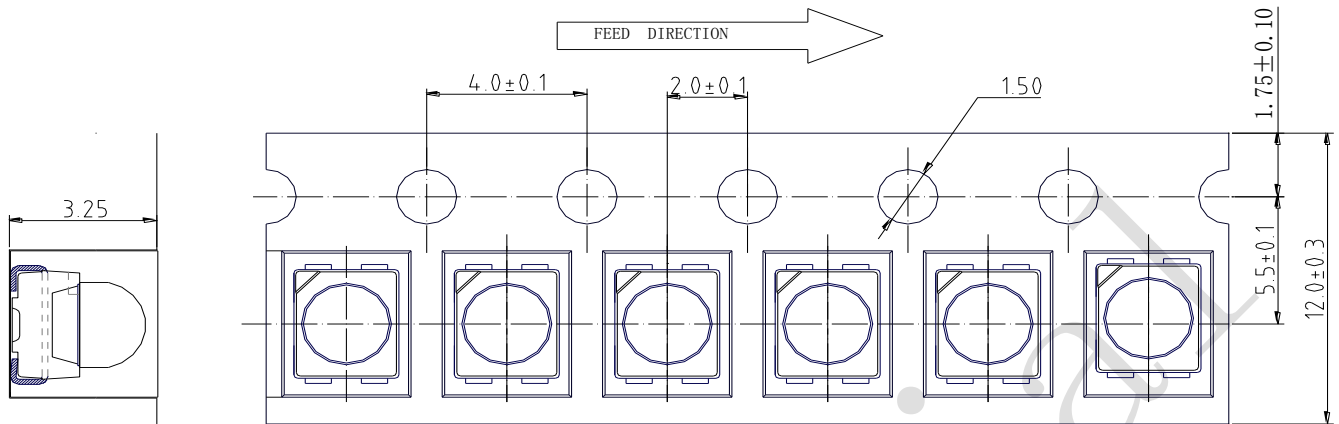

• Feeding Direction

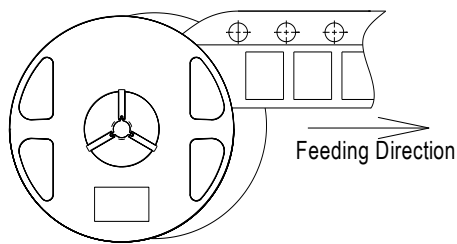

• Dimensions of Reel (Unit: mm)

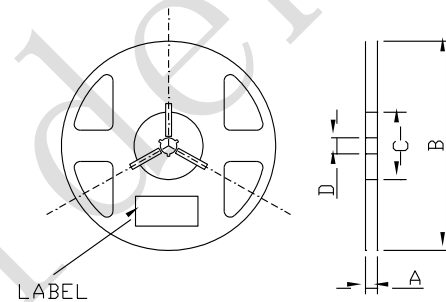

A	12 ± 1mm
B	330 ± 2mm
C	100 ± 1mm
D	13.0 ± 0.2mm

NOTES

1. Empty component pockets are sealed with top cover tape;
2. The maximum number of missing lamps is two;
3. The cathode is oriented towards the tape sprocket hole in accordance with ANSI/EIA RS-481 specifications.
4. 2000 pcs/ Reel.

Revision History:

Rev.	Modified date	File modified contents
0	2017/07/12	New Spec
1	2017/11/30	Controlled encoding increases the patent suffix
2	2018/02/03	Electrical parameter modification.

Confidential