

High voltage high/low-side driver

Datasheet - production data

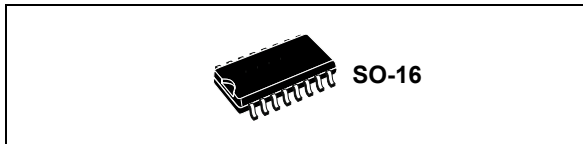

Features

- High voltage rail up to 600 V
- dV/dt immunity ± 50 V/nsec in full temperature range
- Driver current capability: 290 mA source, 430 mA sink
- Switching times 75/35 nsec rise/fall with 1 nF load
- 3.3 V, 5 V TTL/CMOS inputs with hysteresis
- Integrated bootstrap diode
- Operational amplifier for advanced current sensing
- Comparator for fast fault protection
- Smart shutdown function
- Adjustable deadtime
- Interlocking function
- Compact and simplified layout
- Bill of material reduction

Applications

- Home appliances
- Motor drivers
 - DC, AC, PMDC and PMAC motors
 - FOC and sensorless BEMF detection systems
- Industrial applications and drives
- Induction heating
- HVAC
- Factory automation
- Power supply systems

Description

The L6390 is a full featured high voltage device manufactured with the BCD™ “offline” technology. It is a single-chip half-bridge gate driver for N-channel power MOSFETs or IGBTs. The high-side (floating) section is able to work with voltage rail up to 600 V.

Both device outputs can sink and source 430 mA and 290 mA respectively. Prevention from cross conduction is ensured by interlocking and programmable deadtime functions.

The device has dedicated input pins for each output and a shutdown pin. The logic inputs are CMOS/TTL compatible down to 3.3 V for easy interfacing with control devices. Matched delays between low-side and high-side sections guarantee no cycle distortion and allow high frequency operation.

The L6390 embeds an operational amplifier suitable for advanced current sensing in applications such as field oriented motor control or for sensorless BEMF detection. A comparator featuring advanced smartSD function is also integrated in the device, ensuring fast and effective protection against fault events like overcurrent, overtemperature, etc.

The L6390 device features also UVLO protection on both the lower and upper driving sections, preventing the power switches from operating in low efficiency or dangerous conditions.

The integrated bootstrap diode as well as all of the integrated features of this IC make the application PCB design easier, more compact and simple thus reducing the overall bill of material.

The device is available in an SO-16 tube and tape and reel packaging options.

Contents

1	Block diagram	3
2	Pin connection	4
3	Electrical data	5
3.1	Absolute maximum ratings	5
3.2	Thermal data	5
3.3	Recommended operating conditions	6
4	Electrical characteristics	7
4.1	AC operation	7
4.2	DC operation	9
5	Timing and waveforms definitions	12
6	Input logic	14
7	Smart shutdown function	15
8	Typical application diagram	18
9	Bootstrap driver	19
	C _{BOOT} selection and charging	19
10	Package information	21
10.1	SO-16 package information	21
11	Order codes	23
12	Revision history	24

1 Block diagram

Figure 1. Block diagram

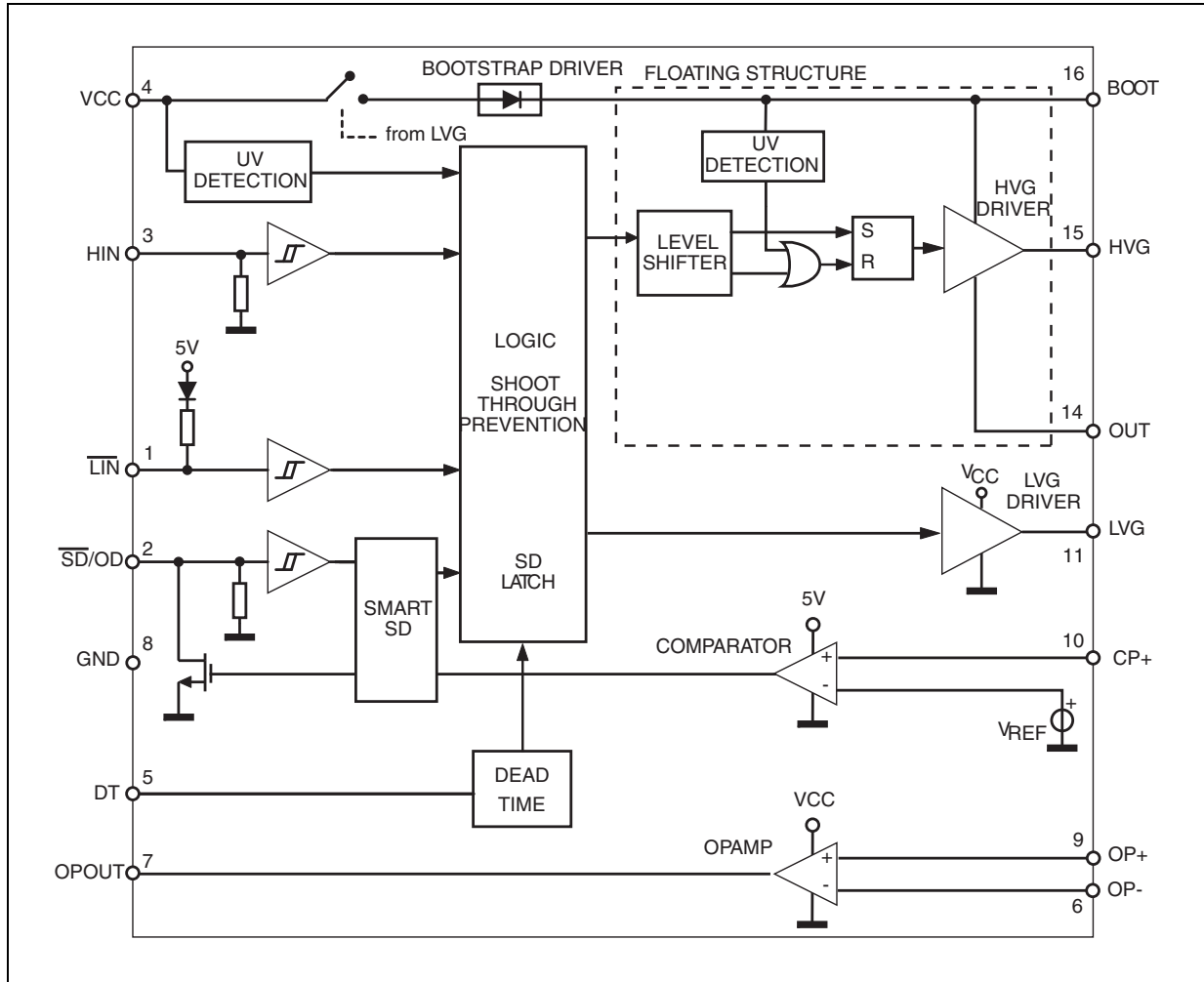

2 Pin connection

Figure 2. Pin connection (top view)

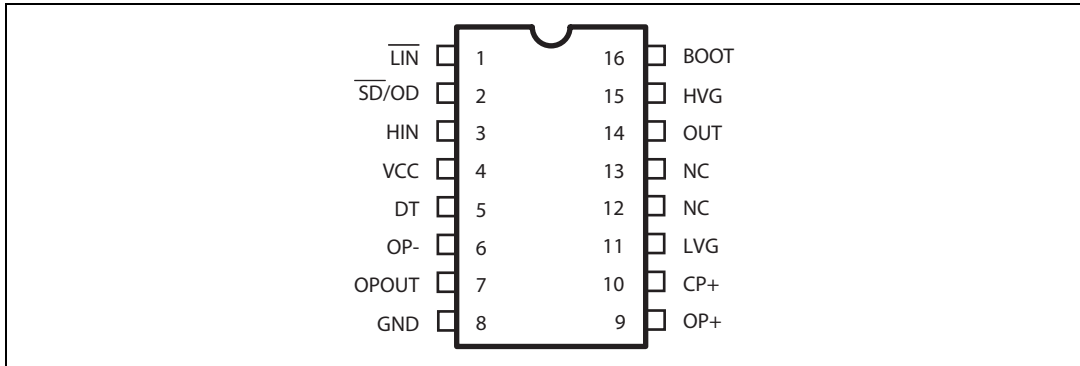

Table 1. Pin description

Pin no.	Pin name	Type	Function
1	LIN	I	Low-side driver logic input (active low)
2	SD/OD ⁽¹⁾	I/O	Shutdown logic input (active low)/open drain (comparator output)
3	HIN	I	High-side driver logic input (active high)
4	VCC	P	Lower section supply voltage
5	DT	I	Deadtime setting
6	OP-	I	Op amp inverting input
7	OPOUT	O	Op amp output
8	GND	P	Ground
9	OP+	I	Op amp non-inverting input
10	CP+	I	Comparator input
11	LVG ⁽¹⁾	O	Low-side driver output
12, 13	NC		Not connected
14	OUT	P	High-side (floating) common voltage
15	HVG ⁽¹⁾	O	High-side driver output
16	BOOT	P	Bootstrap supply voltage

1. The circuit provides less than 1 V on the LVG and HVG pins (at I_{sink} = 10 mA), with V_{CC} > 3 V. This allows the omission of the “bleeder” resistor connected between the gate and the source of the external MOSFET normally used to hold the pin low; the gate driver assures low impedance also in SD condition.

3 Electrical data

3.1 Absolute maximum ratings

Table 2. Absolute maximum ratings

Symbol	Parameter	Value		Unit
		Min.	Max.	
V_{CC}	Supply voltage	- 0.3	21	V
V_{OUT}	Output voltage	$V_{BOOT} - 21$	$V_{BOOT} + 0.3$	V
V_{BOOT}	Bootstrap voltage	- 0.3	620	V
V_{hvg}	High-side gate output voltage	$V_{OUT} - 0.3$	$V_{BOOT} + 0.3$	V
V_{lvg}	Low-side gate output voltage	- 0.3	$V_{CC} + 0.3$	V
V_{OP+}	Op amp non-inverting input	- 0.3	$V_{CC} + 0.3$	V
V_{OP-}	Op amp inverting input	- 0.3	$V_{CC} + 0.3$	V
V_{CP+}	Comparator input voltage	- 0.3	$V_{CC} + 0.3$	V
V_i	Logic input voltage	- 0.3	15	V
V_{od}	Open drain voltage	- 0.3	15	V
dV_{out}/dt	Allowed output slew rate	-	50	V/ns
P_{tot}	Total power dissipation ($T_A = 25\text{ °C}$)	-	800	mW
T_J	Junction temperature	-	150	°C
T_{stg}	Storage temperature	-50	150	°C
ESD	Human body model	2		kV

3.2 Thermal data

Table 3. Thermal data

Symbol	Parameter	SO-16	Unit
$R_{th(JA)}$	Thermal resistance junction to ambient	120	°C/W

3.3 Recommended operating conditions

Table 4. Recommended operating conditions

Symbol	Pin	Parameter	Test condition	Min.	Max.	Unit
V_{CC}	4	Supply voltage	-	12.5	20	V
$V_{BO}^{(1)}$	16 - 14	Floating supply voltage	-	12.4	20	V
V_{OUT}	14	DC output voltage	-	- 9 ⁽²⁾	580	V
f_{sw}	-	Switching frequency	HVG, LVG load $C_L = 1$ nF	-	800	kHz
T_J	-	Junction temperature	-	-40	125	°C

1. $V_{BO} = V_{BOOT} - V_{OUT}$.

2. LVG off. $V_{CC} = 12.5$ V. Logic is operational if $V_{BOOT} > 5$ V. Refer to the AN2738 for more details.

4 Electrical characteristics

4.1 AC operation

Table 5. AC operation electrical characteristics ($V_{CC} = 15\text{ V}$; $T_J = +25\text{ °C}$)

Symbol	Pin	Parameter	Test condition	Min.	Typ.	Max.	Unit
t_{on}	1 vs. 11	High/low-side driver turn-on propagation delay	$V_{OUT} = 0\text{ V}$ $V_{BOOT} = V_{CC}$ $C_L = 1\text{ nF}$ $V_i = 0\text{ to }3.3\text{ V}$ See Figure 4 on page 12	50	125	200	ns
t_{off}	3 vs. 15	High/low-side driver turn-off propagation delay		50	125	200	ns
t_{sd}	2 vs. 11, 15	Shutdown to high/low-side driver propagation delay		50	125	200	ns
t_{isd}	-	Comparator triggering to high/low-side driver turn-off propagation delay	Measured applying a voltage step from 0 V to 3.3 V to pin CP+.	50	200	250	ns
MT	-	Delay matching, HS and LS turn-on/off	-	-	30	ns	
DT	5	Deadtime setting range ⁽¹⁾	$R_{DT} = 0$	0.1	0.18	0.25	μs
			$R_{DT} = 37\text{ k}\Omega$, $C_L = 1\text{ nF}$, $C_{DT} = 100\text{ nF}$	0.48	0.6	0.72	μs
			$R_{DT} = 136\text{ k}\Omega$, $C_L = 1\text{ nF}$, $C_{DT} = 100\text{ nF}$	1.35	1.6	1.85	μs
			$R_{DT} = 260\text{ k}\Omega$, $C_L = 1\text{ nF}$, $C_{DT} = 100\text{ nF}$	2.6	3.0	3.4	μs
MDT	-	Matching deadtime ⁽²⁾	$R_{DT} = 0$	-	-	80	ns
			$R_{DT} = 37\text{ k}\Omega$, $C_L = 1\text{ nF}$, $C_{DT} = 100\text{ nF}$	-	-	120	ns
			$R_{DT} = 136\text{ k}\Omega$, $C_L = 1\text{ nF}$, $C_{DT} = 100\text{ nF}$	-	-	250	ns
			$R_{DT} = 260\text{ k}\Omega$, $C_L = 1\text{ nF}$, $C_{DT} = 100\text{ nF}$	-	-	400	ns
t_r	11, 15	Rise time	$C_L = 1\text{ nF}$	-	75	120	ns
t_f		Fall time	$C_L = 1\text{ nF}$	-	35	70	ns

1. See [Figure 3](#).

2. $MDT = |DT_{LH} - DT_{HL}|$ see [Figure 6 on page 13](#).

Figure 3. Typical deadtime vs. DT resistor value

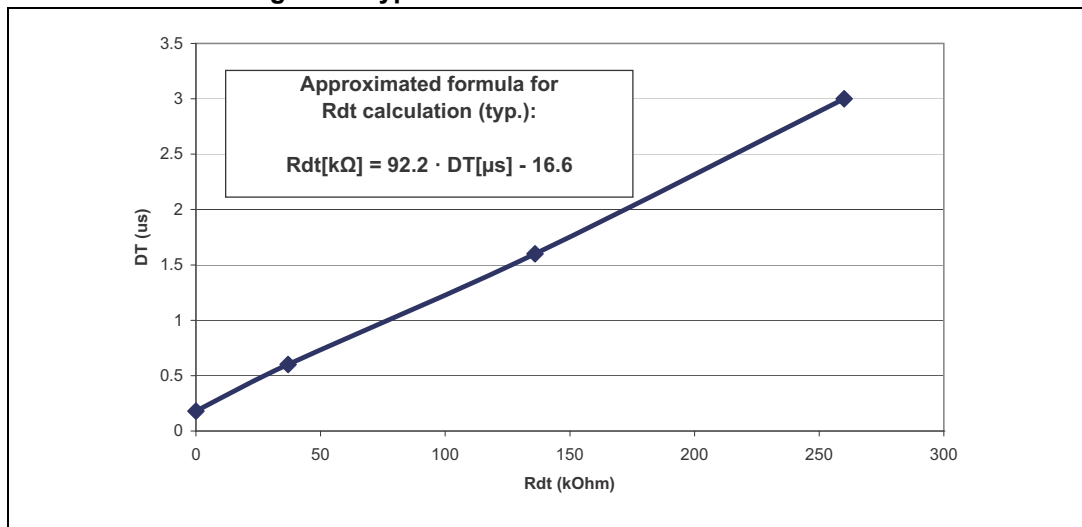

4.2 DC operation

Table 6. DC operation electrical characteristics ($V_{CC} = 15\text{ V}$; $T_J = +25\text{ }^\circ\text{C}$)

Symbol	Pin	Parameter	Test condition	Min.	Typ.	Max.	Unit
Low supply voltage section							
V_{CC_hys}	4	V_{CC} UV hysteresis	-	1200	1500	1800	mV
V_{CC_thON}		V_{CC} UV turn-ON threshold	-	11.5	12	12.5	V
V_{CC_thOFF}		V_{CC} UV turn-OFF threshold	-	10	10.5	11	V
I_{QCCU}		Undervoltage quiescent supply current	$V_{CC} = 10\text{ V}$ $\overline{SD} = 5\text{ V}$; $\overline{LIN} = 5\text{ V}$; $HIN = GND$; $R_{DT} = 0\ \Omega$; $CP+ = OP+ = GND$; $OP- = 5\text{ V}$	90	120	150	μA
I_{QCC}		Quiescent current	$V_{CC} = 15\text{ V}$ $\overline{SD} = 5\text{ V}$; $\overline{LIN} = 5\text{ V}$; $HIN = GND$; $R_{DT} = 0\ \Omega$; $CP+ = OP+ = GND$; $OP- = 5\text{ V}$	300	720	1000	μA
V_{ref}	-	Internal reference voltage	-	500	540	580	mV
Bootstrapped supply voltage section⁽¹⁾							
V_{BO_hys}	16	V_{BO} UV hysteresis	-	1200	1500	1800	mV
V_{BO_thON}		V_{BO} UV turn-ON threshold	-	11.1	11.5	12.1	V
V_{BO_thOFF}		V_{BO} UV turn-OFF threshold	-	9.8	10	10.6	V
I_{QBOU}		Undervoltage V_{BO} quiescent current	$V_{BO} = 9\text{ V}$ $\overline{SD} = 5\text{ V}$; \overline{LIN} and $HIN = 5\text{ V}$; $R_{DT} = 0\ \Omega$; $CP+ = OP+ = GND$; $OP- = 5\text{ V}$	30	70	110	μA
I_{QBO}		V_{BO} quiescent current	$V_{BO} = 15\text{ V}$ $\overline{SD} = 5\text{ V}$; \overline{LIN} and $HIN = 5\text{ V}$; $R_{DT} = 0\ \Omega$; $CP+ = OP+ = GND$; $OP- = 5\text{ V}$	30	150	240	μA
I_{LK}	-	High voltage leakage current	$V_{hvg} = V_{OUT} = V_{BOOT} = 600\text{ V}$	-	-	10	μA
$R_{DS(on)}$	-	Bootstrap driver on-resistance ⁽²⁾	LVG ON	-	120	-	Ω

Table 6. DC operation electrical characteristics (V_{CC} = 15 V; T_J = + 25 °C) (continued)

Symbol	Pin	Parameter	Test condition	Min.	Typ.	Max.	Unit
Driving buffers section							
I _{so}	11, 15	High/low-side source short-circuit current	V _{IN} = V _{ih} (t _p < 10 μs)	200	290	-	mA
I _{si}		High/low-side sink short-circuit current	V _{IN} = V _{il} (t _p < 10 μs)	250	430	-	mA
Logic inputs							
V _{il}	1, 2, 3	Low level logic threshold voltage	-	0.8	-	1.1	V
V _{ih}		High level logic threshold voltage	-	1.9	-	2.25	V
V _{il_S}	1, 3	Single input voltage	$\overline{\text{LIN}}$ and HIN connected together and floating	-	-	0.8	V
I _{HINh}	3	HIN logic "1" input bias current	HIN = 15 V	110	175	260	μA
I _{HINl}		HIN logic "0" input bias current	HIN = 0 V	-	-	1	μA
I _{LINl}	1	$\overline{\text{LIN}}$ logic "0" input bias current	$\overline{\text{LIN}}$ = 0 V	3	6	20	μA
I _{LINh}		$\overline{\text{LIN}}$ logic "1" input bias current	$\overline{\text{LIN}}$ = 15 V	-	-	1	μA
I _{SDh}	2	$\overline{\text{SD}}$ logic "1" input bias current	$\overline{\text{SD}}$ = 15 V	10	40	100	μA
I _{SDl}		$\overline{\text{SD}}$ logic "0" input bias current	$\overline{\text{SD}}$ = 0 V	-	-	1	μA
R _{PD_SD}	2	$\overline{\text{SD}}$ input pull-down resistor	$\overline{\text{SD}}$ = 15 V	150	375	1500	kΩ

1. V_{BO} = V_{BOOT} - V_{OUT}.

2. R_{DSON} is tested in the following way: R_{DSON} = [(V_{CC} - V_{BOOT1}) - (V_{CC} - V_{BOOT2})] / [I₁(V_{CC}, V_{BOOT1}) - I₂(V_{CC}, V_{BOOT2})] where I₁ is the pin 16 current when V_{BOOT} = V_{BOOT1}, I₂ when V_{BOOT} = V_{BOOT2}.

Table 7. Op amp characteristics⁽¹⁾ ($V_{CC} = 15\text{ V}$, $T_J = +25\text{ °C}$)

Symbol	Pin	Parameter	Test condition	Min.	Typ.	Max.	Unit
V_{io}	6, 9	Input offset voltage	$V_{ic} = 0\text{ V}$, $V_o = 7.5\text{ V}$	-	-	6	mV
I_{io}		Input offset current	$V_{ic} = 0\text{ V}$, $V_o = 7.5\text{ V}$	-	4	40	nA
I_{ib}		Input bias current ⁽²⁾		-	100	200	nA
V_{icm}		Input common mode voltage range	-	0	-	$V_{CC}-4$	V
V_{OPOUT}	7	Output voltage swing	OPOUT = OP-; no load	0.07	-	$V_{CC}-4$	V
I_o		Output short-circuit current	Source, $V_{id} = +1$; $V_o = 0\text{ V}$	16	30	-	mA
			Sink, $V_{id} = -1$; $V_o = V_{CC}$	50	80	-	mA
SR	-	Slew rate	$V_i = 1 \div 4\text{ V}$; $C_L = 100\text{ pF}$; unity gain	2.5	3.8	-	V/ μ s
GBWP	-	Gain bandwidth product	$V_o = 7.5\text{ V}$	8	12	-	MHz
A_{vd}	-	Large signal voltage gain	$R_L = 2\text{ k}\Omega$	70	85	-	dB
SVR	-	Supply voltage rejection ratio	vs. V_{CC}	60	75	-	dB
CMRR	-	Common mode rejection ratio	-	55	70	-	dB

1. The operational amplifier is disabled when V_{CC} is in UVLO condition.

2. The direction of the input current is out of the IC.

Table 8. Sense comparator characteristics⁽¹⁾ ($V_{CC} = 15\text{ V}$, $T_J = +25\text{ °C}$)

Symbol	Pin	Parameter	Test condition	Min.	Typ.	Max.	Unit
I_{ib}	10	Input bias current	$V_{CP+} = 1\text{ V}$	-	-	1	μ A
V_{OL}	2	Open drain low level output voltage	$I_{OD} = -3\text{ mA}$	-	-	0.5	V
R_{ON_OD}	2	Open drain ON resistor	-	-	125	167	$\text{k}\Omega$
t_{d_comp}	-	Comparator delay	\overline{SD}/OD pulled to 5 V through 100 $\text{k}\Omega$ resistor	-	90	130	ns
SR	2	Slew rate	$C_L = 180\text{ pF}$; $R_{pu} = 5\text{ k}\Omega$	-	60	-	V/ μ s

1. The comparator is disabled when V_{CC} is in UVLO condition.

5 Timing and waveforms definitions

Figure 4. Propagation delay timing definition

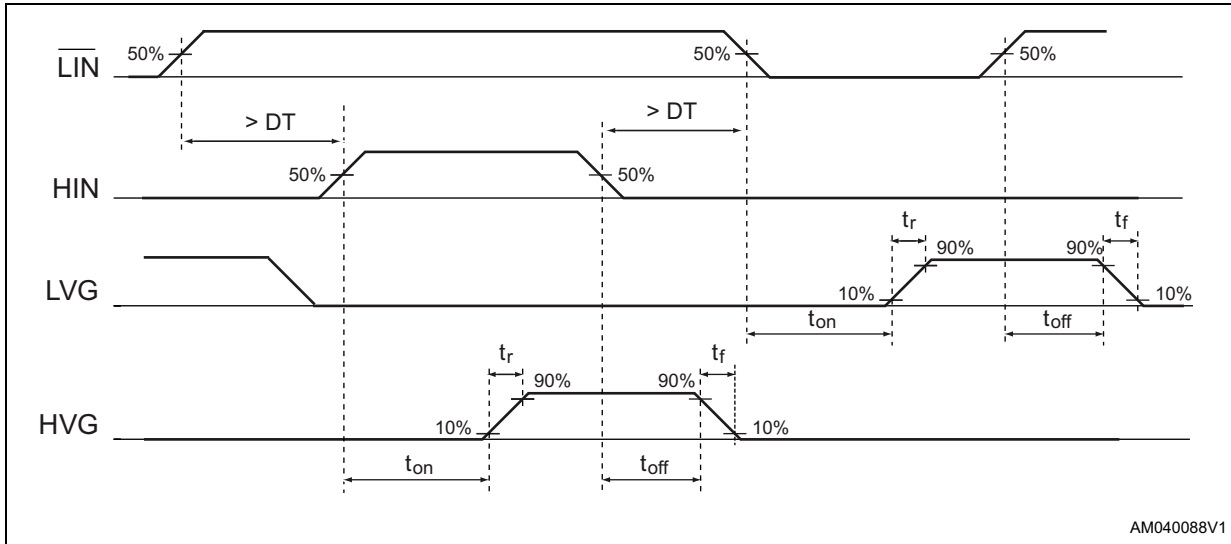

Figure 5. Dead time and interlocking timing definitions

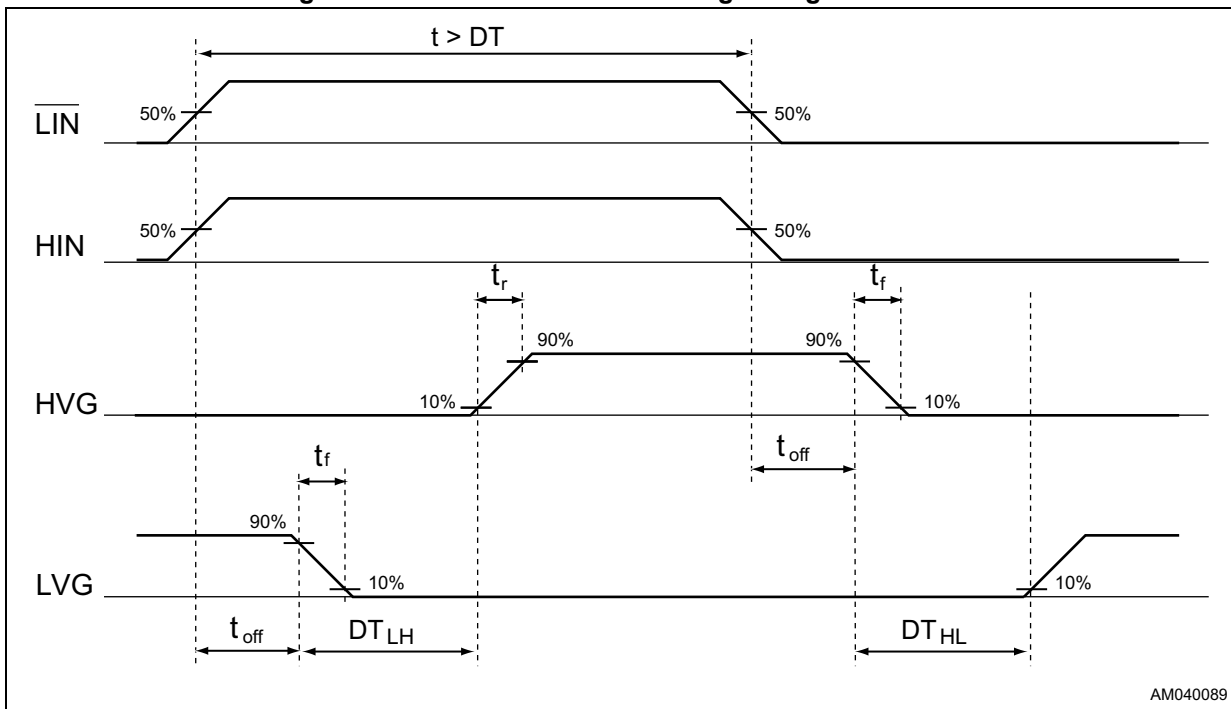
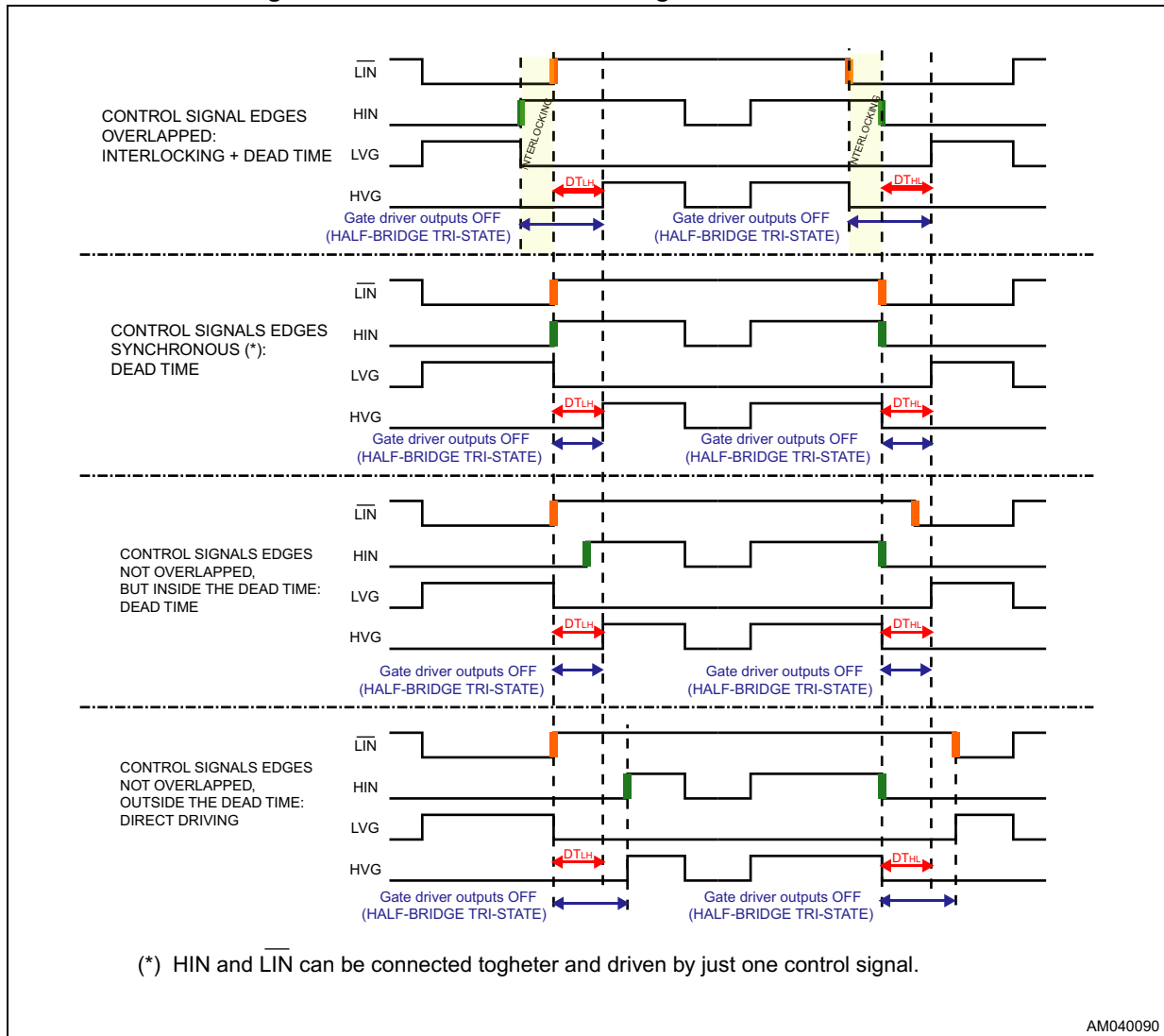

Figure 6. Deadtime and interlocking waveforms definition



6 Input logic

Input logic is provided with an interlocking circuitry which avoids the two outputs (LVG, HVG) being active at the same time when both the logic input pins ($\overline{\text{LIN}}$, HIN) are at a high logic level. In addition, to prevent cross conduction of the external MOSFETs, after each output is turned off, the other output cannot be turned on before a certain amount of time (DT) (see [Figure 5: Dead time and interlocking timing definitions](#)).

Table 9. Truth table

Input			Output	
$\overline{\text{SD}}$	$\overline{\text{LIN}}$	HIN	LVG	HVG
L	X ⁽¹⁾	X ⁽¹⁾	L	L
H	H	L	L	L
H	L	H	L	L
H	L	L	H	L
H	H	H	L	H

1. X: don't care.

7 Smart shutdown function

The L6390 device integrates a comparator committed to the fault sensing function. The comparator has an internal voltage reference V_{ref} connected to the inverting input, while the non-inverting input is available on the pin 10. The comparator input can be connected to an external shunt resistor in order to implement a simple overcurrent detection function. The output signal of the comparator is fed to an integrated MOSFET with the open drain output available on the pin 2, shared with the \overline{SD} input. When the comparator triggers, the device is set in shutdown state and both its outputs are set to low level leaving the half-bridge in tristate.

Figure 7. Smart shutdown timing waveforms

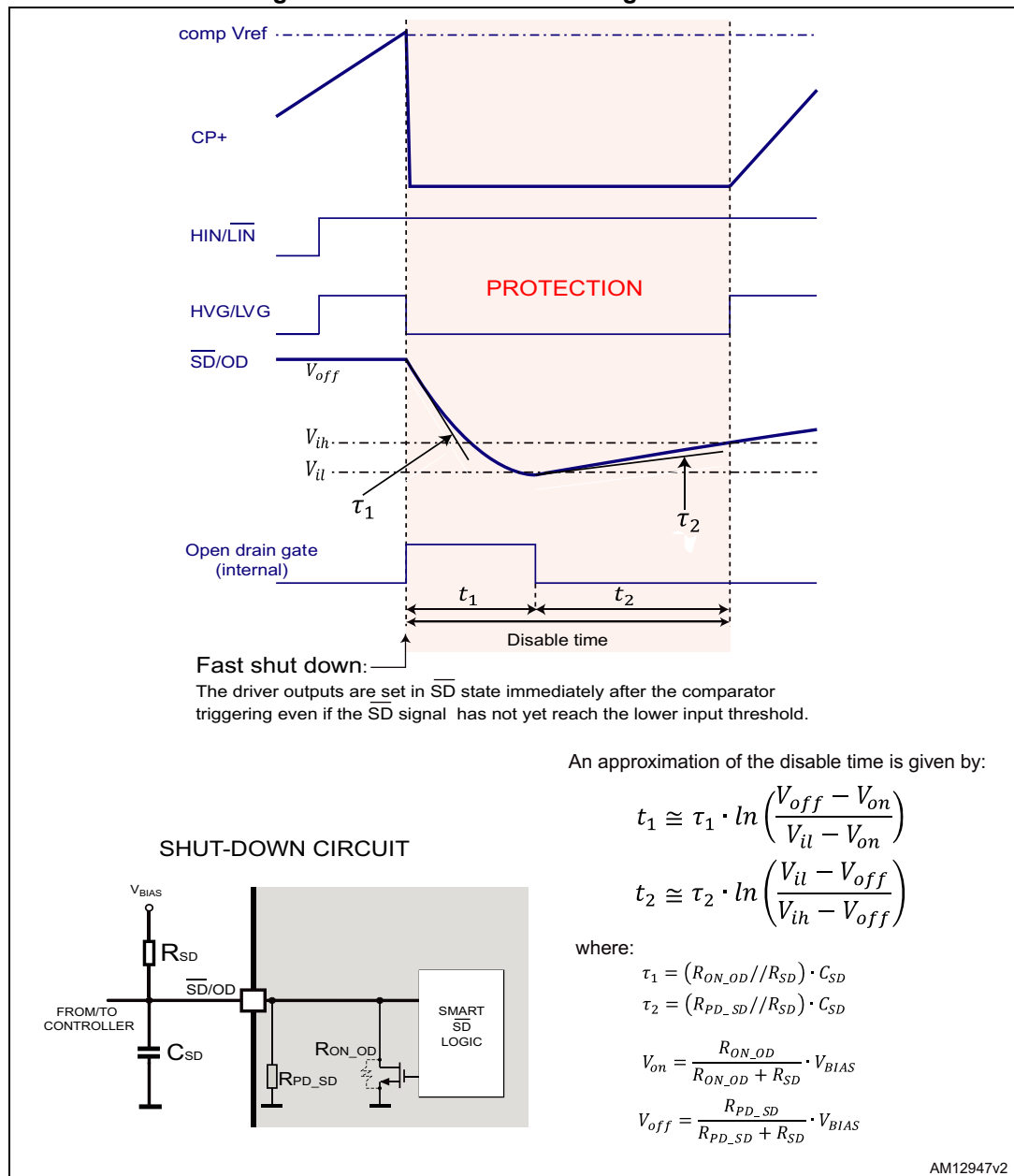

In common overcurrent protection architectures the comparator output is usually connected to the SD input and an RC network is connected to this SD/OD line in order to provide a monostable circuit, which implements a protection time that follows the fault condition. Differently from the common fault detection systems, the L6390 smart shutdown architecture allows immediate turn-off of the outputs of the gate driver in the case of fault, by minimizing the propagation delay between the fault detection event and the actual output switch-off. In fact, the time delay between the fault detection and the output turn-off is no longer dependent on the value of the external RC network connected to the SD/OD pin. In the smart shutdown circuitry the fault signal has a preferential path which directly switches off the outputs after the comparator triggering. At the same time the internal logic turns on the open drain output and holds it on until the SD voltage goes below the SD logic input lower threshold. When such threshold is reached, the open drain output is turned off, allowing the external pull-up to recharge the capacitor. The driver outputs restart following the input pins as soon as the voltage at the SD/OD pin reaches the higher threshold of the SD logic input. The smart shutdown system provides the possibility to increase the time constant of the external RC network (that determines the disable time after the fault event) up to very large values without increasing the delay time of the protection.

Any external signal provided to the SD pin is not latched and can be used as control signal in order to perform, for instance, PWM chopping through this pin. In fact when a PWM signal is applied to the SD input and the logic inputs of the gate driver are stable, the outputs switch from the low level to the state defined by the logic inputs and vice versa.

In some applications it may be useful to latch the driver in the shutdown condition for an arbitrary time, until the controller decides to reset it to normal operation. This may, for example, be achieved with a circuit similar to the one shown in Figure 8. When the open drain starts pulling down the SD/OD pin, the external latch turns on and keeps the pin to GND, preventing it from being pulled up again once the SD logic input lower threshold is reached and the internal open drain turns off. One pin of the controller is used to release the external latch, and one to externally force a shutdown condition and also to read the status of the SD/OD pin.

Figure 8. Protection latching example circuit

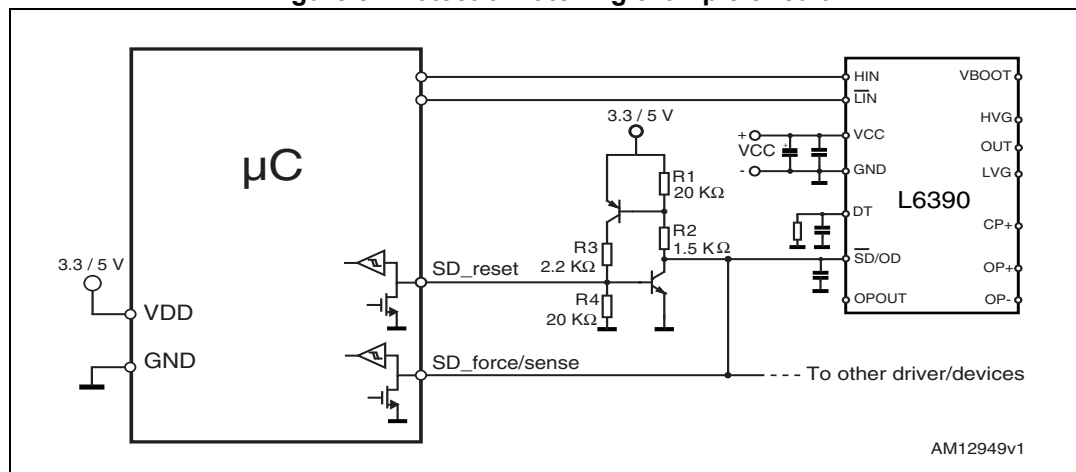

In applications using only one L6390 for the protection of several different legs (such as a single-shunt inverter, for example) it may be useful to implement the resistor divider shown in Figure 9. This simple network allows the pushing of the SD pins of the other devices to a voltage lower than L6390 V_{ij} , so that each device can reach its low logic level regardless of part-to-part variations of the thresholds.

8 Typical application diagram

Figure 10. Application diagram

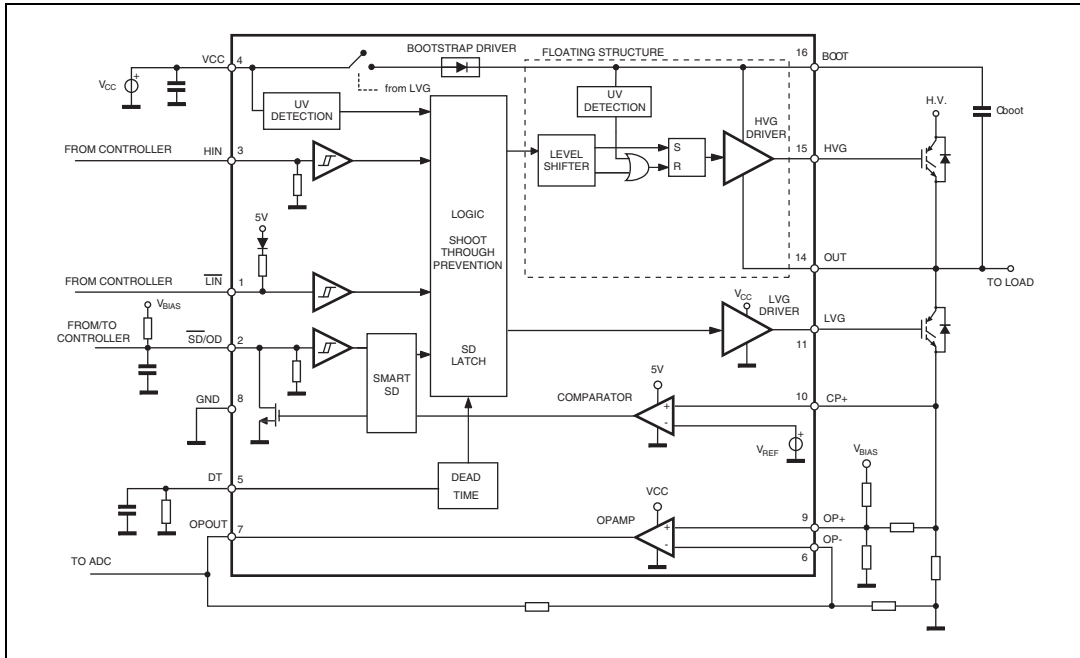

9 Bootstrap driver

A bootstrap circuitry is needed to supply the high voltage section. This function is normally accomplished by a high voltage fast recovery diode (*Figure 11.a*). In the L6390 device a patented integrated structure replaces the external diode. It is realized by a high voltage DMOS, driven synchronously with the low-side driver (LVG), with a diode in series, as shown in *Figure 11.b*. An internal charge pump (*Figure 11.b*) provides the DMOS driving voltage.

C_{BOOT} selection and charging

To choose the proper C_{BOOT} value the external MOS can be seen as an equivalent capacitor. This capacitor C_{EXT} is related to the MOS total gate charge:

Equation 1

$$C_{EXT} = \frac{Q_{gate}}{V_{gate}}$$

The ratio between the capacitors C_{EXT} and C_{BOOT} is proportional to the cyclical voltage loss. It must be:

Equation 2

$$C_{BOOT} \gg \gg C_{EXT}$$

E.g.: if Q_{gate} is 30 nC and V_{gate} is 10 V, C_{EXT} is 3 nF. With $C_{BOOT} = 100$ nF the drop would be 300 mV.

If HVG must be supplied for a long time, the C_{BOOT} selection must also take the leakage and quiescent losses into account.

E.g.: HVG steady-state consumption is lower than 240 μ A, so if HVG T_{ON} is 5 ms, C_{BOOT} must supply 1.2 μ C to C_{EXT} . This charge on a 1 μ F capacitor means a voltage drop of 1.2 V.

The internal bootstrap driver offers important advantages: the external fast recovery diode can be avoided (it usually has a high leakage current).

This structure can work only if V_{OUT} is close to GND (or lower) and, at the same time, the LVG is on. The charging time (T_{charge}) of the C_{BOOT} is the time in which both conditions are fulfilled and it must be long enough to charge the capacitor.

The bootstrap driver introduces a voltage drop due to the DMOS R_{DSon} (typical value: 120 Ω). This drop can be neglected at low switching frequency, but it should be taken into account when operating at high switching frequency.

The following equation is useful to compute the drop on the bootstrap DMOS:

Equation 3

$$V_{\text{drop}} = I_{\text{charge}} R_{\text{dson}} \rightarrow V_{\text{drop}} = \frac{Q_{\text{gate}}}{T_{\text{charge}}} R_{\text{dson}}$$

where Q_{gate} is the gate charge of the external power MOSFET, R_{dson} is the on-resistance of the bootstrap DMOS and T_{charge} is the charging time of the bootstrap capacitor.

For example: using a power MOSFET with a total gate charge of 30 nC, the drop on the bootstrap DMOS is about 1 V, if the T_{charge} is 5 μs . In fact:

Equation 4

$$V_{\text{drop}} = \frac{30\text{nC}}{5\mu\text{s}} \cdot 120\Omega \sim 0.7\text{V}$$

V_{drop} should be taken into account when the voltage drop on C_{BOOT} is calculated: if this drop is too high, or the circuit topology doesn't allow a sufficient charging time, an external diode can be used.

Figure 11. Bootstrap driver

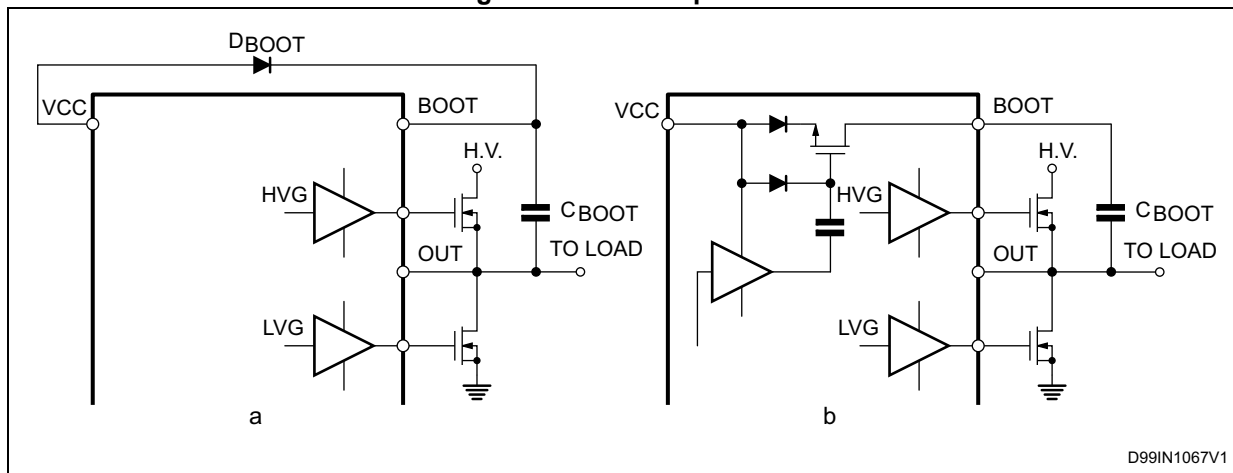

D99IN1067V1

10 Package information

In order to meet environmental requirements, ST offers these devices in different grades of ECOPACK® packages, depending on their level of environmental compliance. ECOPACK specifications, grade definitions and product status are available at: www.st.com. ECOPACK is an ST trademark.

10.1 SO-16 package information

Figure 12. SO-16 narrow package outline

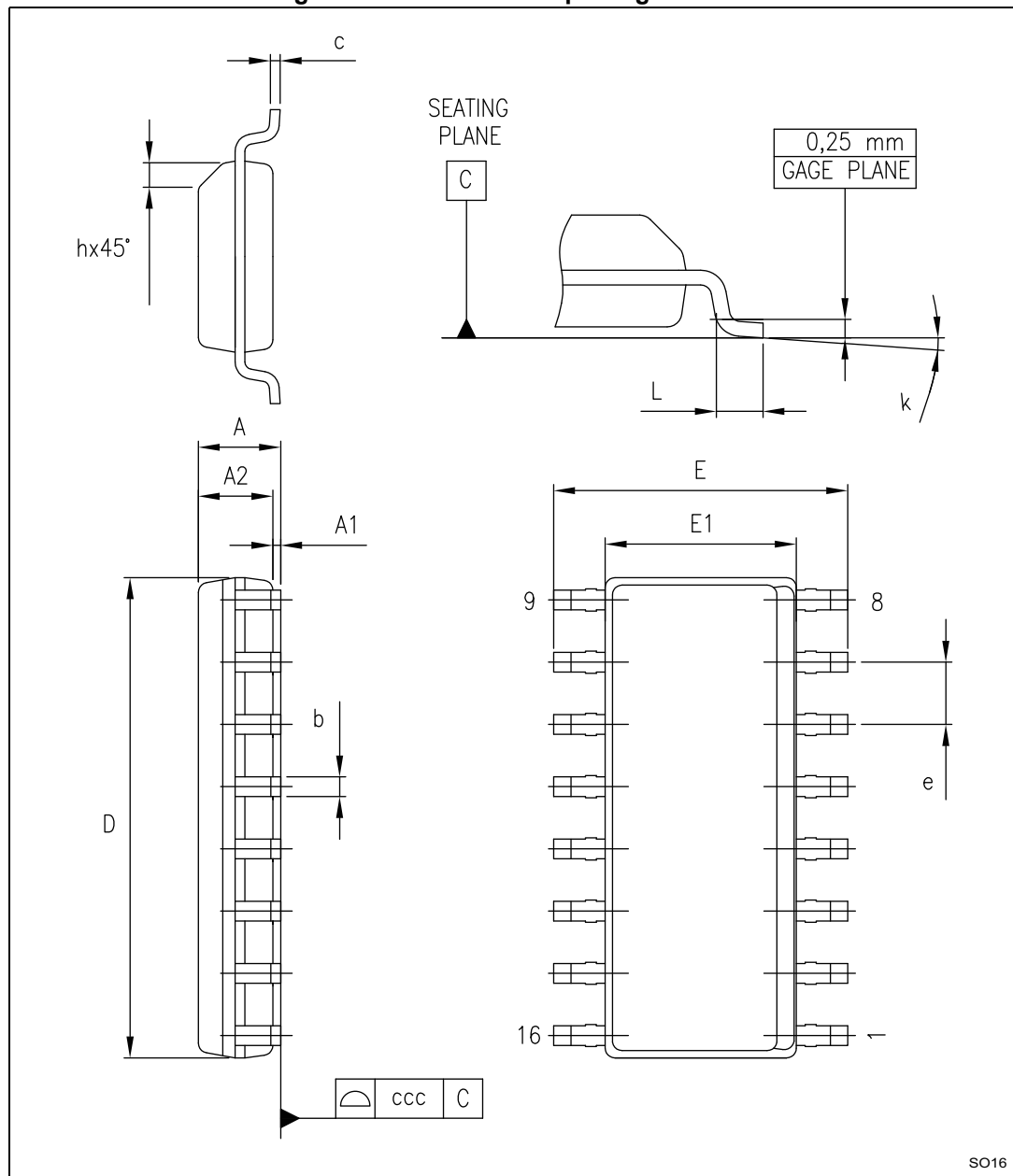

SO16

Table 10. SO-16 narrow package mechanical data

Symbol	Dimensions (mm)		
	Min.	Typ.	Max.
A	-	-	1.75
A1	0.10	-	0.25
A2	1.25	-	-
b	0.31	-	0.51
c	0.17	-	0.25
D	9.80	9.90	10.00
E	5.80	6.00	6.20
E1	3.80	3.90	4.00
e	-	1.27	-
h	0.25	-	0.50
L	0.40	-	1.27
k	0	-	8°
ccc	-	-	0.10

Figure 13. SO-16 narrow footprint

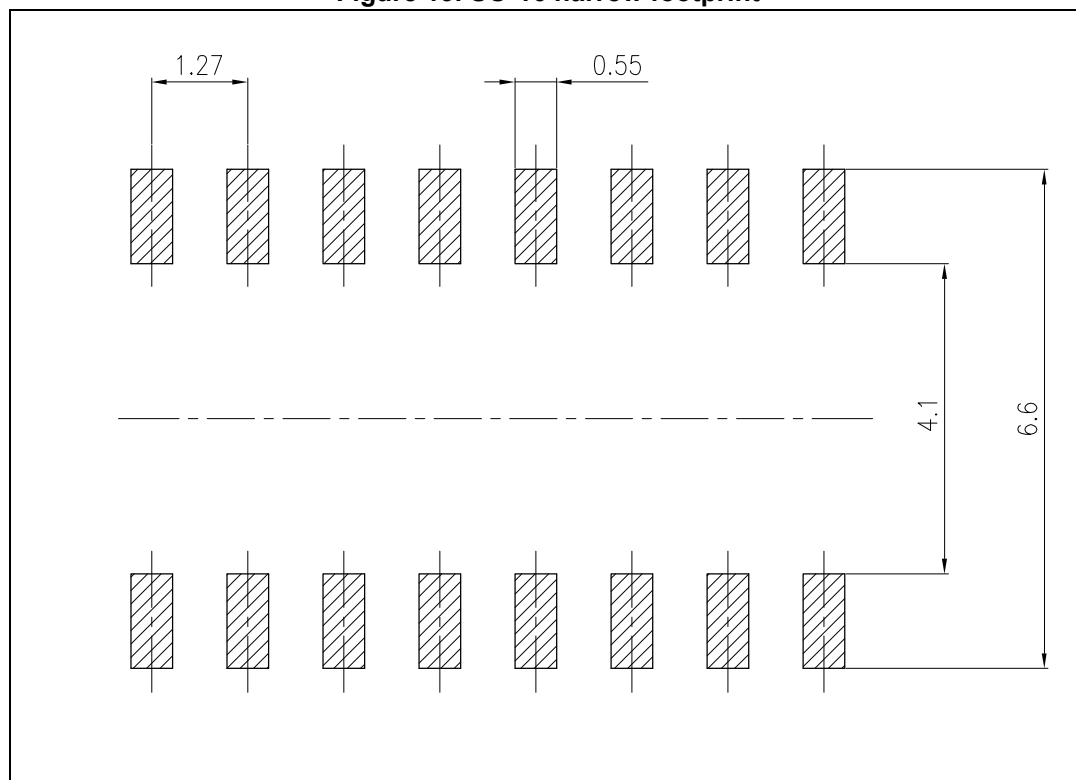

11 Order codes

Table 11. Order codes

Order code	Package	Packaging
L6390D	SO-16	Tube
L6390DTR	SO-16	Tape and reel

12 Revision history

Table 12. Document revision history

Date	Revision	Changes
20-Jun-2014	8	<p>Updated <i>Section : Applications on page 1</i> (replaced by new applications).</p> <p>Updated <i>Section : Description on page 1</i> (replaced by new description).</p> <p>Updated <i>Table 1: Device summary</i> (moved from page 1 to page 24, updated title to <i>Table 11: Order codes</i>).</p> <p>Updated <i>Section 4.1: Absolute maximum ratings on page 6</i> (removed note below <i>Table 3: Absolute maximum ratings</i>).</p> <p>Updated <i>Table 7 on page 10</i> (updated I_{QBO} max. value).</p> <p>Updated <i>Section : C_{BOOT} selection and charging on page 18</i> (updated values of "E.g.: HVG").</p> <p>Updated <i>Section 10: Package information on page 20</i> (updated titles, reversed order of <i>Figure 11 and Table 10</i>, <i>Figure 11 and Table 10</i>, updated headers of <i>Table 10 and Table 10</i>).</p> <p>Minor modifications throughout document.</p>
11-Sep-2015	9	<p>Removed DIP-16 package from the whole document.</p> <p>Updated <i>Table 3 on page 6</i> (added ESD parameter and value).</p> <p>Updated <i>Table 4 on page 6</i> (updated $R_{th(JA)}$ value).</p> <p>Updated note 1.and 2. below <i>Table 7 on page 10</i> (minor modifications, replaced V_{CBOOTx} by V_{BOOTx}).</p> <p>Minor modifications throughout document.</p>
07-Apr-2017	10	<p>Updated <i>Table 5 on page 7</i> (updated cross reference to <i>Figure 4 on page 12</i> instead of removed <i>Figure 3. Timing</i>).</p> <p>Updated <i>Table 6 on page 9</i> (added R_{PD_SD}) and <i>Table 8 on page 11</i> (added R_{ON_OD}).</p> <p>Updated <i>Section 5 on page 12</i> (updated title, added <i>Figure 4</i> and <i>Figure 5</i>).</p> <p>Added <i>Section 6 on page 14</i> (and moved <i>Table 9: Truth table</i> to this section).</p> <p>Updated <i>Figure 11 on page 20</i> and <i>Figure 12 on page 21</i> (replaced by new figure).</p> <p>Minor modifications throughout document.</p>

IMPORTANT NOTICE – PLEASE READ CAREFULLY

STMicroelectronics NV and its subsidiaries (“ST”) reserve the right to make changes, corrections, enhancements, modifications, and improvements to ST products and/or to this document at any time without notice. Purchasers should obtain the latest relevant information on ST products before placing orders. ST products are sold pursuant to ST’s terms and conditions of sale in place at the time of order acknowledgement.

Purchasers are solely responsible for the choice, selection, and use of ST products and ST assumes no liability for application assistance or the design of Purchasers’ products.

No license, express or implied, to any intellectual property right is granted by ST herein.

Resale of ST products with provisions different from the information set forth herein shall void any warranty granted by ST for such product.

ST and the ST logo are trademarks of ST. All other product or service names are the property of their respective owners.

Information in this document supersedes and replaces information previously supplied in any prior versions of this document.

© 2017 STMicroelectronics – All rights reserved

Mouser Electronics

Authorized Distributor

Click to View Pricing, Inventory, Delivery & Lifecycle Information:

[STMicroelectronics:](#)

[L6390D](#) [L6390DTR](#)