



MD1803DFX

High voltage NPN Power transistor for standard definition CRT display

Features

- State-of-the-art technology:
 - Diffused collector “enhanced generation”
- More stable performance versus operating temperature variation
- Low base drive requirement
- Tighter h_{FE} range at operating collector current
- Fully insulated power package U.L. compliant
- Integrated free wheeling diode
- In compliance with the 2002/93/EC european directive

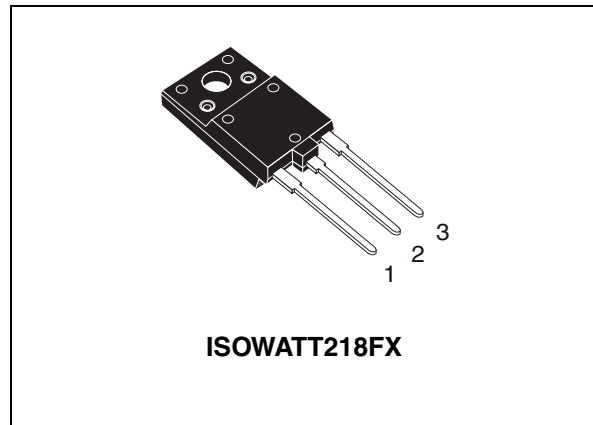

Applications

- Horizontal deflection output for TV

Description

The MD1803DFX is manufactured using Diffused Collector in Planar Technology adopting new and enhanced high voltage structure. The new MD product series show improved silicon efficiency bringing updated performance to the Horizontal Deflection stage.

Internal schematic diagram

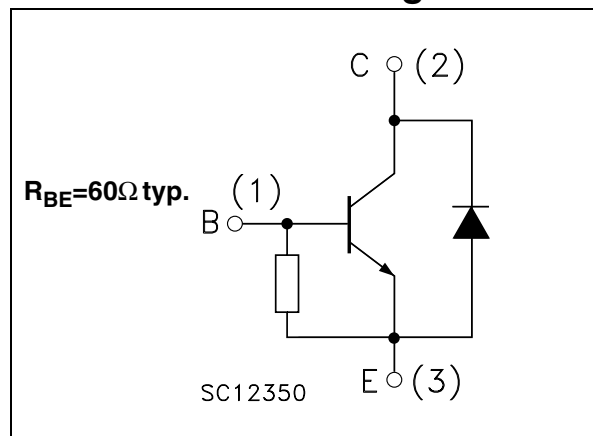

Order codes

Part number	Marking	Package	Packing
MD1803DFX	MD1803DFX	ISOWATT218FX	TUBE

1 Electrical ratings

Table 1. Absolute maximum rating

Symbol	Parameter	Value	Unit
V_{CES}	Collector-emitter voltage ($V_{BE} = 0$)	1500	V
V_{CEO}	Collector-emitter voltage ($I_B = 0$)	700	V
V_{EBO}	Emitter-base voltage ($I_C = 0$)	10	V
I_C	Collector current	10	A
I_{CM}	Collector peak current ($t_p < 5\text{ms}$)	15	A
I_B	Base current	5	A
P_{TOT}	Total dissipation at $T_c = 25^\circ\text{C}$	57	W
V_{isol}	Insulation withstand voltage (rms) from all three leads to external heatsink	2500	V
T_{stg}	Storage temperature	-65 to 150	°C
T_J	Max. operating junction temperature		

Table 2. Thermal data

Symbol	Parameter	Value	Unit
$R_{thj-case}$	Thermal resistance junction-case	Max 2.2	°C/W

2 Electrical characteristics

($T_{CASE} = 25^{\circ}C$; unless otherwise specified)

Table 3. Electrical characteristics

Symbol	Parameter	Test conditions	Min.	Typ.	Max.	Unit
I_{CES}	Collector cut-off current ($V_{BE} = 0$)	$V_{CE} = 1500V$			0.2	mA
		$V_{CE} = 1500V$ $T_C = 125^{\circ}C$			2	mA
I_{EBO}	Emitter cut-off current ($I_C = 0$)	$V_{EB} = 5V$	40		120	mA
$V_{(BR)EBO}$	Emitter-base breakdown voltage ($I_C = 0$)	$I_E = 700\text{ mA}$	10			V
$V_{CE(sat)}$ <i>Note 1</i>	Collector-emitter saturation voltage	$I_C = 5\text{ A}$ $I_B = 1.25\text{ A}$			2	V
$V_{BE(sat)}$ <i>Note 1</i>	Base-emitter saturation voltage	$I_C = 5\text{ A}$ $I_B = 1.25\text{ A}$			1.2	V
h_{FE} <i>Note 1</i>	DC current gain	$I_C = 1\text{ A}$ $V_{CE} = 5\text{ V}$		18		
		$I_C = 5\text{ A}$ $V_{CE} = 1\text{ V}$		5		
		$I_C = 5\text{ A}$ $V_{CE} = 5\text{ V}$	5.5		7.5	
V_f	Diode forward voltage	$I_F = 5\text{ A}$			1.6	V
t_s t_f	Inductive load	$I_C = 4\text{ A}$ $f_h = 16\text{ KHz}$				
	Storage time	$I_{B(on)} = 0.6\text{ A}$ $V_{BE(off)} = -2.7\text{ V}$		2.5	3	μs
	Fall time	$L_{BB(off)} = 4.5\mu\text{H}$		0.3	0.6	μs

1 Pulsed duration = 300 μs , duty cycle $\leq 1.5\%$.

2.1 Electrical characteristics (curve)

Figure 1. Safe operating area

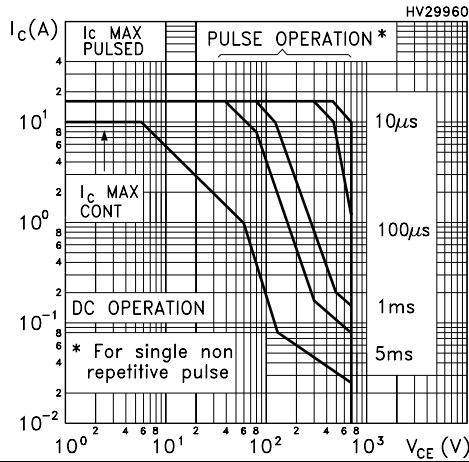

Figure 3. Output characteristics

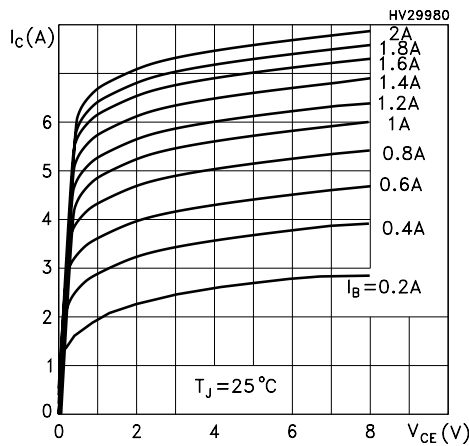

Figure 5. DC current gain

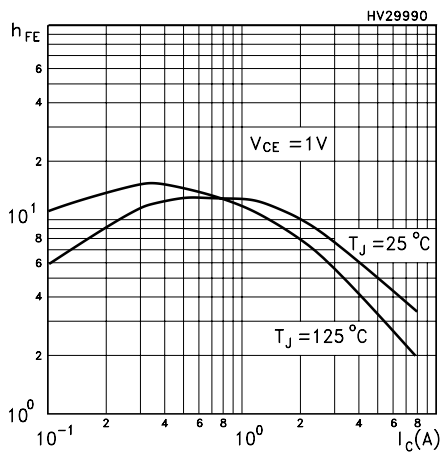

Figure 2. Derating curve

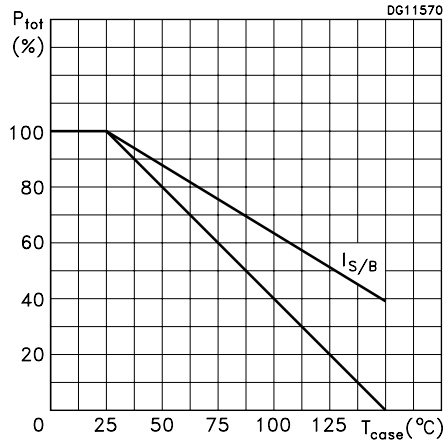

Figure 4. Reverse biased SOA

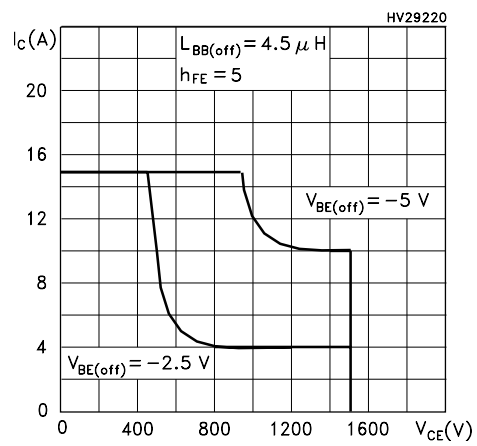

Figure 6. DC current gain

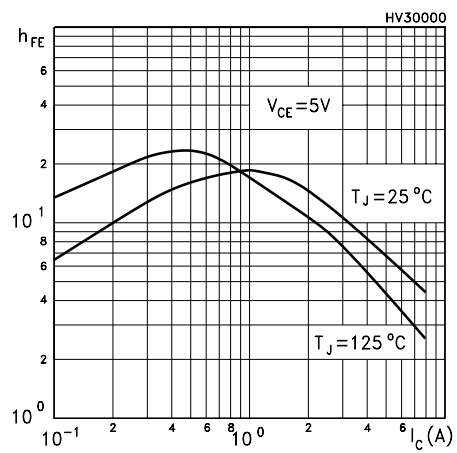

Figure 7. Collector-emitter saturation voltage Figure 8. Base-emitter saturation voltage

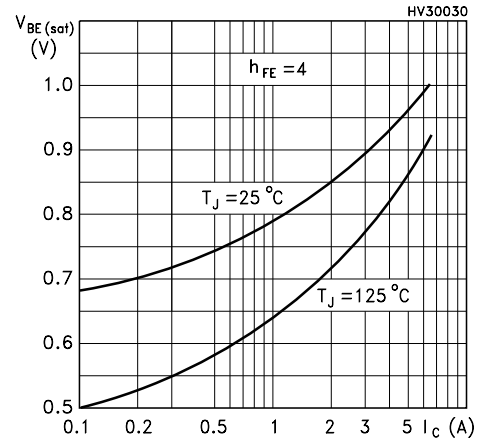
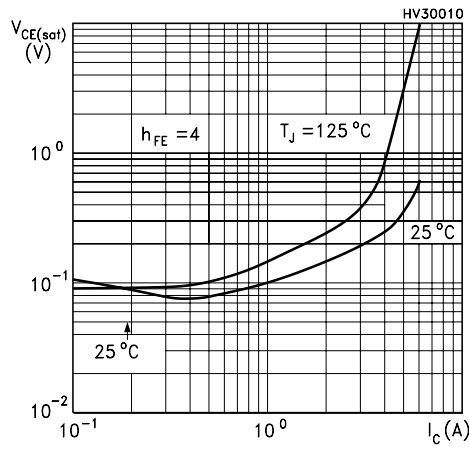

Figure 9. Power losses

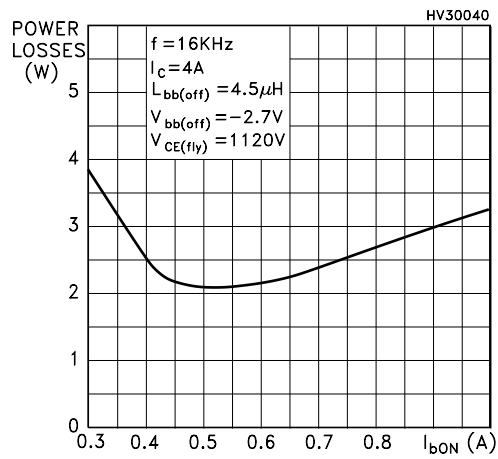
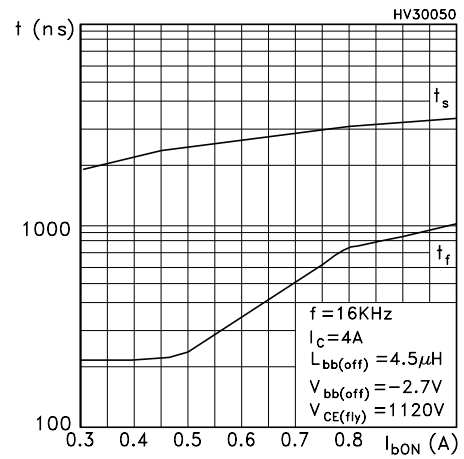

Figure 10. Inductive load switching time



2.2 Test circuit

Figure 11. Power losses and inductive load switching test circuit

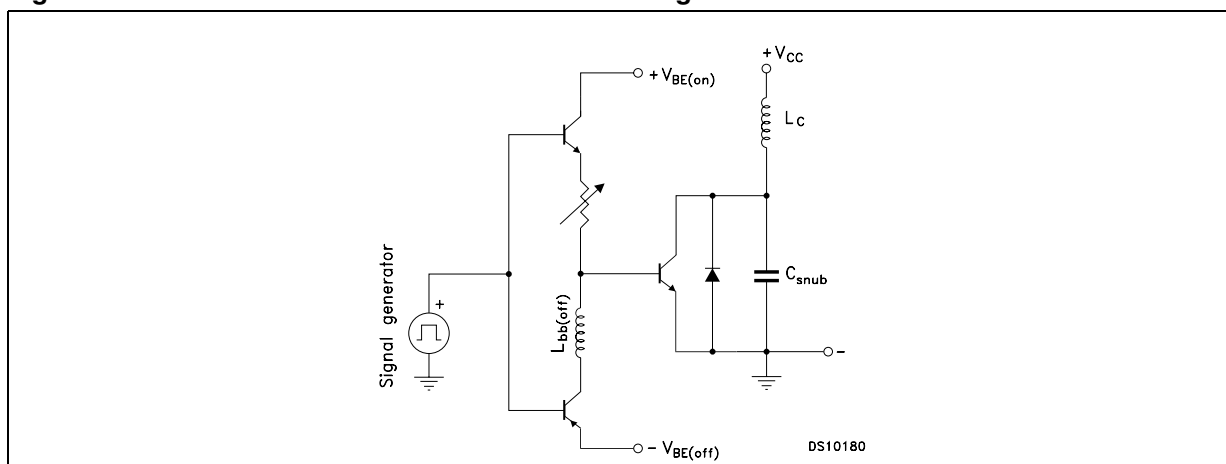
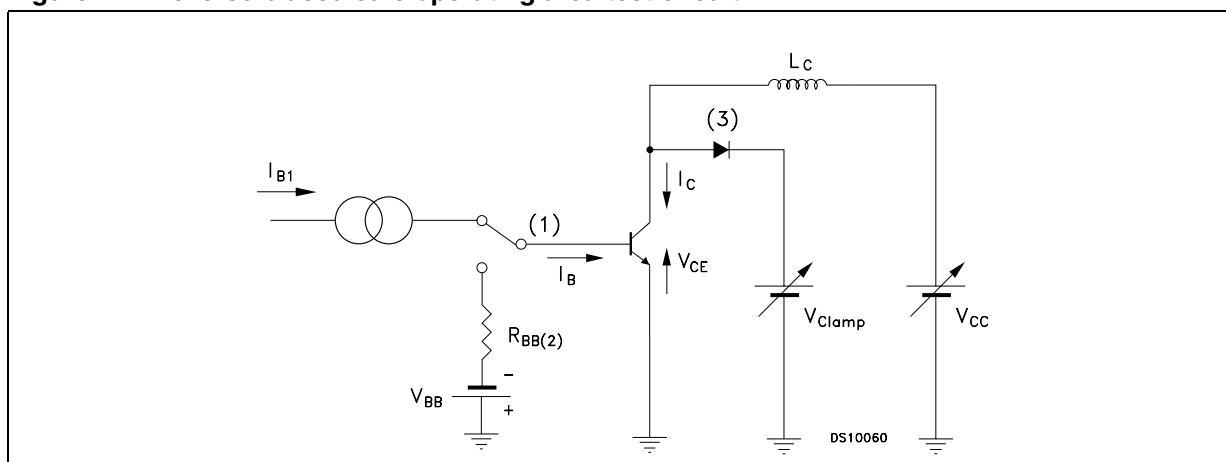

Figure 12. Reverse biased safe operating area test circuit



3 Package mechanical data

In order to meet environmental requirements, ST offers these devices in ECOPACK® packages. These packages have a Lead-free second level interconnect . The category of second level interconnect is marked on the package and on the inner box label, in compliance with JEDEC Standard JESD97. The maximum ratings related to soldering conditions are also marked on the inner box label. ECOPACK is an ST trademark. ECOPACK specifications are available at: www.st.com

ISOWATT218FX MECHANICAL DATA

DIM.	mm.		
	MIN.	TYP	MAX.
A	5.30		5.70
C	2.80		3.20
D	3.10		3.50
D1	1.80		2.20
E	0.80		1.10
F	0.65		0.95
F2	1.80		2.20
G	10.30		11.50
G1		5.45	
H	15.30		15.70
L	9		10.20
L2	22.80		23.20
L3	26.30		26.70
L4	43.20		44.40
L5	4.30		4.70
L6	24.30		24.70
L7	14.60		15
N	1.80		2.20
R	3.80		4.20
Dia	3.40		3.80

