

SN54BCT760, SN74BCT760 OCTAL BUFFERS/DRIVERS WITH OPEN-COLLECTOR OUTPUTS

SCBS034B – JULY 1989 – REVISED NOVEMBER 1993

- Open-Collector Version of 'BCT244
- Open-Collector Outputs Drive Bus Lines or Buffer Memory Address Registers
- ESD Protection Exceeds 2000 V Per MIL-STD-883C Method 3015
- Packages Options Include Plastic Small-Outline (DW) Packages, Ceramic Chip Carriers (FK) and Flatpacks (W), and Standard Plastic and Ceramic 300-mil DIPs (J, N)

description

These octal buffers and line drivers are designed specifically to improve both the performance and density of 3-state memory address drivers, clock drivers, and bus-oriented receivers and transmitters.

The 'BCT760 is organized as two 4-bit buffers/line drivers with separate output-enable (\overline{OE}) inputs. When \overline{OE} is low, the device passes data from the A inputs to the Y outputs. When \overline{OE} is high, the outputs are in the high-impedance state.

The SN54BCT760 is characterized for operation over the full military temperature range of -55°C to 125°C . The SN74BCT760 is characterized for operation from 0°C to 70°C .

SN54BCT760 . . . J OR W PACKAGE
SN74BCT760 . . . DW OR N PACKAGE
(TOP VIEW)

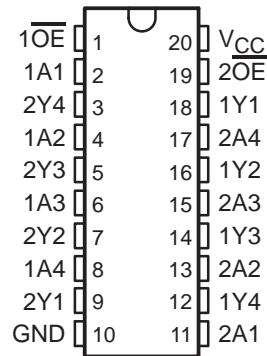

SN54BCT760 . . . FK PACKAGE
(TOP VIEW)

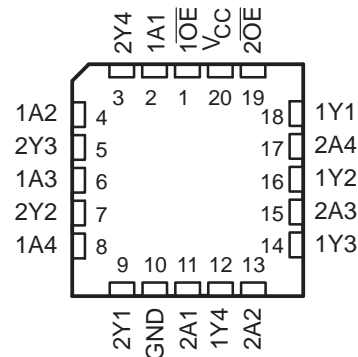

FUNCTION TABLE
(each buffer)

INPUTS		OUTPUT
\overline{OE}	A	Y
L	H	H
L	L	L
H	X	H

SN54BCT760, SN74BCT760 OCTAL BUFFERS/DRIVERS WITH OPEN-COLLECTOR OUTPUTS

SCBS034B – JULY 1989 – REVISED NOVEMBER 1993

logic symbol†

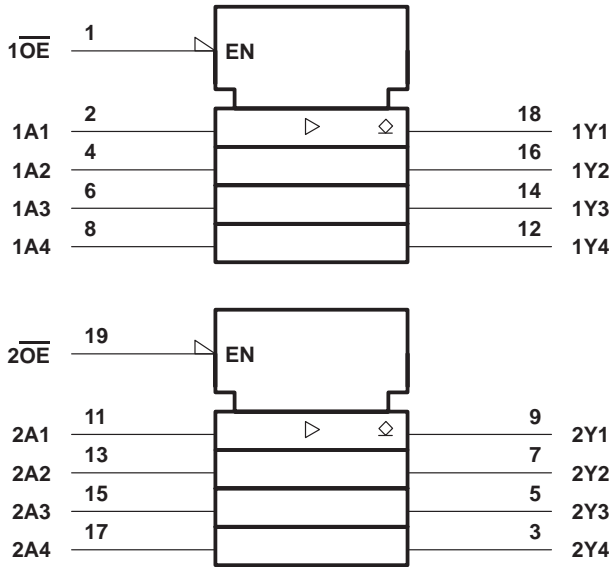

† This symbol is in accordance with ANSI/IEEE Std 91-1984 and IEC Publication 617-12.

logic diagram (positive logic)

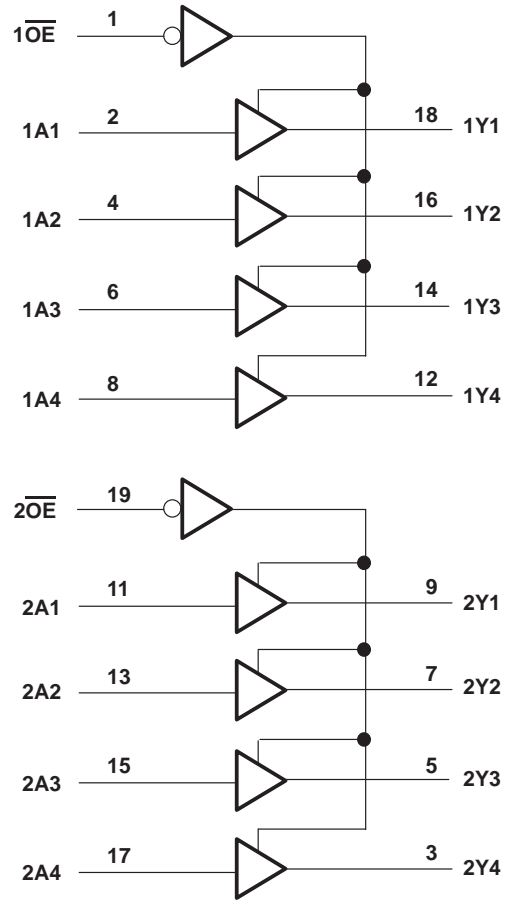

absolute maximum ratings over operating free-air temperature range (unless otherwise noted)‡

Supply voltage range, V_{CC}	- 0.5 V to 7 V
Input voltage range, V_I (see Note 1)	- 0.5 V to 7 V
Input current range, I_I	- 30 mA to 5 mA
Voltage range applied to any output in the disabled or power-off state, V_O	- 0.5 V to 5.5 V
Voltage range applied to any output in the high state, V_{OH}	- 0.5 V to V_{CC}
Current into any output in the low state: SN54BCT760	96 mA
SN74BCT760	128 mA
Operating free-air temperature range: SN54BCT760	- 55°C to 125°C
SN74BCT760	0°C to 70°C
Storage temperature range	- 65°C to 150°C

‡ Stresses beyond those listed under "absolute maximum ratings" may cause permanent damage to the device. These are stress ratings only, and functional operation of the device at these or any other conditions beyond those indicated under "recommended operating conditions" is not implied. Exposure to absolute-maximum-rated conditions for extended periods may affect device reliability.

NOTE 1: The negative input voltage rating may be exceeded if the input clamp current rating is observed.

SN54BCT760, SN74BCT760
OCTAL BUFFERS/DRIVERS
WITH OPEN-COLLECTOR OUTPUTS
 SCBS034B – JULY 1989 – REVISED NOVEMBER 1993

recommended operating conditions

		SN54BCT760			SN74BCT760			UNIT
		MIN	NOM	MAX	MIN	NOM	MAX	
V _{CC}	Supply voltage	4.5	5	5.5	4.5	5	5.5	V
V _{IH}	High-level input voltage	2			2			V
V _{IL}	Low-level input voltage			0.8			0.8	V
V _{OH}	High-level output voltage			5.5			5.5	V
I _{IK}	Input clamp current			-18			-18	mA
I _{OL}	Low-level output current			48			64	mA
T _A	Operating free-air temperature	-55		125	0		70	°C

electrical characteristics over recommended operating free-air temperature range (unless otherwise noted)

PARAMETER	TEST CONDITIONS		SN54BCT760			SN74BCT760			UNIT
			MIN	TYP†	MAX	MIN	TYP†	MAX	
V _{IK}	V _{CC} = 4.5 V,	I _I = -18 mA			-1.2			-1.2	V
V _{OL}	V _{CC} = 4.5 V	I _{OL} = 48 mA	0.38	0.55					V
		I _{OL} = 64 mA				0.42	0.55		
I _I	V _{CC} = 5.5 V,	V _I = 7 V			0.1			0.1	mA
I _{IH}	V _{CC} = 5.5 V,	V _I = 2.7 V			20			20	μA
I _{IL}	V _{CC} = 5.5 V,	V _I = 0.5 V			-1			-1	mA
I _{OH}	V _{CC} = 4.5 V,	V _{OH} = 5.5 V			0.1			0.1	mA
I _{CC}	V _{CC} = 5.5 V,	Outputs high	21	33		21	33		mA
		Outputs low	48	76		48	76		
		$\overline{\text{OE}}$ disabled	6	10		6	10		
C _i	V _{CC} = 5 V,	V _I = 2.5 V or 0.5 V		6			6		pF
C _o	V _{CC} = 5 V,	V _I = 2.5 V or 0.5 V		10			10		pF

† All typical values are at V_{CC} = 5 V, T_A = 25°C.

switching characteristics (see Note 2)

PARAMETER	FROM (INPUT)	TO (OUTPUT)	V _{CC} = 5 V, C _L = 50 pF, R _L = 500 Ω, T _A = 25°C			V _{CC} = 4.5 V to 5.5 V, C _L = 50 pF, R _L = 500 Ω, T _A = MIN to MAX‡				UNIT
			'BCT760			SN54BCT760		SN74BCT760		
			MIN	TYP	MAX	MIN	MAX	MIN	MAX	
t _{PLH}	Any A	Y	6.3	8	9.5	6.3	11.1	6.3	10	ns
t _{PHL}			2.1	4.3	6.5	2.1	7.7	2.1	7.2	
t _{PLH}	$\overline{\text{OE}}$	Y	8.6	13	15.2	8.6	18.7	8.6	17.5	ns
t _{PHL}			3.2	6.2	8.9	3.2	10.4	3.2	9.9	

‡ For conditions shown as MIN or MAX, use the appropriate values specified under recommended operating conditions.

NOTE 2: Load circuits and voltage waveforms are shown in Section 1.



PACKAGING INFORMATION

Orderable Device	Status (1)	Package Type	Package Drawing	Pins	Package Qty	Eco Plan (2)	Lead finish/ Ball material (6)	MSL Peak Temp (3)	Op Temp (°C)	Device Marking (4/5)	Samples
5962-9093801M2A	ACTIVE	LCCC	FK	20	1	Non-RoHS & Green	SNPB	N / A for Pkg Type	-55 to 125	5962- 9093801M2A SNJ54BCT 760FK	Samples
5962-9093801MRA	ACTIVE	CDIP	J	20	1	Non-RoHS & Green	SNPB	N / A for Pkg Type	-55 to 125	5962-9093801MR A SNJ54BCT760J	Samples
5962-9093801MSA	ACTIVE	CFP	W	20	1	Non-RoHS & Green	SNPB	N / A for Pkg Type	-55 to 125	5962-9093801MS A SNJ54BCT760W	Samples
SN54BCT760J	ACTIVE	CDIP	J	20	1	Non-RoHS & Green	SNPB	N / A for Pkg Type	-55 to 125	SN54BCT760J	Samples
SN74BCT760DW	ACTIVE	SOIC	DW	20	25	RoHS & Green	NIPDAU	Level-1-260C-UNLIM	0 to 70	BCT760	Samples
SN74BCT760DWR	ACTIVE	SOIC	DW	20	2000	RoHS & Green	NIPDAU	Level-1-260C-UNLIM	0 to 70	BCT760	Samples
SN74BCT760N	ACTIVE	PDIP	N	20	20	RoHS & Non-Green	NIPDAU	N / A for Pkg Type	0 to 70	SN74BCT760N	Samples
SNJ54BCT760FK	ACTIVE	LCCC	FK	20	1	Non-RoHS & Green	SNPB	N / A for Pkg Type	-55 to 125	5962- 9093801M2A SNJ54BCT 760FK	Samples
SNJ54BCT760J	ACTIVE	CDIP	J	20	1	Non-RoHS & Green	SNPB	N / A for Pkg Type	-55 to 125	5962-9093801MR A SNJ54BCT760J	Samples
SNJ54BCT760W	ACTIVE	CFP	W	20	1	Non-RoHS & Green	SNPB	N / A for Pkg Type	-55 to 125	5962-9093801MS A SNJ54BCT760W	Samples

(1) The marketing status values are defined as follows:

ACTIVE: Product device recommended for new designs.

LIFEBUY: TI has announced that the device will be discontinued, and a lifetime-buy period is in effect.

NRND: Not recommended for new designs. Device is in production to support existing customers, but TI does not recommend using this part in a new design.

PREVIEW: Device has been announced but is not in production. Samples may or may not be available.

OBSELETE: TI has discontinued the production of the device.

(2) **RoHS:** TI defines "RoHS" to mean semiconductor products that are compliant with the current EU RoHS requirements for all 10 RoHS substances, including the requirement that RoHS substance do not exceed 0.1% by weight in homogeneous materials. Where designed to be soldered at high temperatures, "RoHS" products are suitable for use in specified lead-free processes. TI may reference these types of products as "Pb-Free".

RoHS Exempt: TI defines "RoHS Exempt" to mean products that contain lead but are compliant with EU RoHS pursuant to a specific EU RoHS exemption.

Green: TI defines "Green" to mean the content of Chlorine (Cl) and Bromine (Br) based flame retardants meet JS709B low halogen requirements of ≤ 1000 ppm threshold. Antimony trioxide based flame retardants must also meet the ≤ 1000 ppm threshold requirement.

(3) MSL, Peak Temp. - The Moisture Sensitivity Level rating according to the JEDEC industry standard classifications, and peak solder temperature.

(4) There may be additional marking, which relates to the logo, the lot trace code information, or the environmental category on the device.

(5) Multiple Device Markings will be inside parentheses. Only one Device Marking contained in parentheses and separated by a "~" will appear on a device. If a line is indented then it is a continuation of the previous line and the two combined represent the entire Device Marking for that device.

(6) Lead finish/Ball material - Orderable Devices may have multiple material finish options. Finish options are separated by a vertical ruled line. Lead finish/Ball material values may wrap to two lines if the finish value exceeds the maximum column width.

Important Information and Disclaimer: The information provided on this page represents TI's knowledge and belief as of the date that it is provided. TI bases its knowledge and belief on information provided by third parties, and makes no representation or warranty as to the accuracy of such information. Efforts are underway to better integrate information from third parties. TI has taken and continues to take reasonable steps to provide representative and accurate information but may not have conducted destructive testing or chemical analysis on incoming materials and chemicals. TI and TI suppliers consider certain information to be proprietary, and thus CAS numbers and other limited information may not be available for release.

In no event shall TI's liability arising out of such information exceed the total purchase price of the TI part(s) at issue in this document sold by TI to Customer on an annual basis.

OTHER QUALIFIED VERSIONS OF SN54BCT760, SN74BCT760 :

- Catalog : [SN74BCT760](#)

- Enhanced Product : [SN74BCT760-EP](#), [SN74BCT760-EP](#)

- Military : [SN54BCT760](#)

NOTE: Qualified Version Definitions:

- Catalog - TI's standard catalog product

- Enhanced Product - Supports Defense, Aerospace and Medical Applications

- Military - QML certified for Military and Defense Applications

TAPE AND REEL INFORMATION

QUADRANT ASSIGNMENTS FOR PIN 1 ORIENTATION IN TAPE

*All dimensions are nominal

Device	Package Type	Package Drawing	Pins	SPQ	Reel Diameter (mm)	Reel Width W1 (mm)	A0 (mm)	B0 (mm)	K0 (mm)	P1 (mm)	W (mm)	Pin1 Quadrant
SN74BCT760DWR	SOIC	DW	20	2000	330.0	24.4	10.8	13.3	2.7	12.0	24.0	Q1

TAPE AND REEL BOX DIMENSIONS

*All dimensions are nominal

Device	Package Type	Package Drawing	Pins	SPQ	Length (mm)	Width (mm)	Height (mm)
SN74BCT760DWR	SOIC	DW	20	2000	367.0	367.0	45.0

TUBE

*All dimensions are nominal

Device	Package Name	Package Type	Pins	SPQ	L (mm)	W (mm)	T (μm)	B (mm)
5962-9093801M2A	FK	LCCC	20	1	506.98	12.06	2030	NA
5962-9093801MSA	W	CFP	20	1	506.98	26.16	6220	NA
SN74BCT760DW	DW	SOIC	20	25	507	12.83	5080	6.6
SN74BCT760N	N	PDIP	20	20	506	13.97	11230	4.32
SNJ54BCT760FK	FK	LCCC	20	1	506.98	12.06	2030	NA
SNJ54BCT760W	W	CFP	20	1	506.98	26.16	6220	NA

W (R-GDFP-F20)

CERAMIC DUAL FLATPACK



- NOTES:
- A. All linear dimensions are in inches (millimeters).
 - B. This drawing is subject to change without notice.
 - C. This package can be hermetically sealed with a ceramic lid using glass frit.
 - D. Index point is provided on cap for terminal identification only.
 - E. Falls within Mil-Std 1835 GDFP2-F20

N (R-PDIP-T**)

PLASTIC DUAL-IN-LINE PACKAGE

16 PINS SHOWN



- NOTES:
- A. All linear dimensions are in inches (millimeters).
 - B. This drawing is subject to change without notice.
 - $\triangle C$ Falls within JEDEC MS-001, except 18 and 20 pin minimum body length (Dim A).
 - $\triangle D$ The 20 pin end lead shoulder width is a vendor option, either half or full width.

4040049/E 12/2002

DW0020A



PACKAGE OUTLINE

SOIC - 2.65 mm max height

SOIC



4220724/A 05/2016

NOTES:

1. All linear dimensions are in millimeters. Dimensions in parenthesis are for reference only. Dimensioning and tolerancing per ASME Y14.5M.
2. This drawing is subject to change without notice.
3. This dimension does not include mold flash, protrusions, or gate burrs. Mold flash, protrusions, or gate burrs shall not exceed 0.15 mm per side.
4. This dimension does not include interlead flash. Interlead flash shall not exceed 0.43 mm per side.
5. Reference JEDEC registration MS-013.

EXAMPLE BOARD LAYOUT

DW0020A

SOIC - 2.65 mm max height

SOIC



LAND PATTERN EXAMPLE
SCALE:6X



SOLDER MASK DETAILS

4220724/A 05/2016

NOTES: (continued)

- 6. Publication IPC-7351 may have alternate designs.
- 7. Solder mask tolerances between and around signal pads can vary based on board fabrication site.

EXAMPLE STENCIL DESIGN

DW0020A

SOIC - 2.65 mm max height

SOIC



SOLDER PASTE EXAMPLE
BASED ON 0.125 mm THICK STENCIL
SCALE:6X

4220724/A 05/2016

NOTES: (continued)

8. Laser cutting apertures with trapezoidal walls and rounded corners may offer better paste release. IPC-7525 may have alternate design recommendations.
9. Board assembly site may have different recommendations for stencil design.