

TOSHIBA Transistor Silicon NPN Triple Diffused Type (Darlington power transistor)

2SD1525

High Current Switching Applications

- High collector current: $I_C = 30\text{ A}$
- High DC current gain: $h_{FE} = 1000\text{ (min)}$ ($V_{CE} = 5\text{ V}$, $I_C = 20\text{ A}$)
- Monolithic construction with built-in base-emitter shunt resistor.

Maximum Ratings ($T_a = 25^\circ\text{C}$)

Characteristics	Symbol	Rating	Unit
Collector-base voltage	V_{CBO}	100	V
Collector-emitter voltage	V_{CEO}	100	V
Emitter-base voltage	V_{EBO}	5	V
Collector current	I_C	30	A
Base current	I_B	5	A
Collector power dissipation ($T_c = 25^\circ\text{C}$)	P_C	150	W
Junction temperature	T_j	150	$^\circ\text{C}$
Storage temperature range	T_{stg}	-55 to 150	$^\circ\text{C}$

Equivalent Circuit

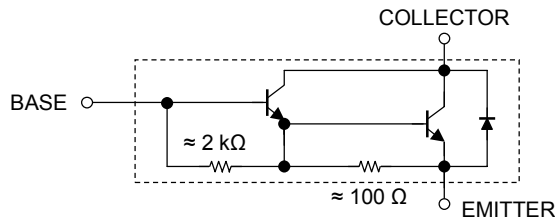

Unit: mm

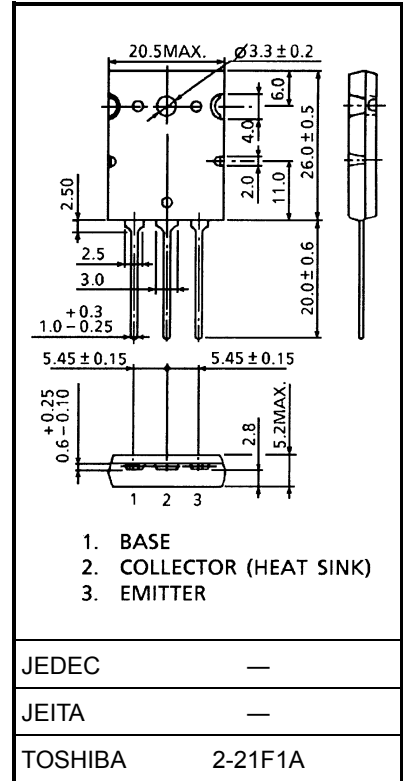

Weight: 9.75 g (typ.)

Electrical Characteristics (Ta = 25°C)

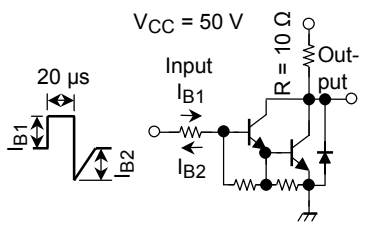
Characteristics		Symbol	Test Condition	Min	Typ.	Max	Unit
Collector cut-off current		I_{CBO}	$V_{CB} = 100\text{ V}, I_E = 0$	—	—	100	μA
Emitter cut-off current		I_{EBO}	$V_{EB} = 5\text{ V}, I_C = 0$	—	—	10	mA
Collector-emitter breakdown voltage		$V_{(BR)CEO}$	$I_C = 50\text{ mA}, I_B = 0$	100	—	—	V
DC current gain		$h_{FE(1)}$	$V_{CE} = 5\text{ V}, I_C = 20\text{ A}$	1000	—	—	
		$h_{FE(2)}$	$V_{CE} = 5\text{ V}, I_C = 30\text{ A}$	200	—	—	
Collector-emitter saturation voltage		$V_{CE(sat)}$	$I_C = 20\text{ A}, I_B = 0.2\text{ A}$	—	—	1.5	V
Base-emitter saturation voltage		$V_{BE(sat)}$		—	—	2.5	V
Emitter-collector forward voltage		V_{ECF}	$I_E = 10\text{ A}, I_B = 0$	—	—	3	V
Transition frequency		f_T	$V_{CE} = 5\text{ V}, I_C = 1\text{ A}$	—	10	—	MHz
Collector output capacitance		C_{ob}	$V_{CB} = 10\text{ V}, I_E = 0, f = 1\text{ MHz}$	—	500	—	pF
Switching time	Turn-on time	t_{on}	 <p>$V_{CC} = 50\text{ V}$ $R = 10\ \Omega$ Input I_{B1} I_{B2} Output $I_{B1} = -I_{B2} = 0.01\text{ A}, \text{ duty cycle } \leq 1\%$</p>	—	1.5	—	μs
	Storage time	t_{stg}		—	10	—	
	Fall time	t_f		—	1.5	—	

Marking

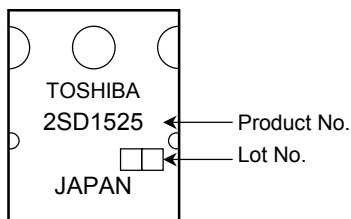

Explanation of Lot No.

