

GT60N321

High Power Switching Applications
The 4th Generation

Unit: mm

- FRD included between emitter and collector
- Enhancement-mode
- High speed IGBT : $t_f = 0.25 \mu s$ (typ.) ($I_C = 60 A$)
FRD : $t_{rr} = 0.8 \mu s$ (typ.) ($di/dt = -20 A/\mu s$)
- Low saturation voltage: $V_{CE(sat)} = 2.3 V$ (typ.) ($I_C = 60 A$)

Maximum Ratings (Ta = 25°C)

Characteristics	symbol	Rating	Unit
Collector-Emitter Voltage	V_{CES}	1000	V
Gate-Emitter Voltage	V_{GES}	±25	V
Collector Current	DC	I_C	60
	1 ms	I_{CP}	120
Emitter-Collector Forward Current	DC	I_{ECF}	15
	1 ms	I_{ECFP}	120
Collector Power Dissipation (Tc = 25°C)	P_C	170	W
Junction Temperature	T_j	150	°C
Storage Temperature	T_{stg}	-55~150	°C
Screw Torque	—	0.8	N·m

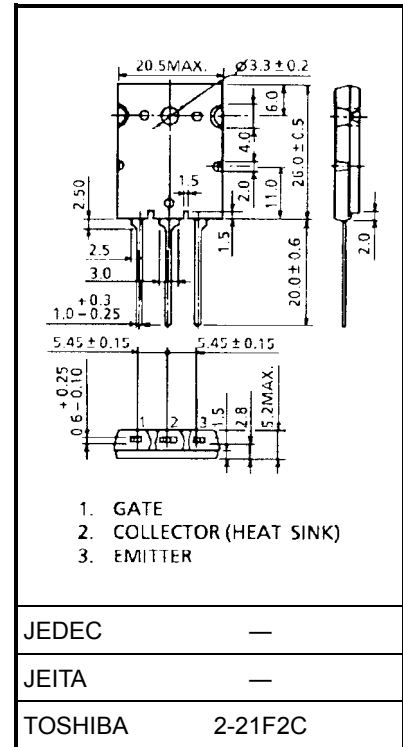

JEDEC	—
JEITA	—
TOSHIBA	2-21F2C

Weight: 9.75 g (typ.)

Equivalent Circuit

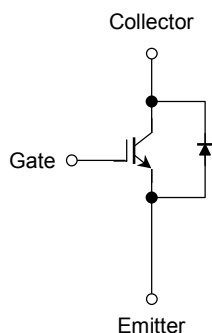

Electrical Characteristics (Ta = 25°C)

Characteristic		Symbol	Test Condition	Min	Typ.	Max	Unit
Gate Leakage Current		I_{GES}	$V_{GE} = \pm 25 \text{ V}, V_{CE} = 0$	—	—	± 500	nA
Collector Cut-off Current		I_{CES}	$V_{CE} = 1000 \text{ V}, V_{GE} = 0$	—	—	1.0	mA
Gate-Emitter Cut-off Voltage		$V_{GE} \text{ (OFF)}$	$I_C = 60 \text{ mA}, V_{CE} = 5 \text{ V}$	3.0	—	6.0	V
Collector-Emitter Saturation Voltage		$V_{CE} \text{ (sat) (1)}$	$I_C = 10 \text{ A}, V_{GE} = 15 \text{ V}$	—	1.6	2.3	V
Collector-Emitter Saturation Voltage		$V_{CE} \text{ (sat) (2)}$	$I_C = 60 \text{ A}, V_{GE} = 15 \text{ V}$	—	2.3	2.8	V
Input Capacitance		C_{ies}	$V_{CE} = 10 \text{ V}, V_{GE} = 0, f = 1 \text{ MHz}$	—	4000	—	pF
Switching Time	Rise Time	t_r		—	0.23	—	μs
	Turn-on Time	t_{on}		—	0.33	—	
	Fall Time	t_f		—	0.25	0.40	
	Turn-off Time	t_{off}		—	0.70	—	
Emitter-Collector Forward Voltage		V_{ECF}	$I_{EC} = 15 \text{ A}, V_{GE} = 0$	—	1.5	2.0	V
Reverse Recovery Time		t_{rr}	$I_F = 15 \text{ A}, V_{GE} = 0, di/dt = -20 \text{ A}/\mu\text{s}$	—	0.8	2.5	μs
Thermal Resistance		$R_{th(j-c)}$	—	—	—	0.74	°C/W
Thermal Resistance		$R_{th(j-c)}$	—	—	—	4.0	°C/W

