

LOC	DIST	P	F	ZONE	LTR	DESCRIPTION	DATE	APPD
AG	53				C	REVISED PER 0030-0159-96	5-17-95	RT

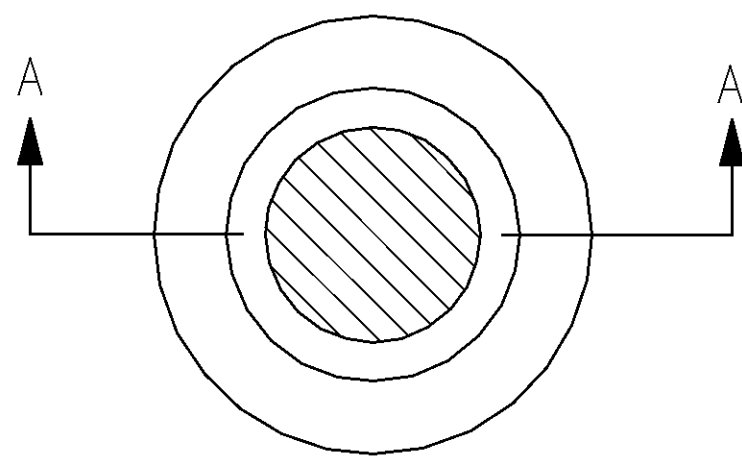

- 1. PLATING: SPRING; GOLD, 0.00076 [.000030] THK MIN PER MIL-G-45204, TYPE II. EYELET; TIN 0.00254 [.000100] THK MIN PER MIL-T-10727.
- 2. RECOMMENDED HOLE SIZES PLATED OR UNPLATED: MACHINE INSERTION; 2.62±0.08 [.103±.003].
- 3. TO INSURE PROPER SPRING TENSION DO NOT EXCEED A 0.05 [.002] DIFFERENCE IN PIN DIA WHEN CHANGING TO A SMALLER PIN.
- 4. RECOMMENDED PIN DIA 1.47-1.57 [.058-.062].

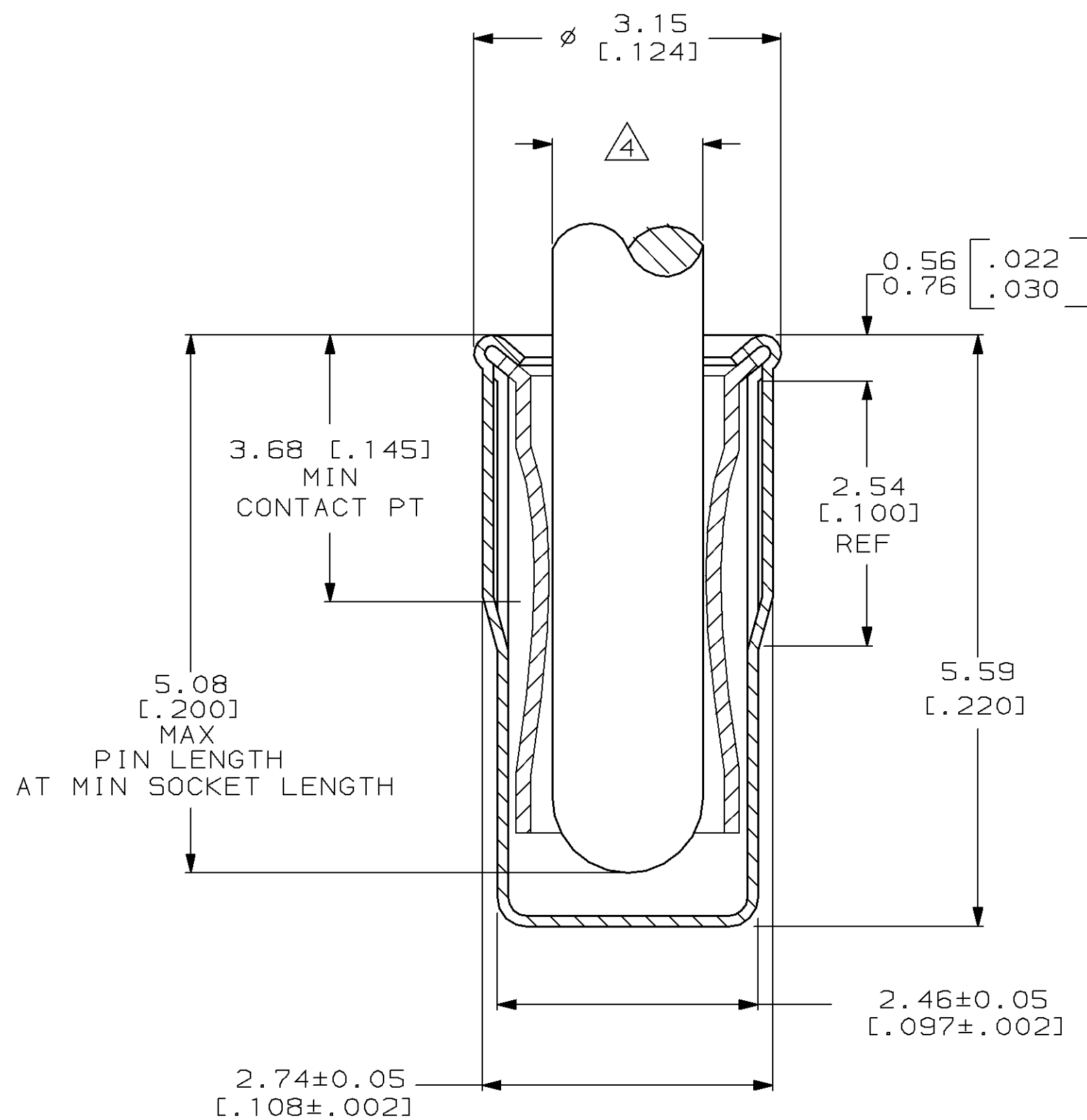

SECTION A-A

645512-1 AS SHOWN

DO NOT SCALE PRINT. UNLESS SPECIFIED DIMENSIONS IN mm [INCHES]		PART NO	
TOLERANCES ON :	DR K.SALMON 4-18-90	AMP Incorporated Harrisburg, PA 17105-3608	
2 PLC DEC ± -	CHK - R.MILLER 4-18-90		
3 PLC DEC ± 0.20 [.008]	APPD - F.BOYD 4-18-90	NAME ASSEMBLY, SOCKET, SPRING, MINIATURE SERIES 5	
ANGLES ± -	APPD -		
MATERIAL SPRING; BERYLLIUM COPPER QQ-C-533	APPD -	SIZE C 00779	DRAWING NO 645512
EYELET; COPPER QQ-C-576	PRODUCT SPEC -	SCALE 20:1	SHEET 10F1
FINISH	APPLICATION SPEC -		
	WEIGHT -		

Mouser Electronics

Authorized Distributor

Click to View Pricing, Inventory, Delivery & Lifecycle Information:

[TE Connectivity:](#)

[645512-1](#)