

Features

- $V_{DS} (V) = -30V$
- $R_{DS(ON)} < 58m\Omega$ ($V_{GS} = -10V$)
- $R_{DS(ON)} < 98m\Omega$ ($V_{GS} = -4.5V$)
- Generation V Technology
- Ultra Low On-Resistance
- Surface Mount
- Fully Avalanche Rated
- Lead-Free

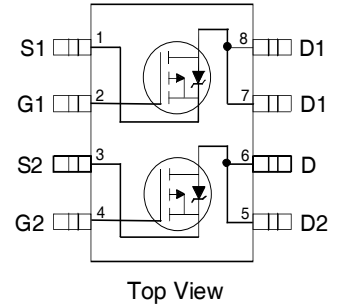

Description

The SOP-8 has been modified through a customized eadrame for enhanced thermacharacterstics and multiple die capability making it ideal in a variety of power applications. With these improvements, multiple devices can be used in an application with dramatically reduced board space. The package is desianed forn vapor phase, infra red, or wave soldering techniques

Absolute Maximum Ratings ($T_A = 25^\circ C$ Unless Otherwise Noted)

	Symbol	Maximum	Units
Drain-Source Voltage	V_{DS}	-30	V
Gate-Source Voltage	V_{GS}	± 20	
Continuous Drain Current ^⑤	I_D	$T_A = 25^\circ C$	-4.9
		$T_A = 70^\circ C$	-3.9
Pulsed Drain Current	I_{DM}	-30	A
Continuous Source Current (Diode Conduction)	I_S	-2.5	
Maximum Power Dissipation ^⑤	P_D	$T_A = 25^\circ C$	2.0
		$T_A = 70^\circ C$	1.3
Single Pulse Avalanche Energy	E_{AS}	140	mJ
Avalanche Current	I_{AR}	-2.8	A
Repetitive Avalanche Energy	E_{AR}	0.20	mJ
Peak Diode Recovery dv/dt ^③	dv/dt	-5.0	V/ ns
Junction and Storage Temperature Range	T_J, T_{STG}	-55 to + 150	$^\circ C$

Thermal Resistance Ratings

Parameter	Symbol	Limit	Units
Maximum Junction-to-Ambient ^⑤	$R_{\theta JA}$	62.5	$^\circ C/W$

Electrical Characteristics @ T_J = 25°C (unless otherwise specified)

	Parameter	Min.	Typ.	Max.	Units	Conditions
V _{(BR)DSS}	Drain-to-Source Breakdown Voltage	-30			V	V _{GS} = 0V, I _D = -250μA
ΔV _{(BR)DSS} /ΔT _J	Breakdown Voltage Temp. Coefficient		0.022		V/°C	Reference to 25°C, I _D = -1mA
R _{DS(on)}	Static Drain-to-Source On-Resistance		42	60	mΩ	V _{GS} = -10V, I _D = -4.9A ④
			77	100		V _{GS} = -4.5V, I _D = -3.6A ④
V _{GS(th)}	Gate Threshold Voltage	-1.0			V	V _{DS} = V _{GS} , I _D = -250μA
g _{fs}	Forward Transconductance		7.7		S	V _{DS} = -15V, I _D = -4.9A
I _{DSS}	Drain-to-Source Leakage Current			-1.0	μA	V _{DS} = -24V, V _{GS} = 0V
				-25		V _{DS} = -24V, V _{GS} = 0V, T _J = 55°C
I _{GSS}	Gate-to-Source Forward Leakage			100	nA	V _{GS} = -20V
	Gate-to-Source Reverse Leakage			-100		V _{GS} = 20V
Q _g	Total Gate Charge		23	34	nC	I _D = -4.9A
Q _{gs}	Gate-to-Source Charge		3.8	5.7		V _{DS} = -15V
Q _{gd}	Gate-to-Drain ("Miller") Charge		5.9	8.9		V _{GS} = -10V, See Fig. 10 ④
t _{d(on)}	Turn-On Delay Time		13	19	ns	V _{DD} = -15V
t _r	Rise Time		13	20		I _D = -1.0A
t _{d(off)}	Turn-Off Delay Time		34	51		R _G = 6.0Ω
t _f	Fall Time		32	48		R _D = 15Ω ④
C _{iss}	Input Capacitance		710		pF	V _{GS} = 0V
C _{oss}	Output Capacitance		380			V _{DS} = -25V
C _{rss}	Reverse Transfer Capacitance		180			f = 1.0MHz, See Fig. 5

Source-Drain Ratings and Characteristics

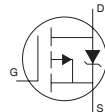
	Parameter	Min.	Typ.	Max.	Units	Conditions
I _S	Continuous Source Current (Body Diode)			-2.5	A	MOSFET symbol showing the integral reverse p-n junction diode. 
I _{SM}	Pulsed Source Current (Body Diode) ①			-30		
V _{SD}	Diode Forward Voltage	-0.78	-1.0		V	T _J = 25°C, I _S = -1.7A, V _{GS} = 0V ③
t _{rr}	Reverse Recovery Time		44	66	ns	T _J = 25°C, I _F = -1.7A
Q _{rr}	Reverse Recovery Charge		42	63	nC	di/dt = 100A/μs ③

Notes:

- ① Repetitive rating; pulse width limited by max. junction temperature. (See fig. 11)
- ② Starting T_J = 25°C, L = 35mH
R_G = 25Ω, I_{AS} = -2.8A.
- ③ I_{SD} ≤ -2.8A, di/dt ≤ 150A/μs, V_{DD} ≤ V_{(BR)DSS},
T_J ≤ 150°C
- ④ Pulse width ≤ 300μs; duty cycle ≤ 2%.
- ⑤ Surface mounted on FR-4 board, t ≤ 10sec.

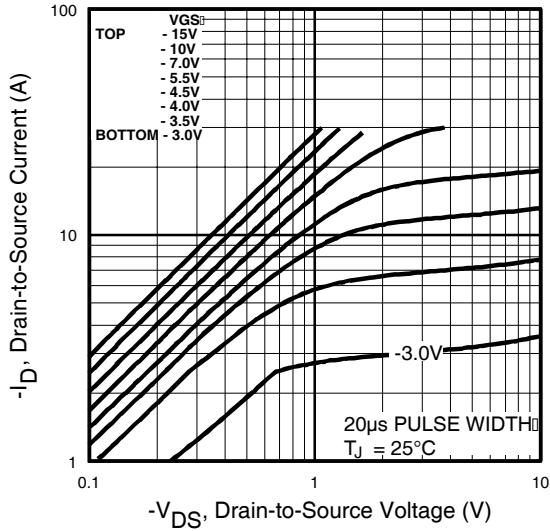

Fig 1. Typical Output Characteristics

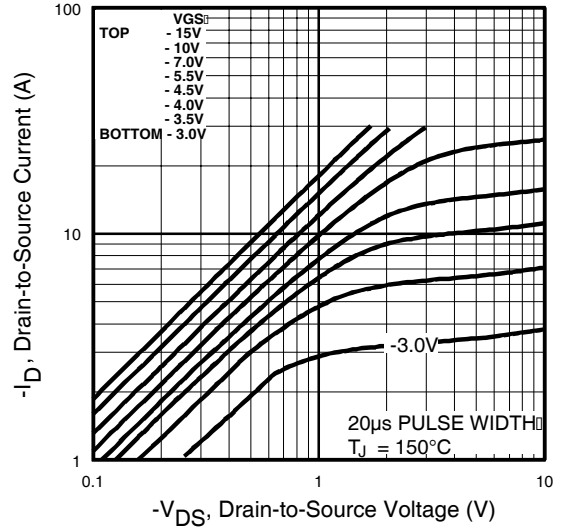

Fig 2. Typical Output Characteristics

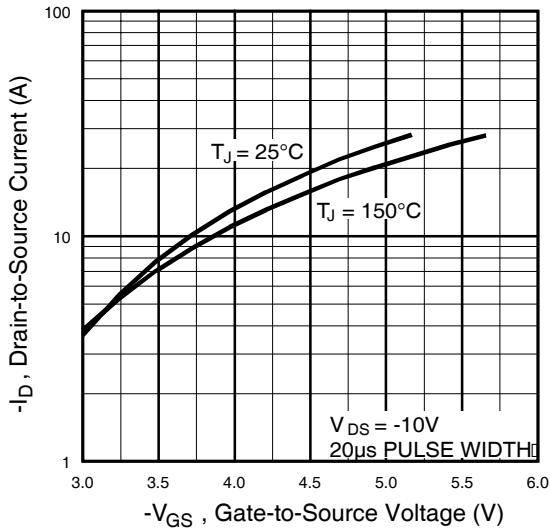

Fig 3. Typical Transfer Characteristics

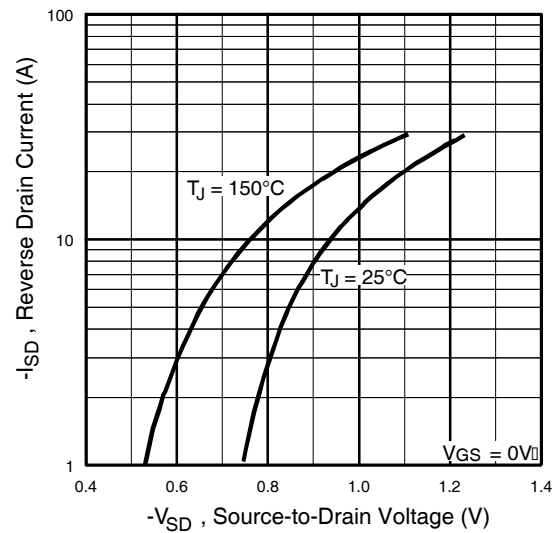

Fig 4. Typical Source-Drain Diode Forward Voltage

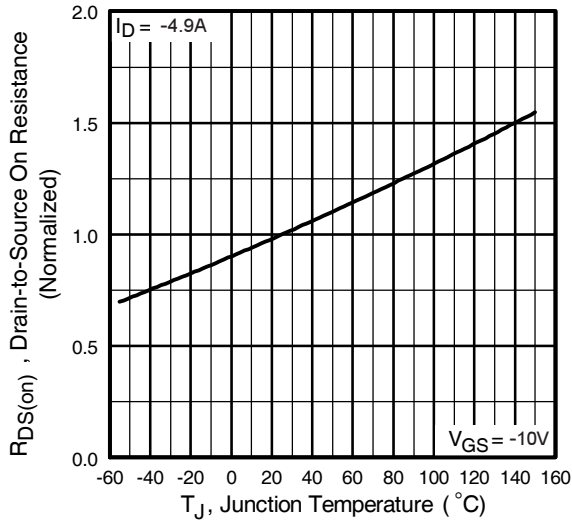

Fig 5. Normalized On-Resistance Vs. Temperature

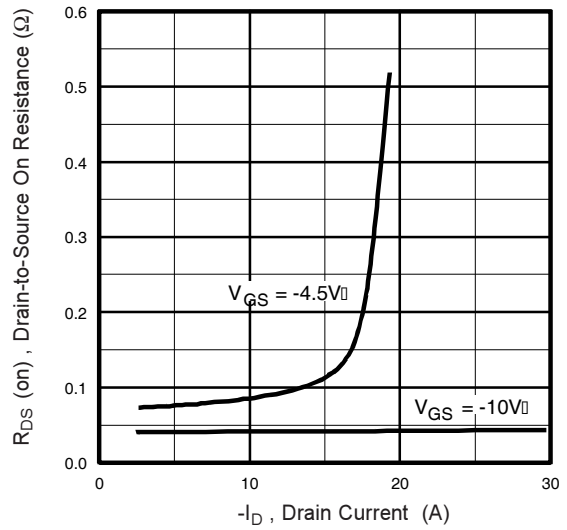

Fig 6. Typical On-Resistance Vs. Drain Current

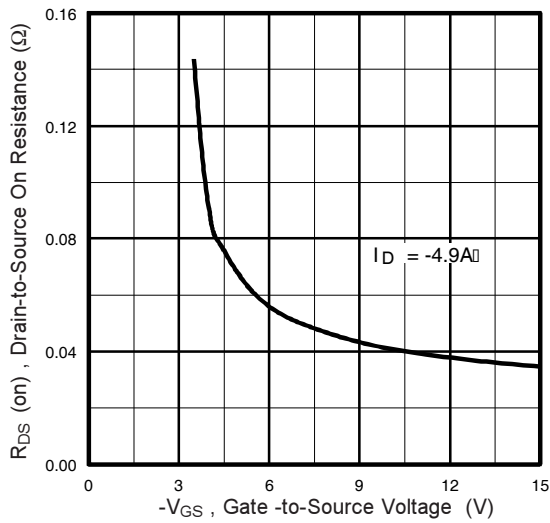

Fig 7. Typical On-Resistance Vs. Gate Voltage

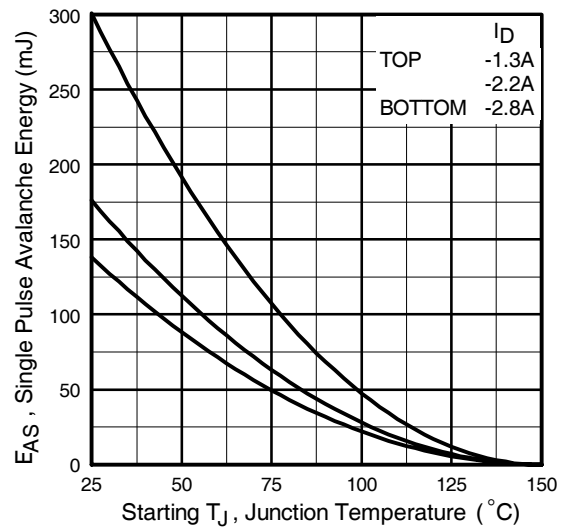

Fig 8. Maximum Avalanche Energy Vs. Drain Current

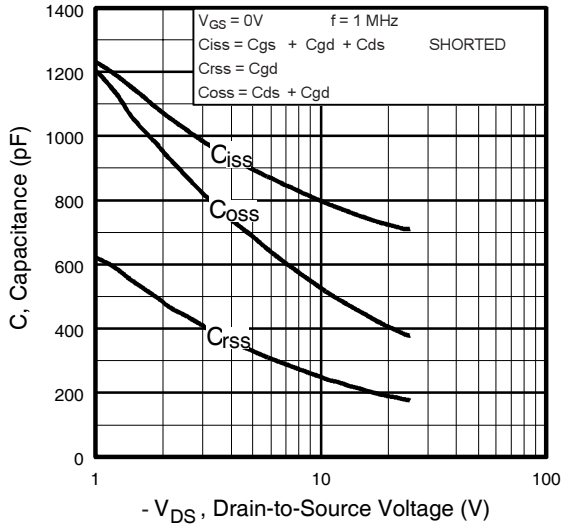

Fig 9. Typical Capacitance Vs. Drain-to-Source Voltage

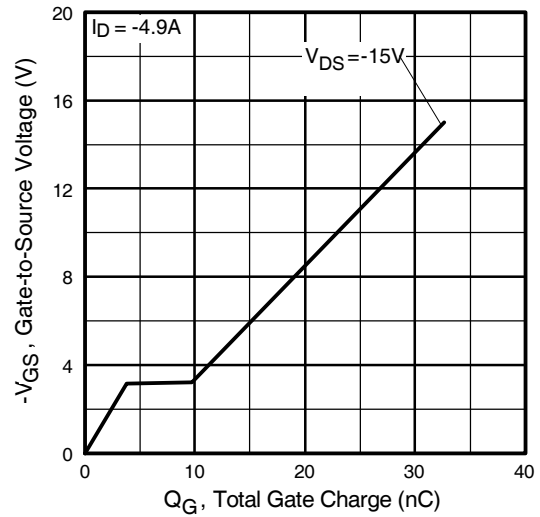

Fig 10. Typical Gate Charge Vs. Gate-to-Source Voltage

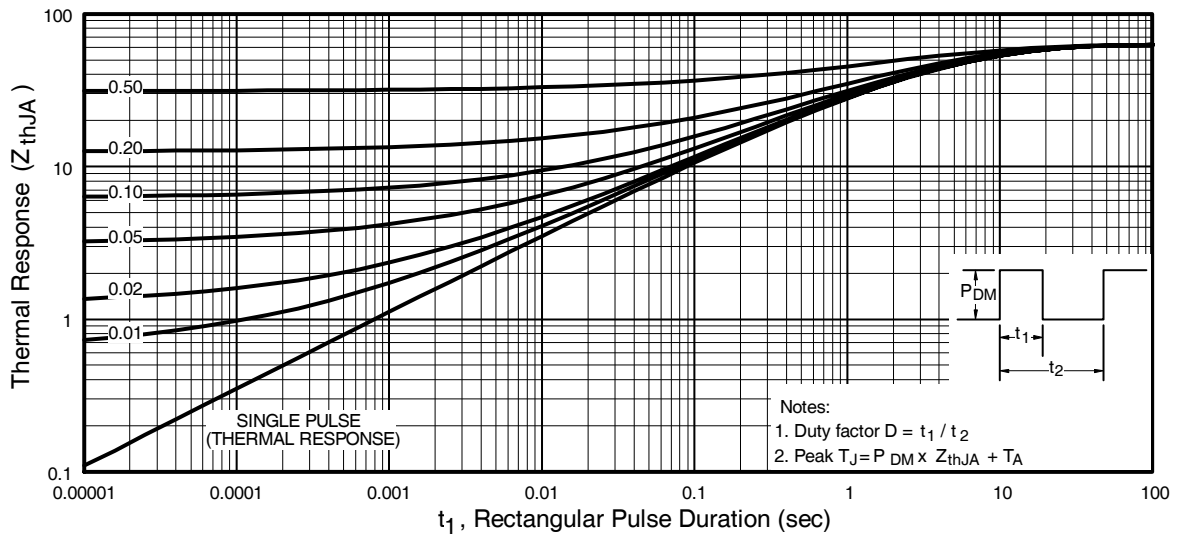
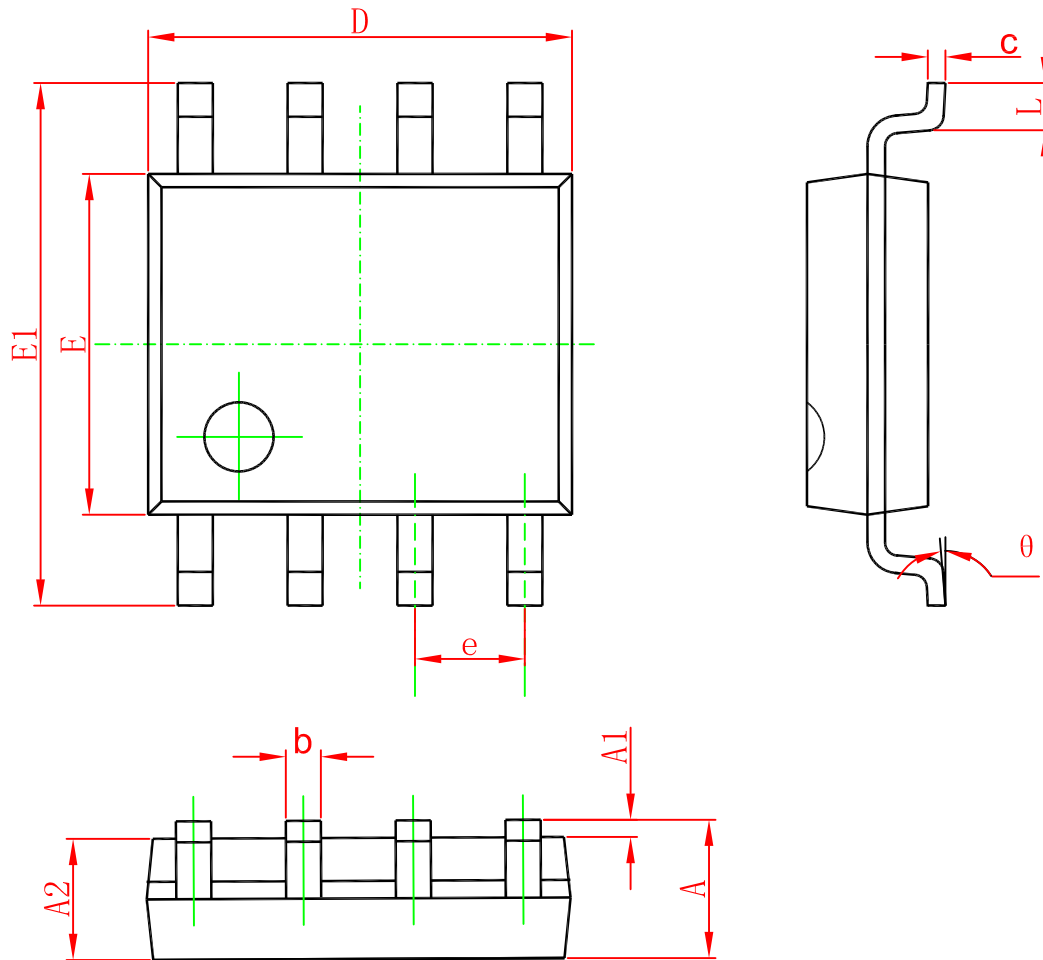

Fig 11. Maximum Effective Transient Thermal Impedance, Junction-to-Ambient

SOP-8



Symbol	Dimensions In Millimeters		Dimensions In Inches	
	Min	Max	Min	Max
A	1.350	1.750	0.053	0.069
A1	0.100	0.250	0.004	0.010
A2	1.350	1.550	0.053	0.061
b	0.330	0.510	0.013	0.020
c	0.170	0.250	0.006	0.010
D	4.700	5.100	0.185	0.200
E	3.800	4.000	0.150	0.157
E1	5.800	6.200	0.228	0.244
e	1.270(BSC)		0.050(BSC)	
L	0.400	1.270	0.016	0.050
θ	0°	8°	0°	8°

Marking

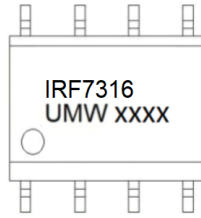

Ordering information

Order code	Package	Baseqty	Deliverymode
UMW IRF7316TR	SOP-8	3000	Tape and reel