

Flow Sensor

FR06

Version : 1.1

Issue Date: 2022.02.16

Zhengzhou Winsen Electronic Technology Co., Ltd

Statement

This manual copyright belongs to Zhengzhou Winsen Electronics Technology Co., LTD. Without the written permission, any part of this manual shall not be copied, translated, stored in database or retrieval system, also can't spread through electronic, copying, record ways.

Thanks for purchasing our product. In order to let customers use it better and reduce the faults caused by misuse, please read the manual carefully and operate it correctly in accordance with the instructions. If users disobey the terms or remove, disassemble, change the components inside of the sensor, we shall not be responsible for the loss.

The specific such as color, appearance, sizes &etc, please in kind prevail.

We are devoting ourselves to products development and technical innovation, so we reserve the right to improve the products without notice. Please confirm it is the valid version before using this manual. At the same time, users' comments on optimized using way are welcome.

Please keep the manual properly, in order to get help if you have questions during the usage in the future.

Zhengzhou Winsen Electronics Technology CO., LTD

1.Profile:

FR06 flow sensor is an upgrading developed from F1022 . It adopts MEMS Thermal principle to monitor the flow of pipeline gas medium. This product adopts low pressure loss design and is widely used for all kinds of gas measurement.

2. Features:

- ✧ High sensitivity;
- ✧ Very low pickup flow;
- ✧ High Accuracy;
- ✧ Low voltage loss;
- ✧ Modular design;
- ✧ High measurement repeatability;
- ✧ Suitable for customization of various products

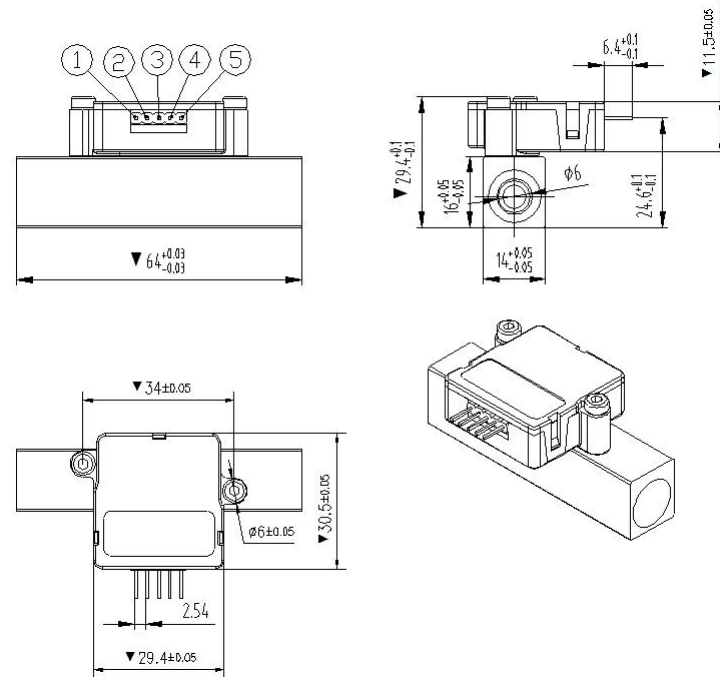

3.Technical Parameters:

3.1Structure Parameters

3.2Electrical Index

Model No.	FR06
Full Scale(SLM)	10/20 SLM
Drift diameter	DN6
Output Mode	Linearity 0.5V ~ 4.5V(Optional)
Output impedance	200Ω
Working Voltage	DC5V ~ 14V
Working Current	≤10mA
Accuracy	±(2+0.5FS)%

Repeatability	0.50%				
Output Drift	0.12%/°C				
△Pmax	≤600Pa				
Working Pressure	Customized				
Working Temperature	0°C ~ 50°C				
Storage Temperature	-20°C ~ 80°C				
Measurement Medium	Dry and clean non-corrosive gas				
Electrical interface	2.54mm-5P PIN or PH2.0-5P Terminal (Optional)				
Mechanical Interface	G1/8				
Calibration mode	Air Calibration (20°C、101.325kPa)				
PIN Definition	①	②	③	④	⑤
			GND	VCC	OUT

3.2 Calibration

The flow sensor of our company adopts standard condition and air calibration by default. If the user has special requirements, calibrate according to the customer's requirements.

3.2.1 Standard Condition:

Temperature :0°C, Air Pressure: 101.325kPa
SCCM: Standard mL/min SLM: Standard L/min

3.2.2 Manufacture Environment:

Manufactured and calibrated in environment with temperature of

22±2°C,Purify and (30% ~ 35%) RH.

4.Naming Rules

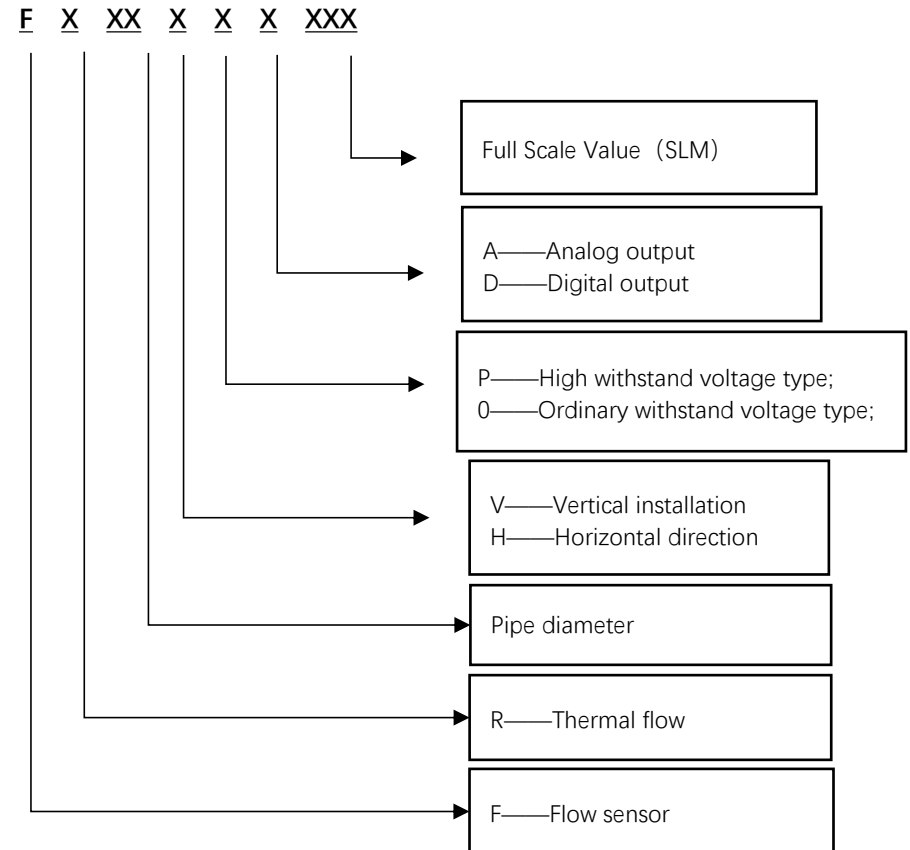

5. Output Calculation

Actual flow=full scale * (sensor actual output voltage-zero output voltage) / (full scale output voltage-zero output voltage)

For example: the sensor full scale is 20 SLM, the sensor zero output voltage is 1V and full scale output voltage is 5V, and the actual output is 2.5V.

$$\text{Then the actual flow} = 20\text{SLM} \times (2.5\text{V} - 1\text{V}) / (5\text{V} - 1\text{V}) = 7.5\text{SLM}$$

6. Cautions

6.1 The gas used must be purified to avoid dust, liquid and oil stain. If necessary, a filtering device can be installed in the gas circuit.

6.2 The medium used must be dry and clean non-corrosive gas.

6.3 The pressure of the medium used shall not exceed 1.2 times of the maximum working pressure of the product.

6.4 In order to ensure the measurement accuracy of the sensor, it is recommended to install a straight pipe section at least 5 times the nominal diameter at the inlet of the sensor and at least 3 times the nominal diameter at the outlet.

7. Fault Diagnosis

7.1 Preliminary inspection

7.1.1 Check the opening of air source and inlet.

7.1.2 Ensure the correct connection of communication lines.

7.1.3 Check whether the medium pressure and ambient temperature meet the product technical indicators.

7.2 Fault Check

No.	Symptoms	Possible Causes	Solutions
1	No signal output in case of no ventilation	Sensor damage	Return for Maintenance
	Output 10-12v without ventilation	Reverse terminal	Check whether the terminal is inserted

		insertion	correctly
2	Without ventilation, the output deviation at zero point exceeds the maximum tolerance	Zero Point Drift	Zero Point Calibration/ Return for Maintenance
3	No signal output during ventilation	Reversed air inlet installation	Replace the installation direction
		Sensor damage	Return for maintenance
4	Flow out of tolerance during ventilation	Output Drift	Return for maintenance
		Incorrect reference standard	Use mass flow method or higher accuracy flow meters for testing

8. Disclaimer

Our company is not responsible for the damage caused by the following circumstances:

- Natural disasters.
- Misoperation or unreasonable use.
- Operate or store in unsuitable or harsh environment.
- Unauthorized modification or disassembly of products.
- Violent means lead to product damage.

9. Appendix

Target gas flow = Sensor Reading Value × Conversion coefficient

Target Gas	Code (SEMI52-0302)	Specific Heat (calorie/gram°C)	Density (gram/L0°C)	Conversion coefficient
He	001	1.242	0.179	1.420
Ne	002	0.246	0.900	1.431
Ar	004	0.125	1.784	1.420
Xe	006	0.038	5.858	1.431
H ₂	007	3.422	0.090	1.010

Air	008	0.240	1.293	1.001	C ₄ H ₁₀	117	0.404	2.650	0.261
CO	009	0.249	1.250	1.000	C ₂ H ₆	136	0.340	2.055	0.392
HBr	010	0.086	3.610	0.999	CH ₃ O	176	0.328	1.430	0.584
HCl	011	0.191	1.627	0.988	C ₅ H ₁₂	240	0.392	3.219	0.217
HF	012	0.348	0.893	1.001					
N ₂	013	0.249	1.25	1.000					
O ₂	015	0.220	1.427	0.981					
NO	016	0.238	1.339	0.978					
F ₂	018	0.197	1.695	0.931					
Cl ₂	019	0.115	3.163	0.858					
H ₂ S	022	0.228	1.520	0.802					
CO ₂	025	0.202	1.964	0.739					
NO ₂	026	0.192	2.052	0.737					
CH ₄	028	0.532	0.715	0.722					
NH ₃	029	0.501	0.760	0.719					
SO ₂	032	0.149	2.858	0.687					
AsH ₃	035	0.117	3.478	0.673					
C ₂ H ₄	038	0.366	1.251	0.597					
C ₂ H ₂	042	0.405	1.162	0.596					
BF ₃	048	0.178	3.025	0.508					
C ₂ H ₆	054	0.424	1.342	0.482					
B ₂ H ₆	058	0.502	1.235	0.441					
CF ₄	063	0.166	3.964	0.420					
C ₃ H ₄	068	0.363	1.787	0.421					
C ₃ H ₆	069	0.366	1.877	0.411					
C ₃ H ₈	089	0.399	1.967	0.358					
C ₄ H ₆	093	0.352	2.413	0.322					
CCl ₄	101	0.130	6.860	0.306					
C ₄ H ₈	104	0.372	2.503	0.299					