



Intelligent Infrared Carbon Dioxide Module (Model: MH-Z14A)

User's Manual

Zhengzhou Winsen Electronics Technology CO., LTD.

Statement

The copyright of this manual belongs to Zhengzhou Winsen Electronics Technology Co., LTD.

Without the written permission, any part of this manual shall not be copied, translated, stored in database or retrieval system, also can't spread through electronic, copying, record ways.

Thanks for purchasing our product. In order to enable customers to better use the product and reduce the faults caused by misuse, please read the manual carefully and operate it correctly in accordance with the instructions. If users disobey the terms or remove, disassemble, change the components inside of the sensor, we shall not be responsible for the loss.

The specific such as color, appearance, sizes ...etc., please in kind prevail.

We are devoting ourselves to products development and technical innovation, so we reserve the right to improve the products without notice. Please confirm it is the valid version before using this manual. At the same time, users' comments on optimized using way are welcome.

Please keep the manual properly, in order to get help if you have questions during the usage in the future.

Zhengzhou Winsen Electronics Technology CO., LTD

MH-Z14A NDIR CO2 Module

1. Profile

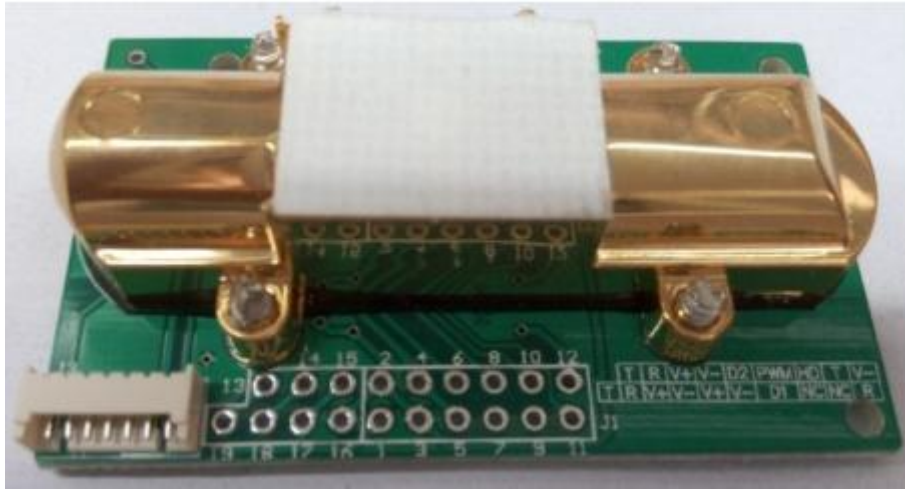

MH-Z14A NDIR Infrared gas module is a common type, small size sensor, using non-dispersive infrared (NDIR) principle to detect the existence of CO₂ in the air, with good selectivity, non-oxygen dependent and long life. Built-in temperature sensor can do temperature compensation; and it has digital output and analog voltage output. This common type infrared gas sensor is developed by the tight integration of mature infrared absorbing gas detection technology, Precision optical circuit design and superior circuit design.

Its design, production and inspection adhere to below: *GB/T13384-92*

2. Applications:

MH-Z14A NDIR Infrared gas module is applied in the HVAC, indoor air quality monitoring, industrial process, safety and protection monitoring, agriculture and animal husbandry production process monitoring.

3. Main functions and features:

- Gold-plated chamber, waterproof & anti-corrosion treatment
- High sensitivity, High resolution
- Good stability
- Temperature compensation, excellent linear output
- Output modes: UART, analog voltage signal, PWM wave
- Long lifespan
- Anti-water vapor interference
- No poisoning

4. Main technical parameters

Working voltage	4.5 V ~ 5.5V DC
Average current	< 60 mA(@5V input)
Peak current	150 mA(@5V input)
Interface level	3.3 V (5V compatible)
Measuring range	0~10000ppm optional(refer to table 2)
Output signal	Serial port(UART, TTL LEVEL)
	PWM
	Analog output(DAV)0.4-2V DC
Preheat time	3min
Response Time	$T_{90} < 120s$
Working temperature	0°C ~ 50°C
Working humidity	0~90%RH(no condensation)
Weight	15 g
Lifespan	>5 year

Common-used range and precision:

Target Gas	Measuring Range	Accuracy
Carbon Dioxide (CO2)	0~2000ppm	$\pm (50ppm+3\%$ reading value)
	0~5000ppm	
	0~10000ppm	$\pm 10\%$ reading value

5. Structure

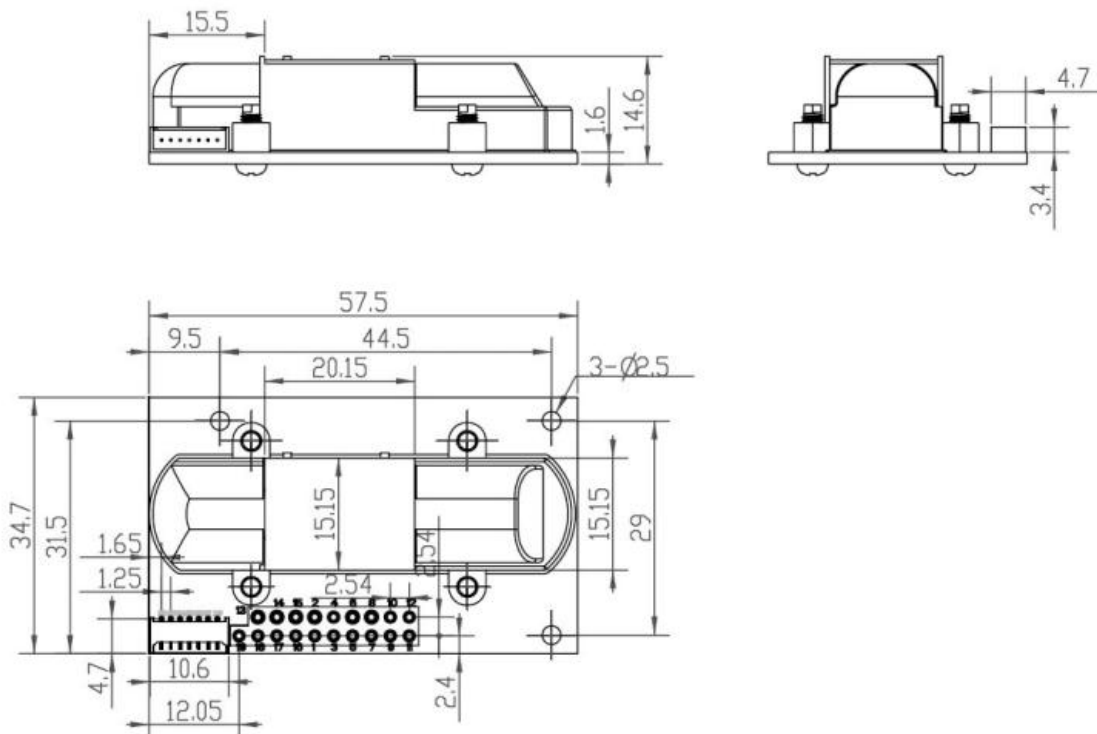

6. Definition for pins

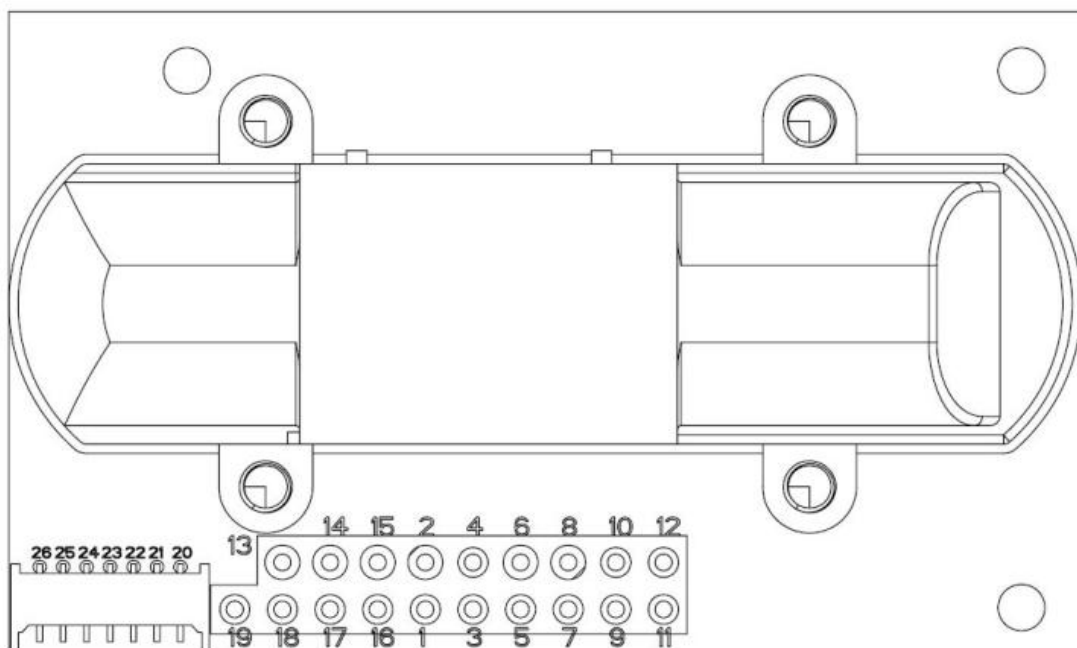

PIN	Description
Pad1/Pad15/Pad17/pad23	Vin voltage input
Pad2/Pad3/ Pad12/Pad16/pad22	GND
Pad4/pad21	Analog ouput (0.4~2V)
Pad6/pad26	PWM
Pad8/pad20	HD (zero calibration, low level for more than 7 seconds valid)
Pad7/Pad9	NC
Pad11/Pad14/Pad18/pad24	UART (RXD) TTL level input
Pad10/Pad13/Pad19/pad25	UART (TXD) TTL level output

Output mode

PWM	
For example the detect range is 0-2000ppm	
CO2 detect range	0-2000ppm
Period	1004ms ± 5%
Initial segment of period high level output	2ms(theoretical value)
calculation formula through PWM to CO2 concentration value	$C_{ppm} = 2000 \times (T_H - 2ms) / (T_H + T_L - 4ms)$
<p>C_{ppm} means CO2 concentration value through calculation, units is ppm</p> <p>T_H is time for high level during an output cycle</p> <p>T_L is time for low level during an output cycle.</p>	

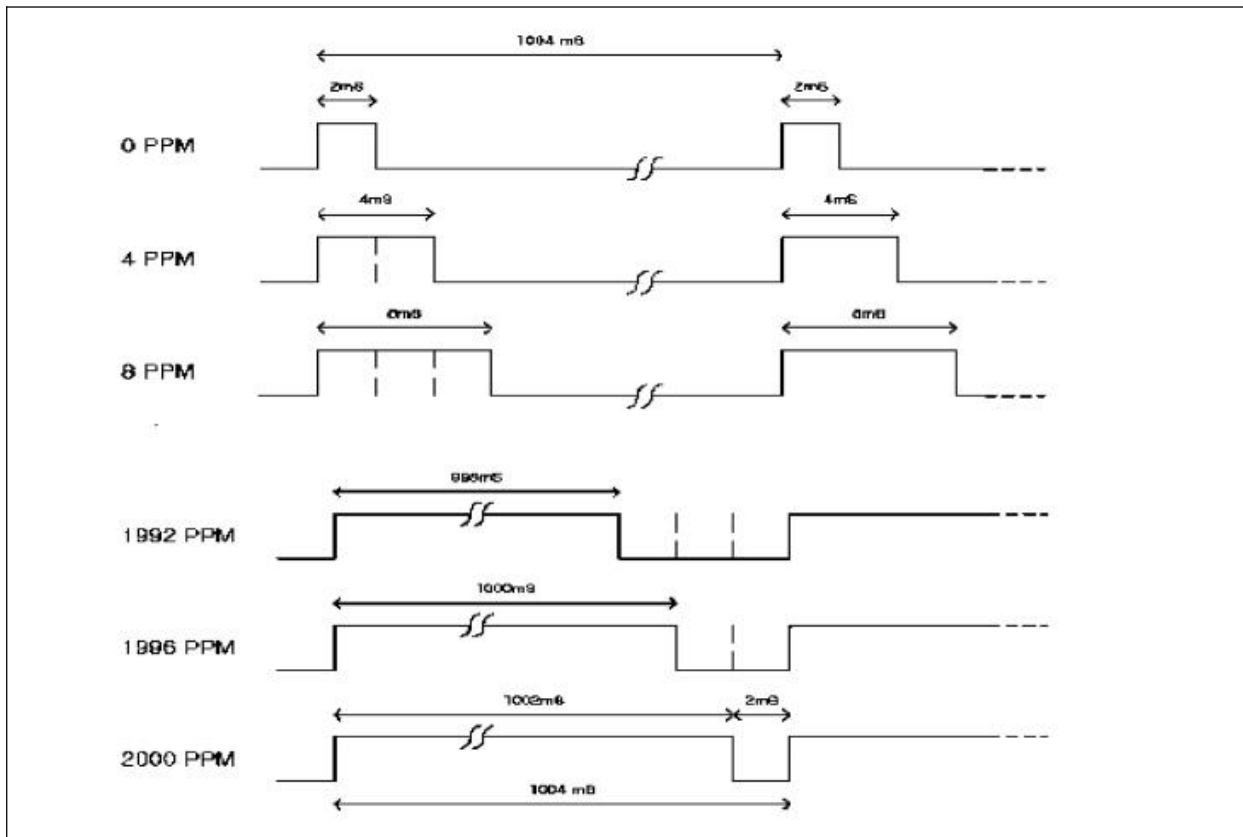

UART output

Hardware connection

Contacting sensor's Vin-GND-RXD-TXD to 5V-GND-TXD-RXD of the user.(Users must use TTL electrical level, if using RS232, must be switched)

Software setting

The serial port baud rate must be 9600, setting the data bits to 8, stop bit to 1, no parity value

0x86	Gas concentration
0x87	Calibrate zero point value (ZERO)
0x88	Calibrate span point value (SPAN)
0x79	Start/stop auto-calibration function of zero point value
0x99	Setting detect range

0x86 read gas concentration								
Send command								
Byte0	Byte1	Byte2	Byte3	Byte4	Byte5	Byte6	Byte7	Byte8
Starting byte	Sensor No.	command	-	-	-	-	-	Check value
0xFF	0x01	0x86	0x00	0x00	0x00	0x00	0x00	0x79
Returned value								
Byte0	Byte1	Byte2	Byte3	Byte4	Byte5	Byte6	Byte7	Byte8
Starting byte	Sensor No.	High 8 bit concentration	Low 8 bit concentration	-	-	-	-	CRC
0xFF	0x01	HIHG	HOW					CRC
Gas concentration=high*256+low								

0x87-zero point value calibration command								
Send command								
Byte0	Byte1	Byte2	Byte3	Byte4	Byte5	Byte6	Byte7	Byte8
Starting byte	Sensor No.	command	-	-	-	-	-	CRC
0XFF	0x01	0x87	0x00	0x00	0x00	0x00	0x00	CRC
No return value Note: zero point value is 400ppm, before sending the zero point calibration command, pls make sure the sensor running on the environment below 400ppm at least 20 mins								

0x88-SPAN point value calibration command								
Send command								
Byte0	Byte1	Byte2	Byte3	Byte4	Byte5	Byte6	Byte7	Byte8
Starting byte	Sensor No.	command	High 8 bit SPAN-	Low 8 bit SPAN	-	-	-	CRC
0XFF	0x01	0x88	HIGH	LOW	0x00	0x00	0x00	CRC
No return value e.g. if SPAN value is 2000ppm, so high=2000/256, low=2000%256 Note: before sending SPAN command, pls make sure the sensor running in that CO2 concentration at least 20 mins We suggestion used 2000ppm to be the SPAN value, if need lower value to be the SPAN value, pls choose the value more than 1000ppm								

0x79-start/stop auto-calibration function								
Send command								
Byte0	Byte1	Byte2	Byte3	Byte4	Byte5	Byte6	Byte7	Byte8
Starting byte	Sensor No.	command			-	-	-	CRC
0XFF	0x01	0x79	0xA0/0x00	0x00	0x00	0x00	0x00	CRC
No return value Note: Byte3 IS 0xA0 means start open auto-calibration function, byte3 is 0x00 means stop the auto calibration function Before shipment, the default is auto-calibration function is open.								

0x99-setting the detect range								
Send command								
Byte0	Byte1	Byte2	Byte3	Byte4	Byte5	Byte6	Byte7	Byte8
Starting byte	Sensor No.	command	Detect range high 8 bit	Detect range low 8 bit	-	-	-	CRC
0XFF	0x01	0x99	high	low	0x00	0x00	0x00	CRC
No return value Note: detect range must choose form 2000,5000 and 10000 Detect range high 8 bit=detect range/256, detect range low 8 bit=detect range%256								

Calibration and calculation method								
CRC=(negation(Byte1+ Byte2+ Byte3+ Byte4+ Byte5+ Byte6+ Byte7))+1								
Byte0	Byte1	Byte2	Byte3	Byte4	Byte5	Byte6	Byte7	Byte8
Starting byte	Sensor No.	command	-	-	--	--	--	CRC
0XFF	0x01	0x86	0x00	0x00	0x00	0x00	0x00	CRC
Calculation method 1. Plus form byte 1 to byte7:0x01+0x86+0x00+0x00+0x00+0x00+0x00=0x87 2. Negation:0Xff-0x87=0x78 3. Negation plus 1: 0x78+0x01=0x79								
C programming language								
<pre> char getChecksum(char *packet) { char i, checksum; for(i = 1; i < 8; i++) { checksum += packet[i]; } checksum = 0xff – checksum; checksum += 1; return checksum; } </pre>								

Zero point value calibration function

The sensor has 3 methods to do zero point value calibration : calibration by hand, calibration by command and auto calibration function. Zero point value calibration means calibration 400ppm.

Calibration zero point value by hands

If do zero point value calibration by hands, please contact sensor's HD pins input low level(0V), and need last form 7 seconds, make sure the sensor running on the environment below 400ppm at least 20 mins

Calibration by command (please refer to the UART command for zero point value)

Auto-calibration function

Auto-calibration function means, after the sensor running in the working place for period, it can do the zero point value calibration by itself, the period is form the power one, every 24 hour, it will do once calibration, the value is 400ppm.

This function only suitable for office and living room, does not suitable form greenhouse room, farm and refrigerator house, if used is upper place, please close this function. If close function, please do zero point value calibration terminally, if necessary, please do it by hands or by command.

Note

1. Please avoid the pressure of its gilded plastic chamber from any direction, during welding, installation, and use.
- 2 When placed in small space, the space should be well ventilated, especially for diffusion window.
- 3 The sensor should be away from heat, and avoid direct sunlight or other heat radiation.
- 4 Do not use the sensor in the high dusty environment for long time.
- 5 To ensure the normal work, the power supply must be among 4.5V~5.5V DC rang, the power current must be not less than 150mA. Out of this range, it will result in the failure of the sensor. (The concentration output is low, or the sensor can not work normally.)
- 6 During the zero point calibration procedure by manual, the sensor must work in stable gas environment (400ppm) for over 20 minutes.
Connect the HD pin to low level (0V) for over 7 seconds

Zhengzhou Winsen Electronics Technology Co., Ltd

Add: No.299, Jinsuo Road, National Hi-Tech Zone,
Zhengzhou 450001 China

Tel: +86-371-67169097/67169670

Fax: +86-371-60932988

E-mail: sales@winsensor.com