

M-series TFT Commands Reference Guide

Clever System

Version 1.3.6

M-series TFT Commands Reference Guide

Update History			
Version	Date	Page	Description
1.0	2014/03/31		First Release(Preliminary Version)
1.0.1	2014/04/10	40	Modify Switch instruction
1.2	2014/09/29	46	1.Modify Erase Level 1 Mode 2.Increase RTP Compensation Mode
1.3	2015/07/06	4,5,7,8,9,10,12,13 47,48	1.Add the instruction table for SPI interface 2.Add the feedback signal for TP
1.3.1	2015/07/08	18~20,22~24,26,28,29,31~33, 35,37,39,40,42,43,45,46 36	1.Modify the reference page number 2.Modify the value of PWM Setting
1.3.2	2015/07/20	3, 12, 13, 19, 23, 27, 30, 32	Modify the name of layer
1.3.3	2015/08/28	13, 19, 23, 27 48	1.Modify the value of Display Layer 2.Add the timing diagram for checking busy
1.3.4	2015/10/01	10 48	1.Modify SPI Mode Instruction Table 2.Modify the timing diagram for checking busy
1.3.5	2016/07/06	49	1. Add INT explanation.
1.3.6	2016/08/24	5	1. Modify Uart Interface (19200.n.8.1)

M-series TFT Commands Reference Guide

Chapter	Contents	Page
1.	General Description	4
2.	Feature	5
3.	Pin Definition	
3.1	Counter Drawing.....	6
3.2	Pin Define	7
4.	Instructions	8
4.1	Text Mode	
4.1.1	Instruction Table	11
4.1.2	Instruction Describe	12
4.2	Graphic Mode	
4.2.1	Instruction Table	17
4.2.2	Instruction Describe	18
4.3	Pixel Mode	
4.3.1	Instruction Table	21
4.3.2	Instruction Describe	22
4.4	Geometric Mode	
4.4.1	Instruction Table	25
4.4.2	Instruction Describe	26
4.5	Erase Mode & Erase Icon Layer Mode	
4.5.1	Instruction Table	30
4.5.2	Instruction Describe	31
4.6	PWM Mode	
4.6.1	Instruction Table	34
4.6.2	Instruction Describe	35
4.7	Power Mode	
4.7.1	Instruction Table	38
4.7.2	Instruction Describe	39
4.8	Backlight Mode	
4.8.1	Instruction Table	41
4.8.2	Instruction Describe	42
4.9	TP Compensation Mode	
4.9.1	Instruction Table	44
4.9.2	Instruction Describe	45
4.10	TP Feedback Signal	47
4.11	ACK	49
4.12	Switch Function	50

M-series TFT Commands Reference Guide

1. General Description

Clever System M-Series TFT is a convenient display module TFT. It can be accomplished protocol by four transmission lines (VCC, GND, TX, RX) and corresponding instruction table. To compare with existing M-Series TFT module, control signal lines and program complexity will be significantly decreased. It will be more convenient for user.

Clever System M-Series TFT has five most modes, include: Text, Graphic, Pixel, Geometric and Clean. The common functions of most modes are following, ex: Repaint display, 180 rotation, Location and Color setting. Besides, each mode has individual function. In Text mode, it has additional functions, ex: Font conversion and Background transparent. In Graphic mode, Clever System M-Series TFT can support max QVGA resolution. In Pixel mode, user can make any pixel of display to color modification. In Geometric mode, it can support drawing line and square. In clean mode, user can clean any block on the display.

Clever System M-Series TFT also has four modes for hardware control, which are PWM, Power, TP and Backlight. In PWM mode, user can control PWM frequency and duty cycle through CN2 Pin10. In Power Mode, sleep mode can be turn on/off by user. In Backlight Mode, user can adjust brightness of module. In TP mode, user can do calibration for touch panel. And last but not least module can provide four GPIO for switch function and Reset function to restart module.

M-series TFT Commands Reference Guide

2. Feature

- Five main modes : Text, Graphic, Pixel, Geometric and Clean.
- Four additional modes : PWM, Power, Backlight and TP
- Operate Voltage : 5V
- **Uart Interface (19200.n.8.1)**
- SPI Interface.
- 24 Bits Full Color
- Four GPIO for Switch.

M-series TFT Commands Reference Guide

3. Pin Definition

3.1 Contour Drawing (For All M-Series)

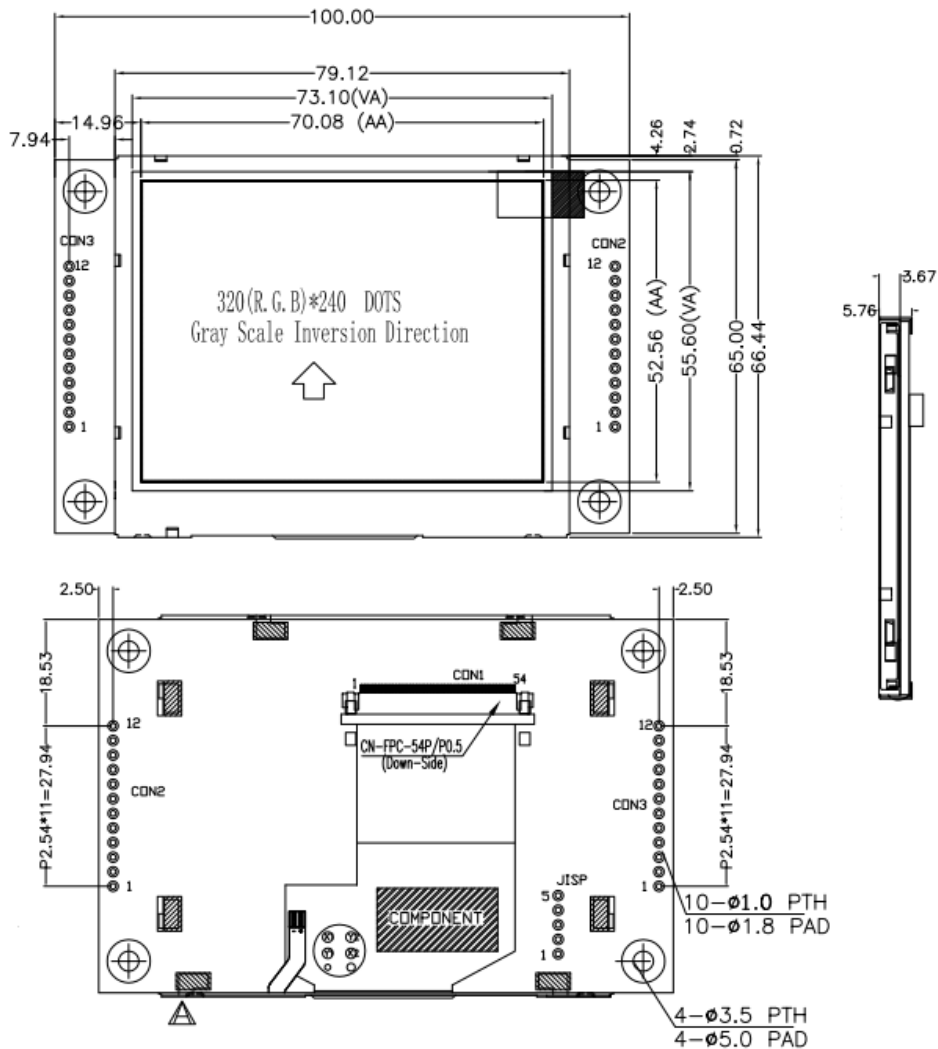

CON2		CON3	
PIN	SYMBOL	PIN	SYMBOL
1	GND	1	GND
2	TX	2	SW1
3	RX	3	SW2
4	VBUS	4	SW3
5	D+	5	SW4
6	D-	6	GND
7	GND	7	SDI
8	RST	8	SDO
9	GND	9	SCK
10	PWM	10	SCS
11	GND	11	INT
12	VBUS	12	VBUS

M-series TFT Commands Reference Guide

3.2 Pin define

CON2		
PIN	SYMBOL	DESCRIPTION
1	GND	0V
2	TX	Transmitter of Uart(TTL)
3	RX	Receiver of Uart(TTL)
4	VBUS	5V
5	D+	USB Data+
6	D-	USB Data-
7	GND	0V
8	RST	Reset
9	GND	0V
10	PWM	PWM Function
11	GND	0V
12	VBUS	5V

CON3		
PIN	SYMBOL	DESCRIPTION
1	GND	0V
2	SW1	Switch 1
3	SW2	Switch 2
4	SW3	Switch 3
5	SW4	Switch 4
6	GND	0V
7	SDI	Serial Data In
8	SDO	Serial Data Out
9	SCK	Serial Clock
10	SCS	Chip Select
11	INT	Serial Interrupt
12	VBUS	5V

M-series TFT Commands Reference Guide

4. Instructions

Clever System M-Series TFT can support nine modes,” Text, Graphic, Pixel, Geometric, Clean, PWM, Power, Backlight and TP“, and instruction table is shown in below respectively. Each mode can be divided three parts, first part is start byte, second part is function setting, and third part is end byte. Corresponding different mode, the second part has individual setting, and more detail is shown in 4.1-4.8.

When user finish correct instruction, the module will send a byte which is called ACK (acknowledgement) to confirm the module receive package. And last but not least Clever System M-Series TFT provides four GPIO for Switch function. The detail for these functions setting are in 4.9 - 4.12.

M-series TFT Commands Reference Guide

UART Mode Instruction Table

a. Text Mode

Instruction of text mode

*only for Uart

1	2	3	4	5	6	7	8	9	10	11	12	13	14	15	16	17	18	19	20	21
SB1	PL	SB2	SB3	MD	WR	TR	XH	XL	YH	YL	SR	SG	SB	BR	BG	BB	SDATA	EB1	EB2	EB3

b. Graphic Mode

Instruction of Graphic mode:

1	2	3	4	5	6	7	8	9	10	11	12	13	14	15
SB1	PL	SB2	SB3	MD	RR	XH	XL	YH	YL	PH	PL	EB1	EB2	EB3

c. Pixel Mode

Instruction of Pixel mode

1	2	3	4	5	6	7	8	9	10	11	12	13	14	15	16
SB1	PL	SB2	SB3	MD	RR	XH	XL	YH	YL	PR	PG	PB	EB1	EB2	EB3

d. Geometry Mode

Instruction of geometry mode

1	2	3	4	5	6	7	8	9	10	11	12	13	14	15	16	17	18	19	20	21
SB1	PL	SB2	SB3	MD	RR	XSH	XSL	YSH	YSL	XEH	XEL	YEH	YEL	LS	LR	LG	LB	EB1	EB2	EB3

e. Clean Mode

Instruction of Clean Mode

1	2	3	4	5	6	7	8	9	10	11	12	13	14	15	16
SB1	PL	SB2	SB3	MD	XSH	XSL	YSH	YSL	XEH	XEL	YEH	YEL	EB1	EB2	EB3

f. PWM Mode

Instruction of Pixel mode

1	2	3	4	5	6	7	8	9	10	11	12	13
SB1	PL	SB2	SB3	MD	PS	PFH	PFL	PDH	PDL	EB1	EB2	EB3

g. Backlight Mode

Instruction of Clean Mode

1	2	3	4	5	6	7	8	9	10	11	12	13	14	15	16
SB1	PL	SB2	SB3	MD	RR	XH	XL	YH	YL	PR	PG	PB	EB1	EB2	EB3

h. TP Compensation Mode

Instruction of Calibration Mode for RTP/CTP

1	2	3	4	5	6	7	8	9	10
SB1	PL	SB2	SB3	MD	BH	BL	EB1	EB2	EB3

M-series TFT Commands Reference Guide

SPI Mode Instruction Table

a. Text Mode

Instruction of text mode

1	2	3	4	5	6	7	8	9	10	11	12	13	14	15	16	17	18	19
0x31	SB3	MD	WR	TR	XH	XL	YH	YL	SR	SG	SB	BR	BG	BB	SDATA	0x0A	0x00	0x0D

b. Graphic Mode

Instruction of Graphic mode:

1	2	3	4	5	6	7	8	9	10	11	12	13
0x31	SB3	MD	RR	XH	XL	YH	YL	PH	PL	0x0A	0x00	0x0D

c. Pixel Mode

Instruction of Pixel mode

1	2	3	4	5	6	7	8	9	10	11	12	13	14
0x31	SB3	MD	RR	XH	XL	YH	YL	PR	PG	PB	0x0A	0x00	0x0D

d. Geometry Mode

Instruction of geometry mode

1	2	3	4	5	6	7	8	9	10	11	12	13	14	15	16	17	18	19
0x31	SB3	MD	RR	XSH	XSL	YSH	YSL	XEH	XEL	YEH	YEL	LS	LR	LG	LB	0x0A	0x00	0x0D

e. Clean Mode

Instruction of Clean Mode

1	2	3	4	5	6	7	8	9	10	11	12	13	14
0x31	SB3	MD	XSH	XSL	YSH	YSL	XEH	XEL	YEH	YEL	0x0A	0x00	0x0D

f. PWM Mode

Instruction of Pixel mode

1	2	3	4	5	6	7	8	9	10	11
0x31	SB3	MD	PS	PFH	PFL	PDH	PDL	0x0A	0x00	0x0D

g. Backlight Mode

Instruction of Clean Mode

1	2	3	4	5	6	7	8	9	10	11	12	13	14
0x31	SB3	MD	RR	XH	XL	YH	YL	PR	PG	PB	0x0A	0x00	0x0D

h. TP Compensation Mode

Instruction of Calibration Mode for RTP/CTP

1	2	3	4	5	6	7	8
0x31	SB3	MD	BH	BL	0x0A	0x00	0x0D

M-series TFT Commands Reference Guide

4.1 Text Mode

Instruction of text mode

1	2	3	4	5	6	7	8	9	10	11	12	13	14	15	16	17	18	19	20	21
SB1	PL	SB2	SB3	MD	WR	TR	XH	XL	YH	YL	SR	SG	SB	BR	BG	BB	SDATA	EB1	EB2	EB3

4.1.1 Instruction Table

No.	Symbol	D7	D6	D5	D4	D3	D2	D1	D0	Describe
1	SB1	0	0	0	0	0	0	0	1	Start Byte
2	PL	PL7	PL6	PL5	PL4	PL3	PL2	PL1	PL0	Package length
3	SB2	0	0	0	0	0	0	1	0	Start Byte
4	SB3	0	0	0	0	0	1	0	0	
5	MD	0	0	1	0	MD3	MD2	MD1	MD0	Mode Selection
6	WR	0	0	WR5	WR4	0	0	WR1	WR0	Word Type / Paint function
7	TR	0	0	TR5	TR4	0	0	TR1	TR0	Transparent /180 rotation
8	XH	0	0	0	0	XH3	XH2	XH1	XH0	Location of X-axis
9	XL	XL7	XL6	XL5	XL4	XL3	XL2	XL1	XL0	
10	YH	0	0	0	0	YH3	YH2	YH1	YH0	Location of Y-axis
11	YL	YL7	YL6	YL5	YL4	YL3	YL2	YL1	YL0	
No.	Symbol	D7	D6	D5	D4	D3	D2	D1	D0	Describe
12	SR	SR7	SR6	SR5	SR4	SR3	SR2	SR1	SR0	String Color
13	SG	SG7	SG6	SG5	SG4	SG3	SG2	SG1	SG0	
14	SB	SB7	SB6	SB5	SB4	SB3	SB2	SB1	SB0	
15	BR	BR7	BR6	BR5	BR4	BR3	BR2	BR1	BR0	Background Color
16	BG	BG7	BG6	BG5	BG4	BG3	BG2	BG1	BG0	
17	BB	BB7	BB6	BB5	BB4	BB3	BB2	BB1	BB0	
18	SDATA									String Data
19	EB1	0	0	0	0	1	0	1	0	End Byte
20	EB2									
21	EB3	0	0	0	0	1	1	0	1	

M-series TFT Commands Reference Guide

4.1.2 Instruction Describe

(A) Start Byte

1. Start Byte1 (SB1)

D7	D6	D5	D4	D3	D2	D1	D0	Byte
0	0	0	0	0	0	0	1	0x01

Before execute, the SB1 is used to be start byte of package

2. Package Length (PL)

D7	D6	D5	D4	D3	D2	D1	D0	Byte
PL7	PL6	PL5	PL4	PL3	PL2	PL1	PL0	0x14+Total Character

PL[7:0]: The total length of package.

Instruction table of mode selection

Mode	Package Length(PL)
Text Mode	0x14+ Total Character
Graphic Mode	0x0F
Pixel Mode	0x10
Geometric Mode	0x15
Erase Mode	0x10
Erase Icon Layer Mode	0x10
PWM Mode	0x0D
Sleep Mode	0x0A
Backlight Mode	0x0A
TP Compensation	0x08

Ex: When choose Text mode and show a string“ Hello”, PL = 0x14 + 0x05 (5 characters) = 0x19.

3. Start Byte2 (SB2)

D7	D6	D5	D4	D3	D2	D1	D0	Byte
0	0	0	0	0	0	1	0	0x02

4. Start Byte3 (SB3)

D7	D6	D5	D4	D3	D2	D1	D0	Byte
0	0	0	0	0	1	0	0	0x04

SB2,3 are used to confirm display specification. (Ex: 0x02 and 0x04 are corresponded M-Series TFT)

M-series TFT Commands Reference Guide

5. Mode (MD)

D7	D6	D5	D4	D3	D2	D1	D0	Byte
MD7	MD6	MD5	MD4	MD3	MD2	MD1	MD0	0x31

MD[3:0] : Choose mode, mode table is below.

Mode		MD7	MD6	MD5	MD4	MD3	MD2	MD1	MD0	Byte
String		0	0	1	1	0	0	0	1	0x31
Graphic		0	0	1	1	0	0	1	0	0x32
Pixel		0	0	1	1	0	0	1	1	0x33
Geometric	Line	0	0	1	1	0	1	0	0	0x34
	Square	0	0	1	1	0	1	1	0	0x35
Erase		0	0	1	1	0	1	1	0	0x36
Erase Icon Layer		0	1	0	0	0	0	0	1	0x41
PWM		0	0	1	1	0	1	1	1	0x37
Sleep		0	0	1	1	1	0	0	0	0x38
Backlight		0	0	1	1	1	0	0	1	0x39
TP Compensation		0	1	1	1	1	1	1	0	0x7E

(B) Function Setting

6. Word Type and Repaint (WR)

D7	D6	D5	D4	D3	D2	D1	D0	Byte(default)
0	WR6	WR5	WR4	0	0	WR1	WR0	0x00

WR[6:4] : Word type selection. The display has one internal type and seven external types.

WR[1:0] : 00→ Icon Layer, 01→ Background, 02→ Erase Icon Layer, 03→Display Layer.

7. Background Transparent and Rotation (TR)

D7	D6	D5	D4	D3	D2	D1	D0	Byte(default)
0	0	TR5	TR4	0	0	TR1	TR0	0x00

TR[5:4] : 00→Transparent background color, 01→Retain background color.

TR[1:0] : 00→Retain display, 01→180 degree rotation.

M-series TFT Commands Reference Guide

(B.1) Location

The location of X/Y-axis are set by two byte (High / Low Byte). When the location is lower than 255, it just use low byte (High byte = 0x00). When the location is higher than 255, it is requested to run in high and low byte. More detail is below.

8. X-axis Location of High Byte (XH)

D7	D6	D5	D4	D3	D2	D1	D0	Byte(default)
0	0	0	0	XH3	XH2	XH1	XH0	0x00

9. X-axis Location of Low Byte (XL)

D7	D6	D5	D4	D3	D2	D1	D0	Byte(default)
XL7	XL6	XL5	XL4	XL3	XL2	XL1	XL0	0x00

10. Y-axis Location of High Byte (YH)

D7	D6	D5	D4	D3	D2	D1	D0	Byte(default)
0	0	0	0	YH3	YH2	YH1	YH0	0x00

11. Y-axis Location of Low Byte (YL)

D7	D6	D5	D4	D3	D2	D1	D0	Byte(default)
YL7	YL6	YL5	YL4	YL3	YL2	YL1	YL0	0x00

Location of X/Y-axis is selected by XH[3:0], XL[7:0] and YH[3:0], YL[7:0].

Ex:

When location is (320, 300),

XH[3:0] = 0x01, XL[7:0] = 0x40 and YH[3:0] = 0x01, YL[7:0] = 0x2C.

When location is (255, 200),

XH[3:0] = 0x00, XL[7:0] = 0xFF and YH[3:0] = 0x00, YL[7:0] = 0xC8.

M-series TFT Commands Reference Guide

(B.2) Color

Clever System M-Series TFT support 24Bits Full Color (RGB888). Each color is composed by three primary colors (Red Green and Blue). More detail is below.

12. String Color of Red Composition (SR)

D7	D6	D5	D4	D3	D2	D1	D0	Byte(default)
SR7	SR6	SR5	SR4	SR3	SR2	SR1	SR0	0x00

13. String Color of Green Composition (SG)

D7	D6	D5	D4	D3	D2	D1	D0	Byte(default)
SG7	SG6	SG5	SG4	SG3	SG2	SG1	SG0	0x00

14. String Color of Blue Composition (SB)

D7	D6	D5	D4	D3	D2	D1	D0	Byte(default)
SB7	SB6	SB5	SB4	SB3	SB2	SB1	SB0	0x00

SR[7:0] : Set string color of red composition.

SG[7:0] : Set string color of green composition.

SB[7:0] : Set string color of blue composition.

15. Background Color of Red Composition (BR)

D7	D6	D5	D4	D3	D2	D1	D0	Byte(default)
BR7	BR6	BR5	BR4	BR3	BR2	BR1	BR0	0x00

16. Background Color of Green Composition (BG)

D7	D6	D5	D4	D3	D2	D1	D0	Byte(default)
BG7	BG6	BG5	BG4	BG3	BG2	BG1	BG0	0x00

M-series TFT Commands Reference Guide

17. Background Color of Blue Composition (BB)

D7	D6	D5	D4	D3	D2	D1	D0	Byte(default)
BB7	BB6	BB5	BB4	BB3	BB2	BB1	BB0	0x00

BR[7:0] : Set background color of red composition.

BG[7:0] : Set background color of green composition.

BB[7:0] : Set background color of blue composition.

18. String Data (SData)

Clever System M-Series TFT shows word corresponding ASCII Table.

Ex : (1)When show " A ", SData = 0x41.

(2)When show " Hello! ", User sends six bytes continuously. SData = 0x48, 0x65, 0x6C, 0x6C, 0x6F, 0x21.

(C) End Byte

19. End Byte1 (EB1)

D7	D6	D5	D4	D3	D2	D1	D0	Byte(default)
0	0	0	0	1	0	1	0	0x0A

EB1 is instruction ending byte.

20. End Byte2 (EB2)

EB 2 is used for check correct instruction, EB2 = last eight bits of sum, which is from SB1 to EB1.

Ex: Example instruction is "0x01,0x17,0x02,0x04,0x31,0x00,0x00,0x00,0x00,

0x00,0x00,0x00,0x00,0x00,0x00,0xFF,0xFF,0xFF,"ABC",0x0A".

$EB2 = (0x01+0x17+.....+0xFF+0xFF+0x41+0x42+0x43+0x0A)/\text{mod } 256 = 0x1C.$

21. End Byte3 (EB3)

D7	D6	D5	D4	D3	D2	D1	D0	Byte(default)
0	0	0	0	1	1	0	1	0x0D

EB3 is package ending byte.

M-series TFT Commands Reference Guide

4.2 Graphic Mode

Instruction of Graphic mode:

1	2	3	4	5	6	7	8	9	10	11	12	13	14	15
SB1	PL	SB2	SB3	MD	RR	XH	XL	YH	YL	PH	PL	EB1	EB2	EB3

4.2.1 Instruction table

No.	Symbol	D7	D6	D5	D4	D3	D2	D1	D0	Describe
1	SB1	0	0	0	0	0	0	0	1	Start Byte
2	PL	PL7	PL6	PL5	PL4	PL3	PL2	PL1	PL0	Package Length
3	SB2	0	0	0	0	0	0	1	0	Start Byte
4	SB3	0	0	0	0	0	1	0	0	
5	MD	0	0	1	0	MD3	MD2	MD1	MD0	Mode Selection
6	RR	0	0	RR5	RR4	0	0	RR1	RR0	180 rotation / Repaint
7	XH	0	0	0	0	XH3	XH2	XH1	XH0	Location of X-axis
8	XL	XL7	XL6	XL5	XL4	XL3	XL2	XL1	XL0	
9	YH	0	0	0	0	YH3	YH2	YH1	YH0	Location of Y-axis
10	YL	YL7	YL6	YL5	YL4	YL3	YL2	YL1	YL0	
11	PH	0	0	0	0	PH3	PH 2	PH 1	PH 0	Picture Number
12	PLW	PLW7	PLW6	PLW5	PLW4	PLW3	PLW2	PLW1	PLW0	
13	EB1	0	0	0	0	1	0	1	0	End byte
14	EB2									
15	EB3	0	0	0	0	1	1	0	1	

M-series TFT Commands Reference Guide

4.2.2 Instruction Describe

(A) Start Byte

1. Start Byte1 (SB1)

D7	D6	D5	D4	D3	D2	D1	D0	Byte
0	0	0	0	0	0	0	1	0x01

Before execute, the SB 1 is used to be start byte of package.

2. Package Length (PL)

D7	D6	D5	D4	D3	D2	D1	D0	Byte
PL7	PL6	PL5	PL4	PL3	PL2	PL1	PL0	0x0F

PL[7:0]: The total length of package.

For more information, please refer to page 12.

3. Start Byte2 (SB2)

D7	D6	D5	D4	D3	D2	D1	D0	Byte
0	0	0	0	0	0	1	0	0x02

4. Start Byte3 (SB3)

D7	D6	D5	D4	D3	D2	D1	D0	Byte
0	0	0	0	0	1	0	0	0x04

SB2,3 are used to confirm display size. (Ex: 0x02 and 0x04 are corresponded M-Series TFT'')

5. Mode (MD)

D7	D6	D5	D4	D3	D2	D1	D0	Byte
0	0	1	0	MD3	MD2	MD1	MD0	0x32

The MD[3:0] is set by mode table, please refer to page 13.

M-series TFT Commands Reference Guide

(B) Function Setting

6. Rotation and Re Paint (RR)

D7	D6	D5	D4	D3	D2	D1	D0	Byte
0	0	RR5	RR4	0	0	RR1	RR0	0x32

RR[5:4] : 00→ Retain display, 01→180 degree rotation.

RR[1:0] : 00→ Icon Layer, 01→ Background, 02→ Erase Icon Layer, 03→Display Layer.

7. X-axis Location of High Byte (XH)

D7	D6	D5	D4	D3	D2	D1	D0	Byte(default)
0	0	0	0	XH3	XH2	XH1	XH0	0x00

8. X-axis Location of Low Byte (XL)

D7	D6	D5	D4	D3	D2	D1	D0	Byte(default)
XL7	XL6	XL5	XL4	XL3	XL2	XL1	XL0	0x00

9. Y-axis Location of High Byte (YH)

D7	D6	D5	D4	D3	D2	D1	D0	Byte(default)
0	0	0	0	YH3	YH2	YH1	YH0	0x00

10. Y-axis Location of Low Byte (YL)

D7	D6	D5	D4	D3	D2	D1	D0	Byte(default)
YL7	YL6	YL5	YL4	YL3	YL2	YL1	YL0	0x00

Location of X/Y-axis is selected by XH[3:0], XL[7:0] and YH[3:0], YL[7:0].

For more information, please refer to (B.1)Location.(Page 14).

11. Picture Number of High Byte (PH)

D7	D6	D5	D4	D3	D2	D1	D0	Byte(default)
0	0	0	0	PH3	PH 2	PH 1	PH 0	0x00

M-series TFT Commands Reference Guide

12. Picture Number of Low Byte (PLW)

D7	D6	D5	D4	D3	D2	D1	D0	Byte(default)
PLW7	PLW 6	PLW 5	PLW 4	PLW 3	PLW 2	PL W1	PLW 0	0x00

Picture number is selected by PH[3:0] and PLW[7:0].

Ex: Picture number is 10, PH[3:0] = 0x00, PLW[7:0] = 0x09.

(C) End Byte

13. End Byte1 (EB1)

D7	D6	D5	D4	D3	D2	D1	D0	Byte(default)
0	0	0	0	1	0	1	0	0x0A

EB1 is the instruction ending byte.

14. End Byte2 (EB2)

EB2 is used for check correct instruction, EB2 = last eight bits of sum, which is from SB1 to EB1.

For more detail setting information, please refer to Page 16.

15. End Byte3 (EB3)

D7	D6	D5	D4	D3	D2	D1	D0	Byte(default)
0	0	0	0	1	1	0	1	0x0D

EB3 is the package ending byte.

M-series TFT Commands Reference Guide

4.3 Pixel Mode

Instruction of Pixel mode

1	2	3	4	5	6	7	8	9	10	11	12	13	14	15	16
SB1	PL	SB2	SB3	MD	RR	XH	XL	YH	YL	PR	PG	PB	EB1	EB2	EB3

4.3.1 Instruction Table

No.	Symbol	D7	D6	D5	D4	D3	D2	D1	D0	Describe
1	SB1	0	0	0	0	0	0	0	1	Start Byte
2	PL	PL7	PL6	PL5	PL4	PL3	PL2	PL1	PL0	Package Length
3	SB2	0	0	0	0	0	0	1	0	Start Byte
4	SB3	0	0	0	0	0	1	0	0	
5	MD	0	0	1	0	MD3	MD2	MD1	MD0	Mode Selection
6	RR	0	0	RR5	RR4	0	0	RR1	RR0	180 rotation / Repaint
7	XH	0	0	0	0	XH3	XH2	XH1	XH0	Location of X-axis
8	XL	XL7	XL6	XL5	XL4	XL3	XL2	XL1	XL0	
9	YH	0	0	0	0	YH3	YH2	YH1	YH0	Location of Y-axis
10	YL	YL7	YL6	YL5	YL4	YL3	YL2	YL1	YL0	
11	PR	PR7	PR6	PR5	PR4	PR3	PR2	PR1	PR0	Pixel Color
12	PG	PG7	PG6	PG5	PG4	PG3	PG2	PG1	PG0	
13	PB	PB7	PB6	PB5	PB4	PB3	PB2	PB1	PB0	
14	EB1	0	0	0	0	1	0	1	0	End byte
15	EB2									
16	EB3	0	0	0	0	1	1	0	1	

M-series TFT Commands Reference Guide

4.3.2 Instruction Describe

(A) Start Byte

1. Start Byte1 (SB1)

D7	D6	D5	D4	D3	D2	D1	D0	Byte
0	0	0	0	0	0	0	1	0x01

Before execute, the SB 1 is used to be start byte of package.

2. Package Length (PL)

D7	D6	D5	D4	D3	D2	D1	D0	Byte
PL7	PL6	PL5	PL4	PL3	PL2	PL1	PL0	0x10

PL[7:0]: The total length of package.

For more information, please refer to page 12.

3. Start Byte2 (SB2)

D7	D6	D5	D4	D3	D2	D1	D0	Byte
0	0	0	0	0	0	1	0	0x02

4. Start Byte3 (SB3)

D7	D6	D5	D4	D3	D2	D1	D0	Byte
0	0	0	0	0	1	0	0	0x04

SB2,3 are used to confirm display size. (Ex: 0x02 and 0x04 are corresponded M-Series TFT)

5. Mode (MD)

D7	D6	D5	D4	D3	D2	D1	D0	Byte
0	0	1	0	MD3	MD2	MD1	MD0	0x33

The MD[3:0] is set by mode table, please refer to page 13.

M-series TFT Commands Reference Guide

(B) Function Setting

6. Rotation and Re Paint (RR)

D7	D6	D5	D4	D3	D2	D1	D0	Byte
0	0	RR5	RR4	0	0	RR1	RR0	0x00

RR[5:4] : 00→Retain text layer , 01→180 degree rotation of text layer ◦

RR[1:0] : 00→ Icon Layer, 01→ Background, 02→ Erase Icon Layer, 03→Display Layer.

7. X-axis Location of High Byte (XH)

D7	D6	D5	D4	D3	D2	D1	D0	Byte(default)
0	0	0	0	XH3	XH2	XH1	XH0	0x00

8. X-axis Location of Low Byte (XL)

D7	D6	D5	D4	D3	D2	D1	D0	Byte(default)
XL7	XL6	XL5	XL4	XL3	XL2	XL1	XL0	0x00

9. Y-axis Location of High Byte (YH)

D7	D6	D5	D4	D3	D2	D1	D0	Byte(default)
0	0	0	0	YH3	YH2	YH1	YH0	0x00

10. Y-axis Location of Low Byte (YL)

D7	D6	D5	D4	D3	D2	D1	D0	Byte(default)
YL7	YL6	YL5	YL4	YL3	YL2	YL1	YL0	0x00

Location of X/Y-axis is selected by XH[3:0], XL[7:0] and YH[3:0], YL[7:0].

For more location setting information, please refer to Page 14.

M-series TFT Commands Reference Guide

11. Pixel Color of Red Composition (BR)

D7	D6	D5	D4	D3	D2	D1	D0	Byte(default)
PR7	PR6	PR5	PR4	PR3	PR2	PR1	PR0	0x00

12. Pixel Color of Green Composition (BG)

D7	D6	D5	D4	D3	D2	D1	D0	Byte(default)
PG7	PG6	PG5	PG4	PG3	PG2	PG1	PG0	0x00

13. Pixel Color of Blue Composition (BB)

D7	D6	D5	D4	D3	D2	D1	D0	Byte(default)
PB7	PB6	PB5	PB4	PB3	PB2	PB1	PB0	0x00

PR[7:0] : Set Pixel color of red composition ◦

PG[7:0] : Set Pixel color of green composition ◦

PB[7:0] : Set Pixel color of blue composition ◦

For more color setting information, please refer to (B.2) Color.(Page 15).

(C) End Byte

14. End Byte1 (EB1)

D7	D6	D5	D4	D3	D2	D1	D0	Byte(default)
0	0	0	0	1	0	1	0	0x0A

EB1 is instruction ending byte.

15. End Byte2 (EB2)

EB2 is used for check correct instruction, EB2 = last eight bits of sum, which is from SB1 to EB1.

For more detail setting information, please refer to Page 16.

16. End Byte3 (EB3)

D7	D6	D5	D4	D3	D2	D1	D0	Byte(default)
0	0	0	0	1	1	0	1	0x0D

EB3 is package ending byte.

M-series TFT Commands Reference Guide

4.4 Geometry Mode

In Geometry mode, it provide line segment and square drawing, more detail is below.

Instruction of geometry mode

1	2	3	4	5	6	7	8	9	10	11	12	13	14	15	16	17	18	19	20	21
SB1	PL	SB2	SB3	MD	RR	XSH	XSL	YSH	YSL	XEH	XEL	YEH	YEL	LS	LR	LG	LB	EB1	EB2	EB3

4.4.1 Instruction Describe

No.	Symbol	D7	D6	D5	D4	D3	D2	D1	D0	Describe
1	SB1	0	0	0	0	0	0	0	1	Start Byte
2	PL	PL7	PL6	PL5	PL4	PL3	PL2	PL1	PL0	Package Length
3	SB2	0	0	0	0	0	0	1	0	Start Byte
4	SB3	0	0	0	0	0	1	0	0	
5	MD	0	0	1	0	MD3	MD2	MD1	MD0	Mode Selection
6	RR	0	0	RR5	RR4	0	0	RR1	RR0	180 Rotation / Repaint
7	XSH	0	0	0	0	XSH3	XSH2	XSH1	XSH0	Start Location of X-axis
8	XSL	XSL7	XSL6	XSL5	XSL4	XSL3	XSL2	XSL1	XSL0	
9	YSH	0	0	0	0	YSH3	YSH2	YSH1	YSH0	Start Location of Y-axis
10	YSL	YSL7	YL6	YSL5	YSL4	YSL3	YSL2	YSL1	YSL0	
11	XEH	0	0	0	0	XEH3	XEH2	XEH1	XEH0	End Location of X-axis
12	XEL	XEL7	XEL6	XEL5	XEL4	XEL3	XEL2	XEL1	XEL0	
13	YEH	0	0	0	0	YEH3	YEH2	YEH1	YEH0	End Location of Y-axis
14	YEL	YEL7	YEL6	YEL5	YEL4	YEL3	YEL2	YEL1	YEL0	
15	LS	LS7	LS6	LS5	LS4	LS3	LS2	LS1	LS0	Segment Size
16	LR	LR7	LR6	LR5	LR4	LR3	LR2	LR1	LR0	Segment Color
17	LG	LG7	LG6	LG5	LG4	LG3	LG2	LG1	LG0	
18	LB	LB7	LB6	LB5	LB4	LB3	LB2	LB1	LB0	
19	EB1	0	0	0	0	1	0	1	0	End Byte
20	EB2									
21	EB3	0	0	0	0	1	1	0	1	

M-series TFT Commands Reference Guide

4.4.2 Instruction Describe

(A) Start Byte

1. Start Byte1 (SB1)

D7	D6	D5	D4	D3	D2	D1	D0	Byte
0	0	0	0	0	0	0	1	0x01

Before execute, the SB 1 is used to be start byte of package.

2. Package Length (PL)

D7	D6	D5	D4	D3	D2	D1	D0	Byte
PL7	PL6	PL5	PL4	PL3	PL2	PL1	PL0	0x15

PL[7:0]: The total length of package.

For more information, please refer to page 12.

3. Start Byte2 (SB2)

D7	D6	D5	D4	D3	D2	D1	D0	Byte
0	0	0	0	0	0	1	0	0x02

4. Start Byte3 (SB3)

D7	D6	D5	D4	D3	D2	D1	D0	Byte
0	0	0	0	0	1	0	0	0x04

SB2,3 are used to confirm display size. (Ex: 0x02 and 0x04 are corresponded M-Series TFT)

5. Mode (MD)

D7	D6	D5	D4	D3	D2	D1	D0	Byte
0	0	1	0	MD3	MD2	MD1	MD0	0x34(Line) and 0x35(Square)

The MD[3:0] is set by mode table, please refer to page 13.

M-series TFT Commands Reference Guide

(B) Function Setting

6. Rotation and Re Paint (RR)

D7	D6	D5	D4	D3	D2	D1	D0	Byte
0	0	RR5	RR4	0	0	RR1	RR0	0x00

RR[5:4] : 00→Retain text layer , 01→180 degree rotation of text layer ◦

RR[1:0] : 00→ Icon Layer, 01→ Background, 02→ Erase Icon Layer, 03→Display Layer.

7. X-axis Start Location of High Byte (XSH)

D7	D6	D5	D4	D3	D2	D1	D0	Byte(default)
0	0	0	0	XSH3	XSH2	XSH1	XSH0	0x00

8. X-axis Start Location of Low Byte (XSL)

D7	D6	D5	D4	D3	D2	D1	D0	Byte(default)
XSL7	XSL6	XSL5	XSL4	XSL3	XSL2	XSL1	XSL0	0x00

9. Y-axis Start Location of High Byte (YSH)

D7	D6	D5	D4	D3	D2	D1	D0	Byte(default)
0	0	0	0	YSH3	YSH2	YSH1	YSH0	0x00

10. Y-axis Start Location of Low Byte (YSL)

D7	D6	D5	D4	D3	D2	D1	D0	Byte(default)
YSL7	YL6	YSL5	YSL4	YSL3	YSL2	YSL1	YSL0	0x00

11. X-axis End Location of High Byte (XEH)

D7	D6	D5	D4	D3	D2	D1	D0	Byte(default)
0	0	0	0	XEH3	XEH2	XEH1	XEH0	0x00

12. X-axis End Location of Low Byte (XEL)

D7	D6	D5	D4	D3	D2	D1	D0	Byte(default)
XEL7	XEL6	XEL5	XEL4	XEL3	XEL2	XEL1	XEL0	0x00

M-series TFT Commands Reference Guide

13. Y-axis End Location of High Byte (YEH)

D7	D6	D5	D4	D3	D2	D1	D0	Byte(default)
0	0	0	0	YEH3	YEH2	YEH1	YEH0	0x00

14. Y-axis End Location of Low Byte (YEL)

D7	D6	D5	D4	D3	D2	D1	D0	Byte(default)
YEL7	YEL6	YEL5	YEL4	YEL3	YEL2	YEL1	YEL0	0x00

Start Location of X/Y-axis is selected by XSH[3:0], XSL[7:0] and YSH[3:0], YSL[7:0].

End Location of X/Y-axis is selected by XEH[3:0], XEL[7:0] and YEH[3:0], YEL[7:0].

For more location setting information, please refer to Page 14.

Notice : Start Location should be less than End Location.

15. Line Size (LS)

D7	D6	D5	D4	D3	D2	D1	D0	Byte(default)
LS7	LS6	LS5	LS4	LS3	LS2	LS1	LS0	0x01

LS[7:0] : Size of Line segment.

16. Line Color of Red Composition (BR)

D7	D6	D5	D4	D3	D2	D1	D0	Byte(default)
LR7	LR6	LR5	LR4	LR3	LR2	LR1	LR0	0x00

17. Line Color of Green Composition (BG)

D7	D6	D5	D4	D3	D2	D1	D0	Byte(default)
LG7	LG6	LG5	LG4	LG3	LG2	LG1	LG0	0x00

18. Line Color of Blue Composition (BB)

D7	D6	D5	D4	D3	D2	D1	D0	Byte(default)
LB7	LB6	LB5	LB4	LB3	LB2	LB1	LB0	0x00

LR[7:0] : Set Pixel color of red composition ◦

LG[7:0] : Set Pixel color of green composition ◦

LB[7:0] : Set Pixel color of blue composition ◦

For more color setting information, please refer to (B.2) Color. (Page 15)

M-series TFT Commands Reference Guide

(C) End Byte

19. End Byte1 (EB1)

D7	D6	D5	D4	D3	D2	D1	D0	Byte(default)
0	0	0	0	1	0	1	0	0x0A

EB1 is instruction ending byte.

20. End Byte2 (EB2)

EB2 is used for check correct instruction, EB2 = last eight bits of sum, which is from SB1 to EB1.

For more detail setting information, please refer to Page 16.

21. End Byte3 (EB3)

D7	D6	D5	D4	D3	D2	D1	D0	Byte(default)
0	0	0	0	1	1	0	1	0x0D

EB3 is package ending byte.

M-series TFT Commands Reference Guide

4.5 Erase Mode & Erase Icon Layer Mode

Instruction of Clean Mode

1	2	3	4	5	6	7	8	9	10	11	12	13	14	15	16
SB1	PL	SB2	SB3	MD	XSH	XSL	YSH	YSL	XEH	XEL	YEH	YEL	EB1	EB2	EB3

4.5.1 Instruction table

No.	Symbol	D7	D6	D5	D4	D3	D2	D1	D0	Describe
1	SB1	0	0	0	0	0	0	0	1	Start Byte
2	PL	PL7	PL6	PL5	PL4	PL3	PL2	PL1	PL0	Package Length
3	SB2	0	0	0	0	0	0	1	0	Start Byte
4	SB3	0	0	0	0	0	1	0	0	Start Byte
5	MD	0	0	1	0	MD3	MD2	MD1	MD0	Mode Selection
6	XSH	0	0	0	0	XSH3	XSH2	XSH1	XSH0	Start Location of X-axis
7	XSL	XSL7	XSL6	XSL5	XSL4	XSL3	XSL2	XSL1	XSL0	
8	YSH	0	0	0	0	YSH3	YSH2	YSH1	YSH0	Start Location of Y-axis
9	YSL	YSL7	YSL6	YSL5	YSL4	YSL3	YSL2	YSL1	YSL0	
10	XEH	0	0	0	0	XEH3	XEH2	XEH1	XEH0	End Location of X-axis
11	XEL	XEL7	XEL6	XEL5	XEL4	XEL3	XEL2	XEL1	XEL0	
12	YEH	0	0	0	0	YEH3	YEH2	YEH1	YEH0	End Location of Y-axis
13	YEL	YEL7	YEL6	YEL5	YEL4	YEL3	YEL2	YEL1	YEL0	
14	EB1	0	0	0	0	1	0	1	0	End Byte
15	EB2									
16	EB3	0	0	0	0	1	1	0	1	

M-series TFT Commands Reference Guide

4.5.2 Instruction Describe

(A) Start Byte

1. Start Byte1 (SB1)

D7	D6	D5	D4	D3	D2	D1	D0	Byte
0	0	0	0	0	0	0	1	0x01

Before execute, the SB 1 is used to be start byte of package.

2. Package Length (PL)

D7	D6	D5	D4	D3	D2	D1	D0	Byte
PL7	PL6	PL5	PL4	PL3	PL2	PL1	PL0	0x10

PL[7:0]: The total length of package.

For more information, please refer to page 12.

3. Start Byte2 (SB2)

D7	D6	D5	D4	D3	D2	D1	D0	Byte
0	0	0	0	0	0	1	0	0x02

4. Start Byte3 (SB3)

D7	D6	D5	D4	D3	D2	D1	D0	Byte
0	0	0	0	0	1	0	0	0x04

SB2,3 are used to confirm display size. (Ex: 0x02 and 0x04 are corresponded M-Series TFT'')

5. Mode (MD)

Erase Mode

D7	D6	D5	D4	D3	D2	D1	D0	Byte
0	0	1	0	MD3	MD2	MD1	MD0	0x36

The MD[3:0] is set by mode table, please refer to page 13.

M-series TFT Commands Reference Guide

Erase Icon Layer Mode

D7	D6	D5	D4	D3	D2	D1	D0	Byte
0	1	0	0	MD3	MD2	MD1	MD0	0x41

The MD[3:0] is set by mode table, please refer to page 13.

(B) Function Setting

6. X-axis Start Location of High Byte (XSH)

D7	D6	D5	D4	D3	D2	D1	D0	Byte(default)
0	0	0	0	XSH3	XSH2	XSH1	XSH0	0x00

7. X-axis Start Location of Low Byte (XSL)

D7	D6	D5	D4	D3	D2	D1	D0	Byte(default)
XSL7	XSL6	XSL5	XSL4	XSL3	XSL2	XSL1	XSL0	0x00

8. Y-axis Start Location of High Byte (YSH)

D7	D6	D5	D4	D3	D2	D1	D0	Byte(default)
0	0	0	0	YSH3	YSH2	YSH1	YSH0	0x00

9. Y-axis Start Location of Low Byte (YSL)

D7	D6	D5	D4	D3	D2	D1	D0	Byte(default)
YSL7	YSL6	YSL5	YSL4	YSL3	YSL2	YSL1	YSL0	0x00

10. X-axis End Location of High Byte (XEH)

D7	D6	D5	D4	D3	D2	D1	D0	Byte(default)
0	0	0	0	XEH3	XEH2	XEH1	XEH0	0x00

11. X-axis End Location of Low Byte (XEL)

D7	D6	D5	D4	D3	D2	D1	D0	Byte(default)
XEL7	XEL6	XEL5	XEL4	XEL3	XEL2	XEL1	XEL0	0x00

M-series TFT Commands Reference Guide

12. Y-axis End Location of High Byte (YEH)

D7	D6	D5	D4	D3	D2	D1	D0	Byte(default)
0	0	0	0	YEH3	YEH2	YEH1	YEH0	0x00

13. Y-axis End Location of Low Byte (YEL)

D7	D6	D5	D4	D3	D2	D1	D0	Byte(default)
YEL7	YEL6	YEL5	YEL4	YEL3	YEL2	YEL1	YEL0	0x00

Start Location of X/Y-axis is selected by XSH[3:0], XSL[7:0] and YSH[3:0], YSL[7:0].

End Location of X/Y-axis is selected by XEH[3:0], XEL[7:0] and YEH[3:0], YEL[7:0].

For more location setting information, please refer to Page 14.

Notice: Start Location should be less than End Location.

(C) End Byte

14. End Byte1 (EB1)

D7	D6	D5	D4	D3	D2	D1	D0	Byte(default)
0	0	0	0	1	0	1	0	0x0A

EB1 is instruction ending byte.

15. End Byte2 (EB2)

EB2 is used for check correct instruction, EB2 = last eight bits of sum, which is from SB1 to EB1.

For more detail setting information, please refer to Page 16.

16. End Byte3 (EB3)

D7	D6	D5	D4	D3	D2	D1	D0	Byte(default)
0	0	0	0	1	1	0	1	0x0D

EB3 is package ending byte.

M-series TFT Commands Reference Guide

4.6 PWM Mode

Instruction of Pixel mode

1	2	3	4	5	6	7	8	9	10	11	12	13
SB1	PL	SB2	SB3	MD	PS	PFH	PFL	PDH	PDL	EB1	EB2	EB3

4.6.1 Instruction Describe

No.	Symbol	D7	D6	D5	D4	D3	D2	D1	D0	Describe
1	SB1	0	0	0	0	0	0	0	1	Start Byte
2	PL	PL7	PL6	PL5	PL4	PL3	PL2	PL1	PL0	Package Length
3	SB2	0	0	0	0	0	0	1	0	Start Byte
4	SB3	0	0	0	0	0	1	0	0	Start Byte
5	MD	0	0	1	0	MD3	MD2	MD1	MD0	Mode Selection
6	PS	0	0	0	0	0	0	0	PS0	PWM Setting
7	PFH	0	0	0	0	0	0	0	0	PWM Frequency
8	PFL	PFL7	PFL6	PFL5	PFL4	PFL3	PFL2	PFL1	PFL0	
9	PDH	0	0	0	0	0	0	0	0	PWM Duty cycle
10	PDL	PDL7	PDL6	PDL5	PDL4	PDL3	PDL2	PDL1	PDL0	
11	EB1	0	0	0	0	1	0	1	0	End byte
12	EB2									
13	EB3	0	0	0	0	1	1	0	1	

M-series TFT Commands Reference Guide

4.6.2 Instruction Describe

(A) Start Byte

1. Start Byte1 (SB1)

D7	D6	D5	D4	D3	D2	D1	D0	Byte
0	0	0	0	0	0	0	1	0x01

Before execute, the SB 1 is used to be start byte of package.

2. Package Length (PL)

D7	D6	D5	D4	D3	D2	D1	D0	Byte
PL7	PL6	PL5	PL4	PL3	PL2	PL1	PL0	0x0D

PL[7:0]: The total length of package.

For more information, please refer to page 12.

3. Start Byte2 (SB2)

D7	D6	D5	D4	D3	D2	D1	D0	Byte
0	0	0	0	0	0	1	0	0x02

4. Start Byte3 (SB3)

D7	D6	D5	D4	D3	D2	D1	D0	Byte
0	0	0	0	0	1	0	0	0x04

SB2,3 are used to confirm display size. (Ex: 0x02 and 0x04 are corresponded M-Series TFT)

5. Mode (MD)

D7	D6	D5	D4	D3	D2	D1	D0	Byte
0	0	1	0	MD3	MD2	MD1	MD0	0x37

The MD[3:0] is set by mode table, please refer to page 13.

M-series TFT Commands Reference Guide

(B) Function Setting

6. PWM Setting (PS)

D7	D6	D5	D4	D3	D2	D1	D0	Byte
0	0	0	1	0	0	0	1	0x11

7. PWM Frequency of High Byte (PFH)

D7	D6	D5	D4	D3	D2	D1	D0	Byte(default)
0	0	0	0	0	0	0	0	0x00

8. PWM Frequency of Low Byte (PFL)

D7	D6	D5	D4	D3	D2	D1	D0	Byte(default)
PFL7	PFL6	PFL5	PFL4	PFL3	PFL2	PFL1	PFL0	0x00

PWM frequency is set by PFL[7:0] and PFH[7:0].

9. PWM Duty Cycle of High Byte (PDH)

D7	D6	D5	D4	D3	D2	D1	D0	Byte(default)
0	0	0	0	0	0	0	0	0x00

10. PWM Duty Cycle of Low Byte (PDL)

D7	D6	D5	D4	D3	D2	D1	D0	Byte(default)
PDL7	PDL6	PDL5	PDL4	PDL3	PDL2	PDL1	PDL0	0x00

PWM Duty Cycle is set by PDL[7:0] and PDH[7:0].

M-series TFT Commands Reference Guide

(C) End Byte

11. End Byte1 (EB1)

D7	D6	D5	D4	D3	D2	D1	D0	Byte(default)
0	0	0	0	1	0	1	0	0x0A

EB1 is instruction ending byte.

12. End Byte2 (EB2)

EB2 is used for check correct instruction, EB2 = last eight bits of sum, which is from SB1 to EB1.

For more detail setting information, please refer to Page 16.

13. End Byte3 (EB3)

D7	D6	D5	D4	D3	D2	D1	D0	Byte(default)
0	0	0	0	1	1	0	1	0x0D

EB3 is package ending byte.

M-series TFT Commands Reference Guide

4.7 Power Mode

Instruction of Clean Mode

1	2	3	4	5	6	7	8	9	10
SB1	PL	SB2	SB3	MD	PS	PF	EB1	EB2	EB3

4.7.1 Instruction table

No.	Symbol	D7	D6	D5	D4	D3	D2	D1	D0	Describe	
1	SB1	0	0	0	0	0	0	0	1	Start Byte	
2	PL	PL7	PL6	PL5	PL4	PL3	PL2	PL1	PL0	Package Length	
3	SB2	0	0	0	0	0	0	1	0	Start Byte	
4	SB3	0	0	0	0	0	1	0	0	Start Byte	
5	MD	0	0	1	0	MD3	MD2	MD1	MD0	Mode Selection	
6	PS	0	0	1	0	0	0	1	1	Power Setting	
7	PF	0	0	0	0	0	0	0	PF0	Power Function On/Off	
8	EB1	0	0	0	0	1	0	1	0	End Byte	
9	EB2										
10	EB3	0	0	0	0	1	1	0	1		

M-series TFT Commands Reference Guide

4.7.2 Instruction Describe

(A) Start Byte

1. Start Byte1 (SB1)

D7	D6	D5	D4	D3	D2	D1	D0	Byte
0	0	0	0	0	0	0	1	0x01

Before execute, the SB 1 is used to be start byte of package.

2. Package Length (PL)

D7	D6	D5	D4	D3	D2	D1	D0	Byte
PL7	PL6	PL5	PL4	PL3	PL2	PL1	PL0	0x0A

PL[7:0]: The total length of package.

For more information, please refer to page 12.

3. Start Byte2 (SB2)

D7	D6	D5	D4	D3	D2	D1	D0	Byte
0	0	0	0	0	0	1	0	0x02

4. Start Byte3 (SB3)

D7	D6	D5	D4	D3	D2	D1	D0	Byte
0	0	0	0	0	1	0	0	0x04

SB2,3 are used to confirm display size. (Ex: 0x02 and 0x04 are corresponded M-Series TFT'')

5. Mode (MD)

D7	D6	D5	D4	D3	D2	D1	D0	Byte
0	0	1	0	MD3	MD2	MD1	MD0	0x38

The MD[3:0] is set by mode table, please refer to page 13.

M-series TFT Commands Reference Guide

(B) Function Setting

6. Power Function Setting (PS)

D7	D6	D5	D4	D3	D2	D1	D0	Byte(default)
0	0	1	0	0	0	0	1	0x21

PS is used to set Power Mode.(Ex: 0x21 is Sleep Mode)

7. Power Function On/Off (PF)

D7	D6	D5	D4	D3	D2	D1	D0	Byte(default)
0	0	0	0	0	0	0	PF0	0x00

PF 0 : 0→Power Function off, 1→Power Function on.

(C) End Byte

8. End Byte1 (EB1)

D7	D6	D5	D4	D3	D2	D1	D0	Byte(default)
0	0	0	0	1	0	1	0	0x0A

EB1 is instruction ending byte.

9. End Byte2 (EB2)

EB2 is used for check correct instruction, EB2 = last eight bits of sum, which is from SB1 to EB1.

For more detail setting information, please refer to Page 16.

10. End Byte3 (EB3)

D7	D6	D5	D4	D3	D2	D1	D0	Byte(default)
0	0	0	0	1	1	0	1	0x0D

EB3 is package ending byte.

M-series TFT Commands Reference Guide

4.8 Backlight Mode

Instruction of Clean Mode

1	2	3	4	5	6	7	8	9	10
SB1	PL	SB2	SB3	MD	BH	BL	EB1	EB2	EB3

4.8.1 Instruction table

No.	Symbol	D7	D6	D5	D4	D3	D2	D1	D0	Describe	
1	SB1	0	0	0	0	0	0	0	1	Start Byte	
2	PL	PL7	PL6	PL5	PL4	PL3	PL2	PL1	PL0	Package Length	
3	SB2	0	0	0	0	0	0	1	0	Start Byte	
4	SB3	0	0	0	0	0	1	0	0	Start Byte	
5	MD	0	0	1	0	MD3	MD2	MD1	MD0	Mode Selection	
6	BH	0	0	0	0	0	0	0	0	Brightness	
7	BL	BL7	BL6	BL5	BL4	BL3	BL2	BL1	BL0		
8	EB1	0	0	0	0	1	0	1	0	End Byte	
9	EB2										
10	EB3	0	0	0	0	1	1	0	1		

M-series TFT Commands Reference Guide

4.8.2 Instruction Describe

(A) Start Byte

1. Start Byte1 (SB1)

D7	D6	D5	D4	D3	D2	D1	D0	Byte
0	0	0	0	0	0	0	1	0x01

Before execute, the SB 1 is used to be start byte of package.

2. Package Length (PL)

D7	D6	D5	D4	D3	D2	D1	D0	Byte
PL7	PL6	PL5	PL4	PL3	PL2	PL1	PL0	0x0A

PL[7:0]: The total length of package.

For more information, please refer to page 12.

3. Start Byte2 (SB2)

D7	D6	D5	D4	D3	D2	D1	D0	Byte
0	0	0	0	0	0	1	0	0x02

4. Start Byte3 (SB3)

D7	D6	D5	D4	D3	D2	D1	D0	Byte
0	0	0	0	0	1	0	0	0x04

SB2,3 are used to confirm display size. (Ex: 0x02 and 0x04 are corresponded M-Series TFT'')

5. Mode (MD)

D7	D6	D5	D4	D3	D2	D1	D0	Byte
0	0	1	0	MD3	MD2	MD1	MD0	0x39

The MD[3:0] is set by mode table, please refer to page 13.

M-series TFT Commands Reference Guide

(B) Function Setting

6. Brightness of High Byte (BH)

D7	D6	D5	D4	D3	D2	D1	D0	Byte(default)
0	0	0	0	0	0	0	0	0x00

7. Brightness of Low Byte (BL)

D7	D6	D5	D4	D3	D2	D1	D0	Byte(default)
BDL7	BDL6	BDL5	BDL4	BDL3	BDL2	BDL1	BDL0	0x00

Brightness is set by BL[7:0] and BH[7:0].

(C) End Byte

8. End Byte1 (EB1)

D7	D6	D5	D4	D3	D2	D1	D0	Byte(default)
0	0	0	0	1	0	1	0	0x0A

EB1 is instruction ending byte.

9. End Byte2 (EB2)

EB2 is used for check correct instruction, EB2 = last eight bits of sum, which is from SB1 to EB1.

For more detail setting information, please refer to Page 16.

10. End Byte3 (EB3)

D7	D6	D5	D4	D3	D2	D1	D0	Byte(default)
0	0	0	0	1	1	0	1	0x0D

EB3 is package ending byte.

M-series TFT Commands Reference Guide

4.9 TP Compensation Mode

Instruction of Calibration Mode for RTP/CTP

1	2	3	4	5	6	7	8	9	10
SB1	PL	SB2	SB3	MD	BH	BL	EB1	EB2	EB3

4.9.1 Instruction table

No.	Symbol	D7	D6	D5	D4	D3	D2	D1	D0	Describe
1	SB1	0	0	0	0	0	0	0	1	Start Byte
2	PL	PL7	PL6	PL5	PL4	PL3	PL2	PL1	PL0	Package Length
3	SB2	0	0	0	0	0	0	1	0	Start Byte
4	SB3	0	0	0	0	0	1	0	0	Start Byte
5	MD	0	1	1	1	MD3	MD2	MD1	MD0	Mode Selection
8	EB1	0	0	0	0	1	0	1	0	End Byte
9	EB2									
10	EB3	0	0	0	0	1	1	0	1	

M-series TFT Commands Reference Guide

4.9.2 Instruction Describe

(A) Start Byte

1. Start Byte1 (SB1)

D7	D6	D5	D4	D3	D2	D1	D0	Byte
0	0	0	0	0	0	0	1	0x01

Before execute, the SB 1 is used to be start byte of package.

2. Package Length (PL)

D7	D6	D5	D4	D3	D2	D1	D0	Byte
PL7	PL6	PL5	PL4	PL3	PL2	PL1	PL0	0x08

PL[7:0]: The total length of package.

For more information, please refer to page 12.

3. Start Byte2 (SB2)

D7	D6	D5	D4	D3	D2	D1	D0	Byte
0	0	0	0	0	0	1	0	0x02

4. Start Byte3 (SB3)

D7	D6	D5	D4	D3	D2	D1	D0	Byte
0	0	0	0	0	1	0	0	0x04

SB2,3 are used to confirm display size. (Ex: 0x02 and 0x04 are corresponded M-Series TFT'')

5. Mode (MD)

D7	D6	D5	D4	D3	D2	D1	D0	Byte
0	1	1	1	MD3	MD2	MD1	MD0	0x7E

The MD[3:0] is set by mode table, please refer to page 13.

M-series TFT Commands Reference Guide

(C) End Byte

8. End Byte1 (EB1)

D7	D6	D5	D4	D3	D2	D1	D0	Byte(default)
0	0	0	0	1	0	1	0	0x0A

EB1 is instruction ending byte.

9. End Byte2 (EB2)

EB2 is used for check correct instruction, EB2 = last eight bits of sum, which is from SB1 to EB1.

For more detail setting information, please refer to Page 16.

10. End Byte3 (EB3)

D7	D6	D5	D4	D3	D2	D1	D0	Byte(default)
0	0	0	0	1	1	0	1	0x0D

EB3 is package ending byte.

M-series TFT Commands Reference Guide

4.10 TP feedback signal

Instruction of Feedback signal for RTP/CTP

1	2	3	4	5
STX	X point High byte	X point Low byte	Y point High byte	Y point Low byte
0x41	XXh	XXh	XXh	XXh

** The range of XXh is 00h to FFh

The range of X Point is 0 to 800 in decimal

The range of Y Point is 0 to 480 in decimal

Ex1. When the position of X is 150 and Y is 180 in decimal was touched , you'll get the STX(41H) command via Uart/SPI from the module.

STX	X point High byte	X point Low byte	Y point High byte	Y point Low byte
41h	00h	96h	00h	B4h

Ex2. When the position of X is 300 and Y is 100 in decimal was touched , you'll get the STX(41H) command via Uart/SPI from the module.

STX	X point High byte	X point Low byte	Y point High byte	Y point Low byte
41h	01h	2Ch	00h	64h

M-series TFT Commands Reference Guide

4.10.1 SPI interface

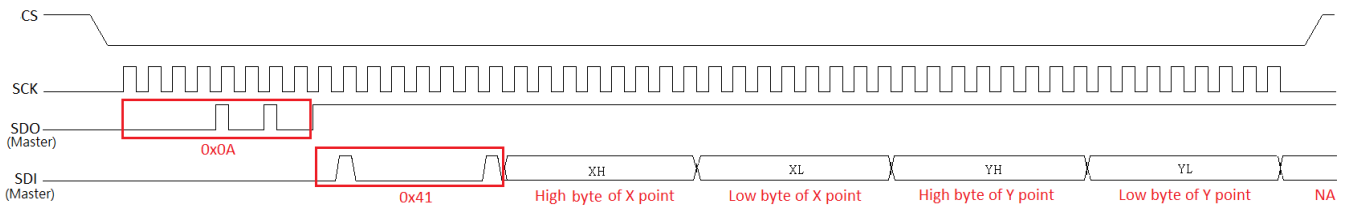
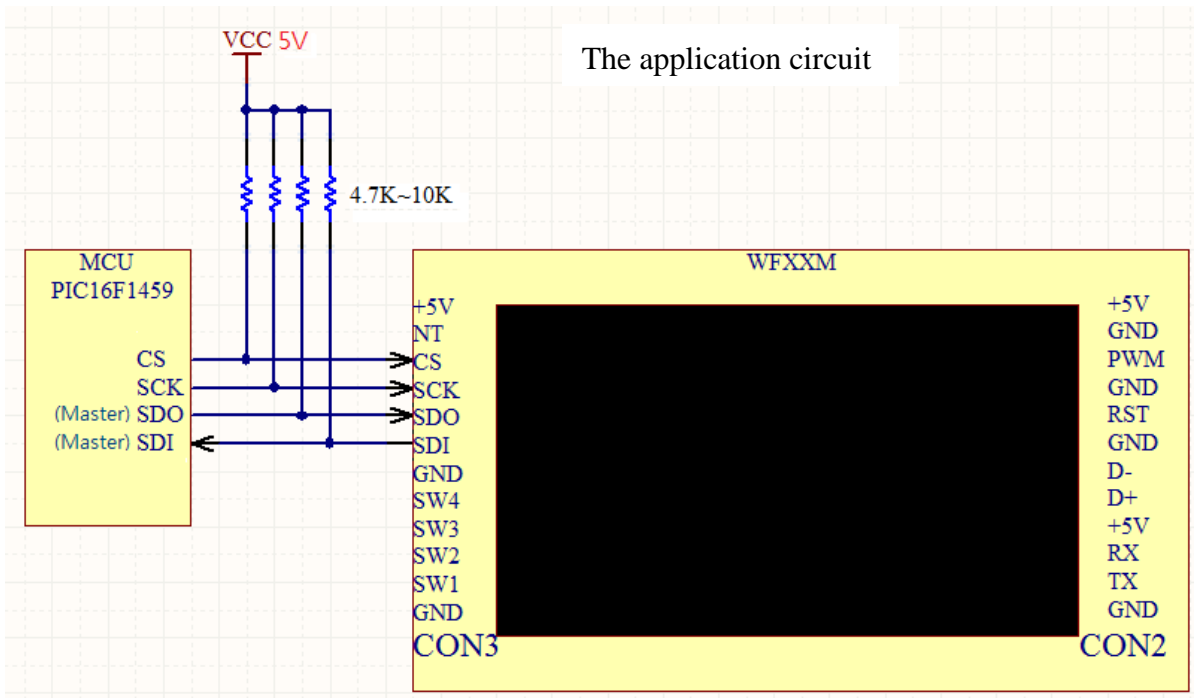

Timing Diagram of Reading TP Register

Busy Flag (BF)

When BF is “High”, it indicates that the internal operation is being processed. So during this time the next instruction cannot be accepted. BF can be read, when send 0x01 command, through D0 bit. Before executing the next instruction, be sure that BF is not High.

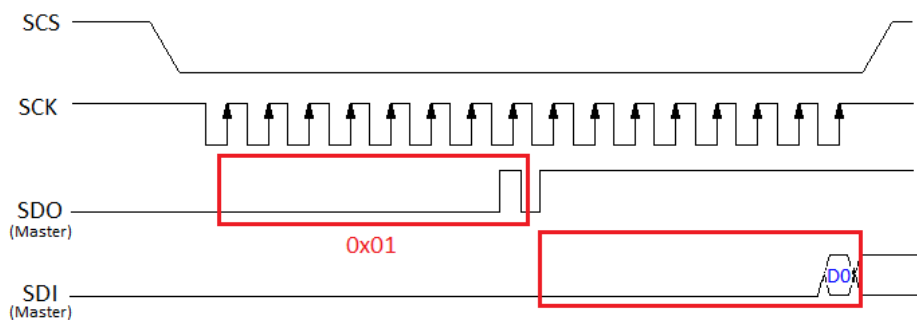

Timing Diagram of Checking Busy

M-series TFT Commands Reference Guide

INT(Serial Interrupt)

N_press: Press and hold the switch or TP for a period.

N1_release: Release the switch or TP.

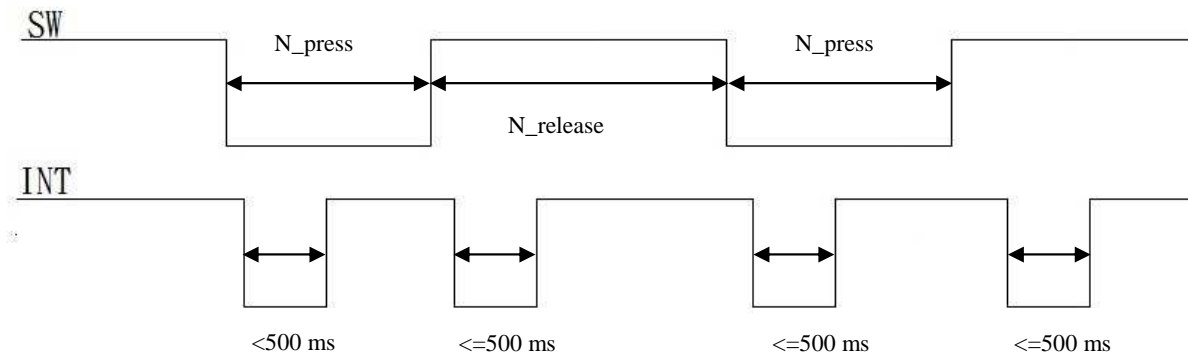

1. When user use SPI interface, the initial status for INT is 1.
2. When they press any button among SW1 to SW4 or TP, INT status will change from 1 to 0. After lasting for 500ms, it will return to 1 automatically. Even though pressing button or TP continuously, INT will return to 1 after 500ms.
3. When they release any button among SW1 to SW4 or TP, INT status will change from 1 to 0.
4. When INT is Low while reading TP register or switch register, INT will return to 1 status immediately. There's no need to wait until 500ms.

Notice:

About TP register, please refer **4.10 TP feedback signal**.

About SW1 to SW4 register, please refer **4.12 Switch Function**.

M-series TFT Commands Reference Guide

4.11 ACK

The ACK Definition

When Clever System M-Series TFT receive an instruction which is sent from MCU, it will send a byte to MCU to confirm whether the module receive correct instruction. If receiving correct instruction, the module will send ACK to MCU, else receiving error instruction, module will send NAK.

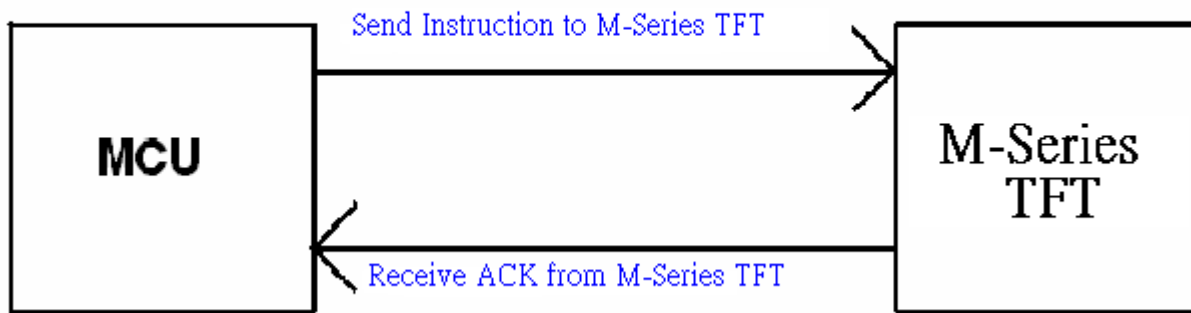

The ACK Process

Step1. MCU send an instruction to M-Series TFT.

Step2. When M-Series TFT completes the executive instruction, it will send ACK or NAK to MCU.

Notice:

If M-Series TFT receive correct instruction, it will send **ACK = 0x06** to MCU.

If M-Series TFT receive error instruction, it will send **NAK = 0x15** to MCU.

M-series TFT Commands Reference Guide

4.12 Switch Function

M-Series TFT provide four GPO Pins for Switch Function, the example switch circuit is below

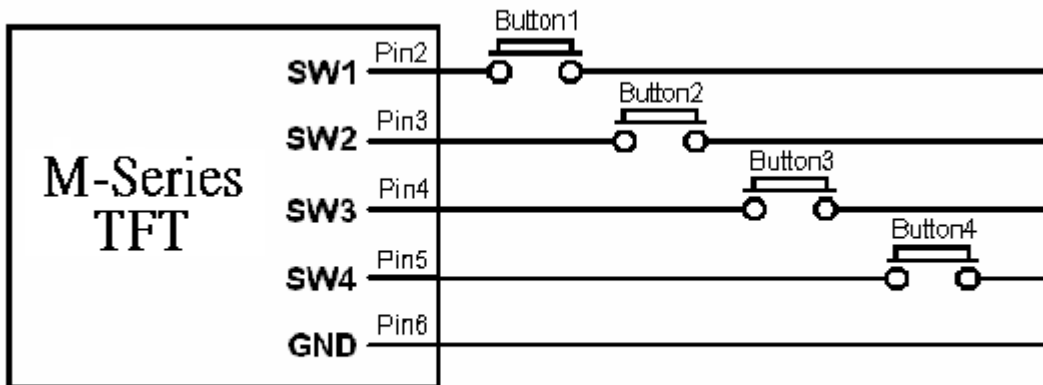

The Switch Process

Step1. User press the button 1 to 4 and the module will receive two bytes. First byte is 0x40 and second byte will be shown in below table.

Press Button		
Switch	First Byte	Second Byte
SW1	0x40	0x41
SW2		0x42
SW3		0x43
SW4		0x44

Step2. User release the button 1 to 4 and the module will receive corresponding byte, see below.

Release Button	
Switch	Byte
SW1	0x20
SW2	
SW3	
SW4	