

DATA SHEET

SURFACE MOUNT MULTILAYER CERAMIC CAPACITORS

Automotive grade

NP0/X7R

6.3 V TO 630 V

0.47 pF to 1 μ F

RoHS compliant & Halogen Free



SCOPE

This specification describes Automotive grade NP0/X7R series chip capacitors with lead-free terminations and used for automotive equipments.

APPLICATIONS

All general purpose applications
 Entertainment applications
 Comfort / security applications
 Information applications

FEATURES

- Comply with AEC-Q200 standard
- MSL class: MSL I
- AC series soldering is compliant with J-STD-020D
- Halogen free epoxy
- RoHS compliant
- Reduce environmentally hazardous waste
- High component and equipment reliability
- Save PCB space
- The capacitors are 100% performed by automatic optical inspection prior to taping.

ORDERING INFORMATION – GLOBAL PART NUMBER

All part numbers are identified by the series, size, tolerance, TC material, packing style, voltage, process code, termination and capacitance value.

GLOBAL PART NUMBER

AC XXXX X X XXX X **B** X XXX
 (1) (2) (3) (4) (5) (6) (7)

(1) SIZE – INCH BASED (METRIC)

0402 (1005) / 0603 (1608) / 0805 (2012) / 1206 (3216) / 1210 (3225) / 0508 (1220) / 0612 (1632)

(2) TOLERANCE

B = ±0.1 pF
 C = ±0.25 pF
 D = ±0.5 pF
 G = ±2%
 J = ±5%
 K = ±10%
 M = ±20%

(3) PACKING STYLE

R = Paper/PE taping reel; Reel 7 inch
 K = Blister taping reel; Reel 7 inch
 P = Paper/PE taping reel; Reel 13 inch
 F = Blister taping reel; Reel 13 inch

(4) TC MATERIAL

NPO
 X7R

(5) RATED VOLTAGE

5 = 6.3 V
 6 = 10 V
 7 = 16 V
 8 = 25 V
 9 = 50 V
 0 = 100 V
 A = 200 V
 Y = 250 V
 B = 500 V
 Z = 630 V

(6) PROCESS

N = NP0
 B = Class 2 MLCC

(7) CAPACITANCE VALUE

2 significant digits+number of zeros
 The 3rd digit signifies the multiplying factor, and letter R is decimal point
 Example: 121 = 12 x 10¹ = 120 pF

CONSTRUCTION

The capacitor consists of a rectangular block of ceramic dielectric in which a number of interleaved metal electrodes are contained. This structure gives rise to a high capacitance per unit volume.

The inner electrodes are connected to the two end terminations and finally covered with a layer of plated tin (Matte Sn). The terminations are lead-free. A cross section of the structure is shown in Fig.1.

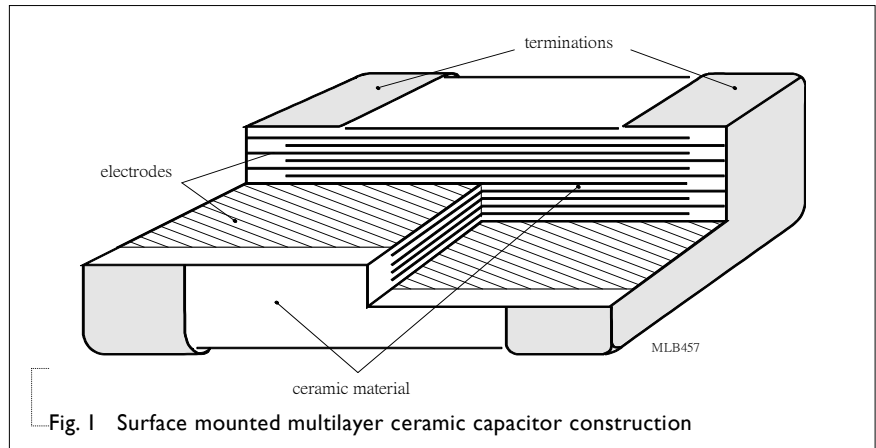

DIMENSION

Table I TYPE	For outlines see fig. 2		T (MM)	L ₂ / L ₃ (mm)		L ₄ (mm)
	L ₁ (mm)	W (mm)		min.	max.	min.
0402	1.0 ±0.05	0.5 ±0.05	Refer to table 3 to 12	0.15	0.30	0.40
0603	1.6 ±0.10	0.8 ±0.10		0.20	0.60	0.40
0805	2.0 ±0.20	1.25 ±0.20		0.25	0.75	1.40
1206	3.2 ±0.30	1.6 ±0.20		0.25	0.75	1.40
1210	3.2 ±0.30	2.5 ±0.20		0.25	0.75	1.40
1812	4.5±0.40	3.2±0.40		0.25	0.75	2.20

OUTLINES

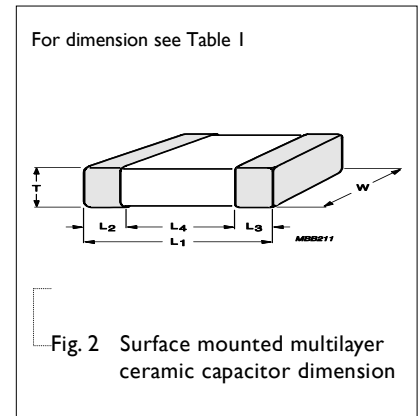

OUTLINES

Table 2 For outlines see fig. 3

TYPE	0508 (4 X 0402)	0612 (4 X 0603)
L (mm)	2.0 ±0.15	3.2 ±0.15
W (mm)	1.25 ±0.15	1.60 ±0.15
T _{min.} (mm)	0.50	0.70
T _{max.} (mm)	0.70	0.90
A (mm)	0.28 ±0.10	0.4 ±0.10
B (mm)	0.2 ±0.10	0.3 ±0.20
P (mm)	0.5 ±0.10	0.8 ±0.10

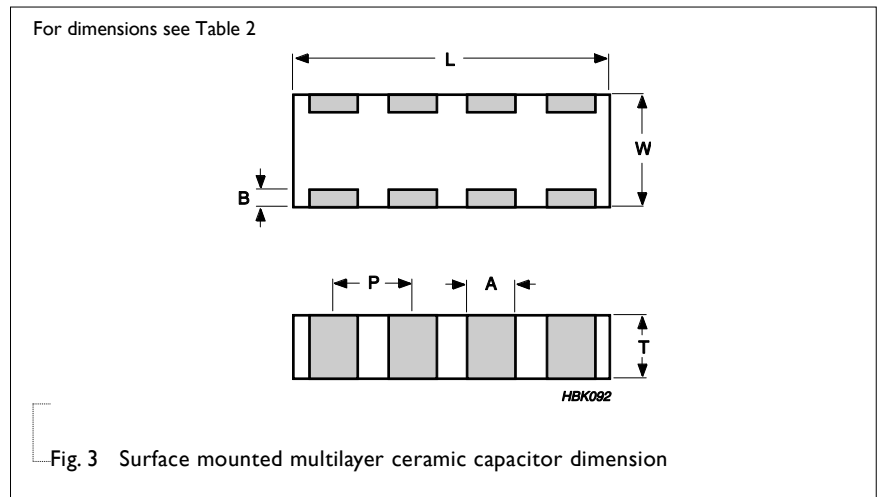

CAPACITANCE RANGE & THICKNESS FOR NP0

Table 3 Sizes from 0402 to 0805

CAP.	0402		0603			0805		
	50 V	50 V	100 V	250 V	50 V	100 V	250 V	
0.47 pF	0.5±0.05	0.8±0.1	0.8±0.1	0.8±0.1	0.6±0.1	0.6±0.1	0.6±0.1	
0.56 pF	0.5±0.05	0.8±0.1	0.8±0.1	0.8±0.1	0.6±0.1	0.6±0.1	0.6±0.1	
0.68 pF	0.5±0.05	0.8±0.1	0.8±0.1	0.8±0.1	0.6±0.1	0.6±0.1	0.6±0.1	
0.82 pF	0.5±0.05	0.8±0.1	0.8±0.1	0.8±0.1	0.6±0.1	0.6±0.1	0.6±0.1	
1.0 pF	0.5±0.05	0.8±0.1	0.8±0.1	0.8±0.1	0.6±0.1	0.6±0.1	0.6±0.1	
1.2 pF	0.5±0.05	0.8±0.1	0.8±0.1	0.8±0.1	0.6±0.1	0.6±0.1	0.6±0.1	
1.5 pF	0.5±0.05	0.8±0.1	0.8±0.1	0.8±0.1	0.6±0.1	0.6±0.1	0.6±0.1	
1.8 pF	0.5±0.05	0.8±0.1	0.8±0.1	0.8±0.1	0.6±0.1	0.6±0.1	0.6±0.1	
2.2 pF	0.5±0.05	0.8±0.1	0.8±0.1	0.8±0.1	0.6±0.1	0.6±0.1	0.6±0.1	
2.7 pF	0.5±0.05	0.8±0.1	0.8±0.1	0.8±0.1	0.6±0.1	0.6±0.1	0.6±0.1	
3.3 pF	0.5±0.05	0.8±0.1	0.8±0.1	0.8±0.1	0.6±0.1	0.6±0.1	0.6±0.1	
3.9 pF	0.5±0.05	0.8±0.1	0.8±0.1	0.8±0.1	0.6±0.1	0.6±0.1	0.6±0.1	
4.7 pF	0.5±0.05	0.8±0.1	0.8±0.1	0.8±0.1	0.6±0.1	0.6±0.1	0.6±0.1	
5.6 pF	0.5±0.05	0.8±0.1	0.8±0.1	0.8±0.1	0.6±0.1	0.6±0.1	0.6±0.1	
6.8 pF	0.5±0.05	0.8±0.1	0.8±0.1	0.8±0.1	0.6±0.1	0.6±0.1	0.6±0.1	
8.2 pF	0.5±0.05	0.8±0.1	0.8±0.1	0.8±0.1	0.6±0.1	0.6±0.1	0.6±0.1	
10 pF	0.5±0.05	0.8±0.1	0.8±0.1	0.8±0.1	0.6±0.1	0.6±0.1	0.6±0.1	
12 pF	0.5±0.05	0.8±0.1	0.8±0.1	0.8±0.1	0.6±0.1	0.6±0.1	0.6±0.1	
15 pF	0.5±0.05	0.8±0.1	0.8±0.1	0.8±0.1	0.6±0.1	0.6±0.1	0.6±0.1	
18 pF	0.5±0.05	0.8±0.1	0.8±0.1	0.8±0.1	0.6±0.1	0.6±0.1	0.6±0.1	
22 pF	0.5±0.05	0.8±0.1	0.8±0.1	0.8±0.1	0.6±0.1	0.6±0.1	0.6±0.1	
27 pF	0.5±0.05	0.8±0.1	0.8±0.1	0.8±0.1	0.6±0.1	0.6±0.1	0.6±0.1	
33 pF	0.5±0.05	0.8±0.1	0.8±0.1	0.8±0.1	0.6±0.1	0.6±0.1	0.6±0.1	
39 pF	0.5±0.05	0.8±0.1	0.8±0.1	0.8±0.1	0.6±0.1	0.6±0.1	0.6±0.1	
47 pF	0.5±0.05	0.8±0.1	0.8±0.1	0.8±0.1	0.6±0.1	0.6±0.1	0.6±0.1	
56 pF	0.5±0.05	0.8±0.1	0.8±0.1	0.8±0.1	0.6±0.1	0.6±0.1	0.6±0.1	
68 pF	0.5±0.05	0.8±0.1	0.8±0.1	0.8±0.1	0.6±0.1	0.6±0.1	0.6±0.1	
82 pF	0.5±0.05	0.8±0.1	0.8±0.1	0.8±0.1	0.6±0.1	0.6±0.1	0.6±0.1	
100 pF	0.5±0.05	0.8±0.1	0.8±0.1	0.8±0.1	0.6±0.1	0.6±0.1	0.6±0.1	

NOTE

I. Values in shaded cells indicate thickness class in mm

CAPACITANCE RANGE & THICKNESS FOR NP0

Table 4 Sizes from 0402 to 0805 (continued)

CAP.	0402	0603			0805		
	50 V	50 V	100 V	250 V	50 V	100 V	250 V
120 pF	0.5±0.05	0.8±0.1	0.8±0.1	0.8±0.1	0.6±0.1	0.6±0.1	0.6±0.1
150 pF	0.5±0.05	0.8±0.1	0.8±0.1	0.8±0.1	0.6±0.1	0.6±0.1	0.6±0.1
180 pF	0.5±0.05	0.8±0.1	0.8±0.1	0.8±0.1	0.6±0.1	0.6±0.1	0.6±0.1
220 pF	0.5±0.05	0.8±0.1	0.8±0.1	0.8±0.1	0.6±0.1	0.6±0.1	0.85±0.1
270 pF		0.8±0.1	0.8±0.1	0.8±0.1	0.6±0.1	0.6±0.1	0.85±0.1
330 pF		0.8±0.1	0.8±0.1	0.8±0.1	0.6±0.1	0.6±0.1	0.85±0.1
390 pF		0.8±0.1	0.8±0.1	0.8±0.1	0.6±0.1	0.6±0.1	0.85±0.1
470 pF		0.8±0.1	0.8±0.1	0.8±0.1	0.6±0.1	0.6±0.1	0.85±0.1
560 pF		0.8±0.1	0.8±0.1	0.8±0.1	0.6±0.1	0.85±0.1	0.85±0.1
680 pF		0.8±0.1	0.8±0.1	0.8±0.1	0.6±0.1	0.85±0.1	0.85±0.1
820 pF					0.6±0.1	0.85±0.1	0.85±0.1
1.0 nF					0.6±0.1	0.85±0.1	0.85±0.1
1.2 nF							
1.5 nF							
1.8 nF							
2.2 nF							
2.7 nF							
3.3 nF							
3.9 nF							
4.7 nF							
5.6 nF							
6.8 nF							
8.2 nF							
10 nF							

NOTE

Values in shaded cells indicate thickness class in mm

Remark: AC0805xRNPO09N561~102

CAPACITANCE RANGE & THICKNESS FOR NP0

Table 5 Sizes from 1206 to 1210

CAP.	1206					1210			
	50 V	100 V	250 V	500 V	630 V	50 V	100 V	250 V	500 V
10 pF	0.6±0.1	0.6±0.1	0.6±0.1	0.6±0.1	1.25±0.2				
12 pF	0.6±0.1	0.6±0.1	0.6±0.1	0.6±0.1	1.25±0.2				
15 pF	0.6±0.1	0.6±0.1	0.6±0.1	0.6±0.1	1.25±0.2				
18 pF	0.6±0.1	0.6±0.1	0.6±0.1	0.6±0.1	1.25±0.2				
22 pF	0.6±0.1	0.6±0.1	0.6±0.1	0.6±0.1	1.25±0.2				
27 pF	0.6±0.1	0.6±0.1	0.6±0.1	0.6±0.1	1.25±0.2				
33 pF	0.6±0.1	0.6±0.1	0.6±0.1	0.6±0.1	1.25±0.2				
39 pF	0.6±0.1	0.6±0.1	0.6±0.1	0.6±0.1	1.25±0.2				
47 pF	0.6±0.1	0.6±0.1	0.6±0.1	0.6±0.1	1.25±0.2				
56 pF	0.6±0.1	0.6±0.1	0.6±0.1	0.6±0.1	1.25±0.2				
68 pF	0.6±0.1	0.6±0.1	0.6±0.1	0.6±0.1	1.25±0.2				
82 pF	0.6±0.1	0.6±0.1	0.6±0.1	0.6±0.1	1.25±0.2				
100 pF	0.6±0.1	0.6±0.1	0.6±0.1	0.6±0.1	1.25±0.2				
120 pF	0.6±0.1	0.6±0.1	0.6±0.1	0.6±0.1	1.25±0.2				
150 pF	0.6±0.1	0.6±0.1	0.6±0.1	0.6±0.1	1.25±0.2				
180 pF	0.6±0.1	0.6±0.1	0.6±0.1	0.6±0.1	1.25±0.2				
220 pF	0.6±0.1	0.6±0.1	0.6±0.1	0.6±0.1	1.25±0.2				
270 pF	0.6±0.1	0.6±0.1	0.6±0.1	0.6±0.1	1.25±0.2				
330 pF	0.6±0.1	0.6±0.1	0.6±0.1	0.6±0.1	1.25±0.2				
390 pF	0.6±0.1	0.6±0.1	0.6±0.1	0.6±0.1	1.25±0.2				
470 pF	0.6±0.1	0.6±0.1	0.6±0.1	0.6±0.1	1.25±0.2				
560 pF	0.6±0.1	0.6±0.1	0.6±0.1	0.6±0.1	1.25±0.2				
680 pF	0.6±0.1	0.6±0.1	0.6±0.1	0.6±0.1	1.25±0.2				
820 pF	0.6±0.1	0.6±0.1	0.85±0.1	0.85±0.1	1.25±0.2				
1.0 nF	0.6±0.1	0.6±0.1	0.85±0.1	0.85±0.1	1.25±0.2	1.25±0.2	1.25±0.2	1.25±0.2	1.25±0.2
1.2 nF	0.6±0.1	0.6±0.1				1.25±0.2	1.25±0.2	1.25±0.2	1.25±0.2
1.5 nF	0.6±0.1	0.6±0.1				1.25±0.2	1.25±0.2	1.25±0.2	1.25±0.2
1.8 nF	0.6±0.1	0.6±0.1				1.25±0.2	1.25±0.2	1.25±0.2	1.25±0.2
2.2 nF	0.6±0.1	0.6±0.1				1.25±0.2	1.25±0.2	1.25±0.2	
2.7 nF	0.6±0.1	0.6±0.1				1.25±0.2	1.25±0.2	1.25±0.2	
3.3 nF									
3.9 nF									
4.7 nF									
5.6 nF									
6.8 nF									
8.2 nF									
10 nF									

NOTE

Values in shaded cells indicate thickness class in mm

CAPACITANCE RANGE & THICKNESS FOR X7R

Table 6 Sizes from 0402 to 0603

CAP.	0402				0603				
	10V	16 V	25 V	50 V	10V	16 V	25 V	50 V	100 V
100 pF									
150 pF									
220 pF	0.5±0.05	0.5±0.05	0.5±0.05	0.5±0.05					
330 pF	0.5±0.05	0.5±0.05	0.5±0.05	0.5±0.05					
470 pF	0.5±0.05	0.5±0.05	0.5±0.05	0.5±0.05					
680 pF	0.5±0.05	0.5±0.05	0.5±0.05	0.5±0.05					
1.0 nF	0.5±0.05	0.5±0.05	0.5±0.05	0.5±0.05	0.8±0.1	0.8±0.1	0.8±0.1	0.8±0.1	0.8±0.1
1.5 nF	0.5±0.05	0.5±0.05	0.5±0.05	0.5±0.05	0.8±0.1	0.8±0.1	0.8±0.1	0.8±0.1	0.8±0.1
2.2 nF	0.5±0.05	0.5±0.05	0.5±0.05	0.5±0.05	0.8±0.1	0.8±0.1	0.8±0.1	0.8±0.1	0.8±0.1
3.3 nF	0.5±0.05	0.5±0.05	0.5±0.05	0.5±0.05	0.8±0.1	0.8±0.1	0.8±0.1	0.8±0.1	0.8±0.1
4.7 nF	0.5±0.05	0.5±0.05	0.5±0.05	0.5±0.05	0.8±0.1	0.8±0.1	0.8±0.1	0.8±0.1	0.8±0.1
6.8 nF	0.5±0.05	0.5±0.05	0.5±0.05	0.5±0.05	0.8±0.1	0.8±0.1	0.8±0.1	0.8±0.1	0.8±0.1
10 nF	0.5±0.05	0.5±0.05	0.5±0.05	0.5±0.05	0.8±0.1	0.8±0.1	0.8±0.1	0.8±0.1	0.8±0.1
15 nF	0.5±0.05	0.5±0.05	0.5±0.05		0.8±0.1	0.8±0.1	0.8±0.1	0.8±0.1	0.8±0.1
22 nF	0.5±0.05	0.5±0.05	0.5±0.05		0.8±0.1	0.8±0.1	0.8±0.1	0.8±0.1	0.8±0.1
33 nF	0.5±0.05	0.5±0.05	0.5±0.05		0.8±0.1	0.8±0.1	0.8±0.1	0.8±0.1	0.8±0.1
47 nF	0.5±0.05	0.5±0.05	0.5±0.05		0.8±0.1	0.8±0.1	0.8±0.1	0.8±0.1	0.8±0.1
68 nF	0.5±0.05	0.5±0.05			0.8±0.1	0.8±0.1	0.8±0.1	0.8±0.1	
100 nF	0.5±0.05	0.5±0.05			0.8±0.1	0.8±0.1	0.8±0.1	0.8±0.1	
150 nF					0.8±0.1	0.8±0.1			
220 nF					0.8±0.1	0.8±0.1			
330 nF									
470 nF									
680 nF									
1 μF									

NOTE

Values in shaded cells indicate thickness class in mm

CAPACITANCE RANGE & THICKNESS FOR X7R

Table 8 Size 0805

CAP.	0805						
	10 V	16 V	25 V	50 V	100 V	250 V	500 V
100 pF							
150 pF							
220 pF							
330 pF							
470 pF							
680 pF							
1.0 nF	0.85±0.1	0.85±0.1	0.85±0.1	0.85±0.1	0.85±0.1	0.85±0.1	0.85±0.1
1.5 nF	0.85±0.1	0.85±0.1	0.85±0.1	0.85±0.1	0.85±0.1	0.85±0.1	0.85±0.1
2.2 nF	0.85±0.1	0.85±0.1	0.85±0.1	0.85±0.1	0.85±0.1	0.85±0.1	0.85±0.1
3.3 nF	0.85±0.1	0.85±0.1	0.85±0.1	0.85±0.1	0.85±0.1	0.85±0.1	0.85±0.1
4.7 nF	0.85±0.1	0.85±0.1	0.85±0.1	0.85±0.1	0.85±0.1	0.85±0.1	0.85±0.1
6.8 nF	0.85±0.1	0.85±0.1	0.85±0.1	0.85±0.1	0.85±0.1	1.25±0.2	
10 nF	0.85±0.1	0.85±0.1	0.85±0.1	0.85±0.1	0.85±0.1	1.25±0.2	
15 nF	0.85±0.1	0.85±0.1	0.85±0.1	0.85±0.1	0.85±0.1	1.25±0.2	
22 nF	0.85±0.1	0.85±0.1	0.85±0.1	0.85±0.1	0.85±0.1	1.25±0.2	
33 nF	0.85±0.1	0.85±0.1	0.85±0.1	0.85±0.1	1.25±0.2		
47 nF	0.85±0.1	0.85±0.1	0.85±0.1	0.85±0.1	1.25±0.2		
68 nF	0.85±0.1	0.85±0.1	0.85±0.1	0.85±0.1	1.25±0.2		
100 nF	0.85±0.1	0.85±0.1	0.85±0.1	0.85±0.1	1.25±0.2		
150 nF	1.25±0.2	1.25±0.2	1.25±0.2	0.85±0.1			
220 nF	1.25±0.2	1.25±0.2	1.25±0.2	1.25±0.2			
330 nF	1.25±0.2	1.25±0.2	1.25±0.2				
470 nF	1.25±0.2	1.25±0.2	1.25±0.2				
680 nF	1.25±0.2	1.25±0.2	1.25±0.2				
1 µF	1.25±0.2	1.25±0.2	1.25±0.2				
2.2 µF							

NOTE

Values in shaded cells indicate thickness class in mm

CAPACITANCE RANGE & THICKNESS FOR X7R

Table 9 Size 1206

CAP.	1206						
	6.3 V	10V	16V	25V	50 V	100 V	250 V
22 nF	0.85±0.1	0.85±0.1	0.85±0.1	0.85±0.1	0.85±0.1	0.85±0.1	1.25±0.2
33 nF	0.85±0.1	0.85±0.1	0.85±0.1	0.85±0.1	0.85±0.1	0.85±0.1	
47 nF	0.85±0.1	0.85±0.1	0.85±0.1	0.85±0.1	0.85±0.1	0.85±0.1	
68 nF	0.85±0.1	0.85±0.1	0.85±0.1	0.85±0.1	0.85±0.1	1.25±0.2	
100 nF	0.85±0.1	0.85±0.1	0.85±0.1	0.85±0.1	0.85±0.1	1.25±0.2	
150 nF	0.85±0.1	0.85±0.1	0.85±0.1	0.85±0.1	1.15±0.1	1.25±0.2	
220 nF	0.85±0.1	0.85±0.1	0.85±0.1	0.85±0.1	1.15±0.1	1.25±0.2	
330 nF	0.85±0.1	0.85±0.1	0.85±0.1	0.85±0.1	1.6±0.2		
470 nF	1.00±0.1	1.00±0.1	1.00±0.1	1.00±0.1	1.6±0.2		
680 nF	1.15±0.1	1.15±0.1	1.15±0.1	1.6±0.2*			
1 μF	1.15±0.1	1.15±0.1	1.15±0.1	1.6±0.2*			

NOTE

Values in shaded cells indicate thickness class in mm

Remark: AC1206xKX7R8CB684~105

CAPACITANCE RANGE & THICKNESS FOR X7R

Table 10 Size 1210

CAP.	1210							1812	
	6.3V	10 V	16 V	25 V	50V	100 V	250 V	50V	100V
100 nF	0.85±0.1	0.85±0.1	0.85±0.1	0.85±0.1	0.85±0.1	0.85±0.1	1.25±0.2		
150 nF	0.85±0.1	0.85±0.1	0.85±0.1	0.85±0.1	1.15±0.1	1.25±0.2			
220 nF	0.85±0.1	0.85±0.1	0.85±0.1	0.85±0.1	1.15±0.1	1.25±0.2			
330 nF	0.85±0.1	0.85±0.1	0.85±0.1	0.85±0.1	1.15±0.1				
470 nF	1.25±0.2	1.25±0.2	1.25±0.2	1.25±0.2	1.25±0.2			1.60±0.2	1.60±0.2
680 nF	1.25±0.2	1.25±0.2	1.25±0.2	1.25±0.2	1.25±0.2			1.60±0.2	1.60±0.2
1 µF	1.25±0.2	1.25±0.2	1.25±0.2	1.25±0.2	1.25±0.2			1.60±0.2	1.60±0.2

NOTE

Values in shaded cells indicate thickness class in mm

CAPACITANCE RANGE & THICKNESS FOR 4C-ARRAY

Table 11 Temperature characteristic material from NP0

CAPACITANCE	0508 (4 x 0402)	0612 (4 x 0603)
	50 V	50 V
10 pF	0.6±0.1	0.8±0.1
15 pF	0.6±0.1	0.8±0.1
18 pF	0.6±0.1	0.8±0.1
22 pF	0.6±0.1	0.8±0.1
33 pF	0.6±0.1	0.8±0.1
39 pF	0.6±0.1	0.8±0.1
47 pF	0.6±0.1	0.8±0.1
56 pF	0.6±0.1	0.8±0.1
68 pF	0.6±0.1	0.8±0.1
82 pF	0.6±0.1	0.8±0.1
100 pF	0.6±0.1	0.8±0.1
120 pF		0.8±0.1
150 pF		0.8±0.1
180 pF		0.8±0.1
220 pF		0.8±0.1
270 pF		0.8±0.1
330 pF		0.8±0.1
390 pF		0.8±0.1
470 pF		0.8±0.1
560 pF		
680 pF		
820 pF		
1.0 nF		

NOTE

Values in shaded cells indicate thickness class in mm

CAPACITANCE RANGE & THICKNESS FOR 4C-ARRAY

Table 12 Temperature characteristic material from X7R

CAPACITANCE	0508 (4 x 0402)			0612 (4 x 0603)		
	16 V	25 V	50 V	16 V	25 V	50 V
220 pF				0.8±0.1	0.8±0.1	0.8±0.1
330 pF				0.8±0.1	0.8±0.1	0.8±0.1
470 pF				0.8±0.1	0.8±0.1	0.8±0.1
680 pF				0.8±0.1	0.8±0.1	0.8±0.1
1.0 nF	0.6±0.1	0.6±0.1	0.6±0.1	0.8±0.1	0.8±0.1	0.8±0.1
1.5 nF	0.6±0.1	0.6±0.1		0.8±0.1	0.8±0.1	0.8±0.1
2.2 nF	0.6±0.1	0.6±0.1		0.8±0.1	0.8±0.1	0.8±0.1
3.3 nF	0.6±0.1	0.6±0.1		0.8±0.1	0.8±0.1	0.8±0.1
4.7 nF	0.6±0.1	0.6±0.1		0.8±0.1	0.8±0.1	0.8±0.1
6.8 nF	0.6±0.1	0.6±0.1		0.8±0.1	0.8±0.1	0.8±0.1
10 nF	0.6±0.1			0.8±0.1	0.8±0.1	0.8±0.1
15 nF	0.6±0.1			0.8±0.1	0.8±0.1	
22 nF	0.6±0.1			0.8±0.1	0.8±0.1	
33 nF	0.6±0.1			0.8±0.1	0.8±0.1	
47 nF	0.6±0.1			0.8±0.1	0.8±0.1	
68 nF	0.6±0.1					
100 nF	0.6±0.1					

NOTE

Values in shaded cells indicate thickness class in mm

THICKNESS CLASSES AND PACKING QUANTITY

Table 13

SIZE CODE	THICKNESS CLASSIFICATION	TAPE WIDTH QUANTITY PER REEL	Ø180 MM / 7 INCH		Ø330 MM / 13 INCH	
			Paper	Blister	Paper	Blister
0402	0.5 ±0.05 mm	8 mm	10,000	---	50,000	---
0603	0.8 ±0.1 mm	8 mm	4,000	---	15,000	---
0805/0508	0.6 ±0.1 mm	8 mm	4,000	---	20,000	---
	0.85 ±0.1 mm	8 mm	4,000	---	15,000	---
	1.25 ±0.2 mm	8 mm	---	3,000	---	10,000
1206/0612	0.6 ±0.1 mm	8 mm	4,000	---	20,000	---
	0.85 ±0.1 mm	8 mm	4,000	---	15,000	---
	1.0/1.15 ±0.1 mm	8 mm	---	3,000	---	10,000
	1.25 ±0.2 mm	8 mm	---	3,000	---	10,000
	1.6 ±0.2 mm	8 mm	---	2,000	---	10,000
1210	0.85 ±0.1 mm	8 mm	---	4,000	---	10,000
	1.15 ±0.1 mm	8 mm	---	3,000	---	10,000
	1.25 ±0.2 mm	8 mm	---	3,000	---	10,000
1812	0.6 / 0.85±0.1 mm	12 mm	---	2,000	---	---
	1.15±0.1 mm	12 mm	---	1,000	---	---
	1.25±0.2 mm	12 mm	---	1,000	---	---

ELECTRICAL CHARACTERISTICS
NP0/X7R DIELECTRIC CAPACITORS; NI/SIN TERMINATIONS

Unless otherwise specified, all test and measurements shall be made under standard atmospheric conditions for testing as given in 5.3 of IEC 60068-1:

- Temperature: 15 °C to 35 °C
- Relative humidity: 25% to 75%
- Air pressure: 86 kPa to 106 kPa

Before the measurements are made, the capacitor shall be stored at the measuring temperature for a time sufficient to allow the entire capacitor to reach this temperature.

The period as prescribed for recovery at the end of a test is normally sufficient for this purpose.

Table 14

DESCRIPTION		VALUE
Capacitance range		0.47 pF to 1 μF
Capacitance tolerance		
NP0	C < 10 pF	±0.25 pF, ±0.5 pF
	C ≥ 10 pF	±2%, ±5%
X7R		±5% ⁽¹⁾ , ±10%, ±20%
Dissipation factor (D.F.)		
NP0	C < 30 pF	≤ 1 / (400 + 20C)
	C ≥ 30 pF	≤ 0.1 %
X7R	≤ 10 V	≤ 5 %
	16 V	≤ 2.5 %
	Exception: 0402 ≥ 27 nF; 0603 ≥ 220 nF; 0805 ≥ 680 nF	≤ 5 %
	25 V	≤ 2.5 %
	Exception: 0402 ≥ 10 nF; 0603 ≥ 47 nF; 0805 ≥ 220 nF; 1206 ≥ 1 μF	≤ 3.5 %
	Exception: 0402 ≥ 56 nF; 0805 ≥ 680 nF	≤ 5 %
≥ 50 V		≤ 2.5 %
	Exception: 0603 ≥ 47 nF	≤ 3.0 %
Insulation resistance after 1 minute at U _r (DC)		IR ≥ 10 GΩ or I.R × C ≥ 500 seconds whichever is less
Maximum capacitance change as a function of temperature (temperature characteristic/coefficient):		
NP0		±30 ppm/°C
X7R		±15%
Operating temperature range:		
NP0/X7R		-55 °C to +125 °C

NOTE

1. Capacitance tolerance ±5% doesn't available for X7R full product range, please contact local sales force before order

SOLDERING RECOMMENDATION

Table 15

SOLDERING METHOD	SIZE				
	0402	0603	0805	1206	≥ 1210
Reflow	≥ 0.1 μF	≥ 1.0 μF	≥ 2.2 μF	≥ 4.7 μF	Reflow only
Reflow/Wave	< 0.1 μF	< 1.0 μF	< 2.2 μF	< 4.7 μF	---

TESTS AND REQUIREMENTS

Table 16 Test procedures and requirements

TEST	TEST METHOD	PROCEDURE	REQUIREMENTS
Mounting	IEC 60384-21/22	4.3 The capacitors may be mounted on printed-circuit boards or ceramic substrates	No visible damage
Capacitance	IEC 60384-21/22	4.5.1 Class 1: At 20 °C, 24 hours after annealing f = 1 MHz for C ≤ 1nF, measuring at voltage V _{rms} at 20 °C f = 1 KHz for C > 1nF, measuring at voltage V _{rms} at 20 °C Class 2: At 20 °C, 24 hours after annealing f = 1 KHz, measuring at voltage V _{rms} at 20 °C	Within specified tolerance
Dissipation Factor (D.F.)	IEC 60384-21/22	4.5.2 Class 1: At 20 °C, 24 hours after annealing f = 1 MHz for C ≤ 1nF, measuring at voltage V _{rms} at 20 °C f = 1 KHz for C > 1nF, measuring at voltage V _{rms} at 20 °C Class 2: At 20 °C, 24 hours after annealing f = 1 KHz, measuring at voltage V _{rms} at 20 °C	In accordance with specification
Insulation Resistance	IEC 60384-21/22	4.5.3 At U _r (DC) for 1 minute	In accordance with specification

TEST	TEST METHOD	PROCEDURE	REQUIREMENTS												
Temperature coefficient	4.6	<p>Capacitance shall be measured by the steps shown in the following table.</p> <p>The capacitance change should be measured after 5 min at each specified temperature stage.</p> <table border="1" style="margin-left: 20px;"> <thead> <tr> <th>Step</th> <th>Temperature(°C)</th> </tr> </thead> <tbody> <tr> <td>a</td> <td>25±2</td> </tr> <tr> <td>b</td> <td>Lower temperature±3°C</td> </tr> <tr> <td>c</td> <td>25±2</td> </tr> <tr> <td>d</td> <td>Upper Temperature±2°C</td> </tr> <tr> <td>e</td> <td>25±2</td> </tr> </tbody> </table> <p>(1) Class I</p> <p>Temperature Coefficient shall be calculated from the formula as below</p> $\text{Temp. Coefficient} = \frac{C2 - C1}{C1 \times \Delta T} \times 10^6 \text{ [ppm/°C]}$ <p>C1: Capacitance at step c C2: Capacitance at 125°C ΔT: 100°C(=125°C-25°C)</p> <p>(2) Class II</p> <p>Capacitance Change shall be calculated from the formula as below</p> $\Delta C = \frac{C2 - C1}{C1} \times 100\%$ <p>C1: Capacitance at step c C2: Capacitance at step b or d</p>	Step	Temperature(°C)	a	25±2	b	Lower temperature±3°C	c	25±2	d	Upper Temperature±2°C	e	25±2	<p><General purpose series> Class I: Δ C/C: ±30ppm</p> <p>Class2: X7R: Δ C/C: ±15%</p> <p><High Capacitance series> Class2: X7R/X5R: Δ C/C: ±15%</p>
Step	Temperature(°C)														
a	25±2														
b	Lower temperature±3°C														
c	25±2														
d	Upper Temperature±2°C														
e	25±2														
High Temperature Exposure	AEC-Q200 3	<p>Unpowered ; 1000hours @ T=150°C</p> <p>Measurement at 24±2 hours after test conclusion.</p>	<p>No visual damage</p> <p>Δ C/C :</p> <p>Class I: NP0: within ±0.5% or 0.5 pF whichever is greater</p> <p>Class2: X7R: ±10%</p> <p>D.F.: within initial specified value</p> <p>IR: within initial specified value</p>												

TEST	TEST METHOD	PROCEDURE	REQUIREMENTS
Temperature Cycling	AEC-Q200 4	<p>Preconditioning: 150 +0/-10 °C for 1 hour, then keep for 24 ±1 hours at room temperature</p> <p>1000 cycles with following detail: 30 minutes at lower category temperature 30 minutes at upper category temperature</p> <p>Recovery time 24 ±2 hours</p>	<p>No visual damage</p> <hr/> <p>ΔC/C</p> <p>Class I: NP0: Within ±1% or 0.5pF, whichever is greater.</p> <p>Class 2: X7R: ±10%</p> <hr/> <p>D.F. meet initial specified value</p> <hr/> <p>IR meet initial specified value</p>
Destructive Physical Analysis	AEC-Q200 5	<p>10ea X 3 lots.</p> <p>Note: Only applies to SMD ceramics. Electrical test not required.</p>	
Moisture Resistance	AEC-Q200 6	<p>T=24 hrs/per cycle; 10 continuous cycles unpowered. Measurement at 24 ±2 hours after test condition.</p>	<p>No visual damage</p> <hr/> <p>ΔC/C</p> <p>NP0: Within ±3% or 3 pF, whichever is greater</p> <p>X7R: ±10%</p> <hr/> <p>D.F.</p> <p>Within initial specified value</p> <p>IR</p> <p>NP0: ≥ 10,000 MΩ</p> <p>X7R: Meet initial specified value</p>

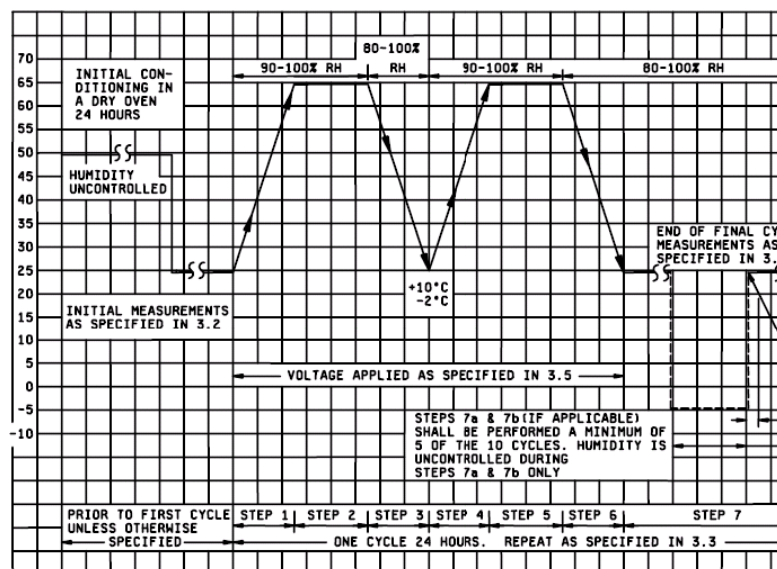

Fig. 4 Moisture resistant

TEST	TEST METHOD	PROCEDURE	REQUIREMENTS
Biased Humidity	AEC-Q200 7	<ol style="list-style-type: none"> 1. Preconditioning, class 2 only: 150 +/-10 °C /1 hour, then keep for 24 ±1 hour at room temp 2. Initial measure: Parameter: IR Measuring voltage: 1.5V ± 0.1 VDC Note: Series with 100 KΩ & 6.8 KΩ 3. Test condition: 85 °C, 85% R.H. connected with 100 KΩ resistor, applied 1.5V/U_r for 1,000 hours. 4. Recovery: Class1: 6 to 24 hours Class2: 24 ±2 hours 5. Final measure: IR 	<p>No visual damage after recovery</p> <hr/> <p>Initial requirement:</p> <p>Class 1:</p> <ul style="list-style-type: none"> - Connected to 100 KΩ: C ≤ 10 nF: I.R ≥ 10,000 MΩ or C > 10 nF: (I.R-100 KΩ) x C ≥ 100s. - Connected to 6.8 KΩ: C ≤ 10 nF: I.R ≥ 10,000 MΩ or C > 10 nF: (I.R-6.8 KΩ) x C ≥ 100s. <p>Class2:</p> <ul style="list-style-type: none"> - Connected to 100 KΩ: C ≤ 25 nF: I.R ≥ 4,000 MΩ or C > 25 nF: (I.R-100 KΩ) x C ≥ 100s. - Connected to 6.8 KΩ: C ≤ 25 nF: I.R ≥ 10,000 MΩ or C > 25 nF: (I.R-6.8 KΩ) x C ≥ 100s. <p>Final measurement:</p> <p>The insulation resistance shall be greater than 0.1 time initial value.</p>

TEST	TEST METHOD		PROCEDURE	REQUIREMENTS
Operational Life	AEC-Q200	8	<p>1. Preconditioning, class 2 only: 150 +0/-10 °C /1 hour, then keep for 24 ±1 hour at room temp</p> <p>2. Initial measure: Spec: refer to initial spec C, D, IR</p> <p>3. Endurance test: Temperature: X7R: 125 °C Specified stress voltage applied for 1,000 hours: Applied 2.0 x U_r for general products Applied 1.5 x U_r for high cap. Products High voltage series follows with below stress condition: Applied 1.5 x U_r for 200V, 250V series Applied 1.3 x U_r for 500V, 630V series Applied 1.2 x U_r for 1KV, 2KV, 3KV series</p> <p>4. Recovery time: 24 ±2 hours</p> <p>5. Final measure: C, D, IR</p> <p>Note: If the capacitance value is less than the minimum value permitted, then after the other measurements have been made the capacitor shall be preconditioned according to "IEC 60384 4.1" and then the requirement shall be met.</p>	<p>No visual damage</p> <hr/> <p>ΔC/C NP0: Within ±2% or 1 pF, whichever is greater X7R: ±15%</p> <hr/> <p>D.F. NP0: ≤ 2 x specified value. X7R: ≤ 16V: ≤ 7% ≥ 25V: ≤ 5%</p> <p>IR NP0: ≥ 4,000 MΩ or IR x C_r ≥ 40s whichever is less X7R: ≥ 1,000 MΩ or IRx C_r ≥ 50s whichever is less</p>
External Visual	AEC-Q200	9	Any applicable method using × 10 magnification	In accordance with specification
Physical Dimension	AEC-Q200	10	Verify physical dimensions to the applicable device specification.	In accordance with specification
Mechanical Shock	AEC-Q200	13	<p>Three shocks in each direction shall be applied along the three mutually perpendicular axes of the test specimen (18 shocks)</p> <p>Peak value: 1,500 g's</p> <p>Duration: 0.5 ms</p> <p>Velocity change: 15.4 ft/s</p> <p>Waveform: Half-sin</p>	<p>ΔC/C NP0: Within ±0.5% or 0.5 pF, whichever is greater X7R: ±10%</p> <hr/> <p>D.F. Within initial specified value</p> <p>IR Within initial specified value</p>
Vibration	AEC-Q200	14	<p>5 g's for 20 minutes, 12 cycles each of 3 orientations.</p> <p>Note: Use 8" x 5" PCB. 0.31" thick 7 secure points on one long side and 2 secure points at corners of opposite sides. Parts mounted within 2" from any secure point. Test from 10-2000 Hz.</p>	<p>ΔC/C NP0: Within ±0.5% or 0.5 pF, whichever is greater X7R: ±10%</p> <hr/> <p>D.F: meet initial specified value</p> <p>IR meet initial specified value</p>

TEST	TEST METHOD		PROCEDURE	REQUIREMENTS
Resistance to Soldering Heat	AEC-Q200	15	<p>Precondition: 150 +0/-10 °C for 1 hour, then keep for 24 ±1 hours at room temperature</p> <p>Preheating: for size ≤ 1206: 120 °C to 150 °C for 1 minute</p> <p>Preheating: for size >1206: 100 °C to 120 °C for 1 minute and 170 °C to 200 °C for 1 minute</p> <p>Solder bath temperature: 260 ±5 °C</p> <p>Dipping time: 10 ±0.5 seconds</p> <p>Recovery time: 24 ±2 hours</p>	<p>Dissolution of the end face plating shall not exceed 25% of the length of the edge concerned</p> <hr/> <p>ΔC/C</p> <p>Class1:</p> <p>NP0: Within ±1% or 0.5 pF, whichever is greater.</p> <p>Class2:</p> <p>X7R: ±10%</p> <hr/> <p>D.F. within initial specified value</p> <p>IR within initial specified value</p>
Thermal Shock	AEC-Q200	16	<ol style="list-style-type: none"> 1. Preconditioning, class 2 only: 150 +0/-10 °C /1 hour, then keep for 24 ±1 hour at room temp 2. Initial measure: Spec: refer to initial spec C, D, IR 3. Rapid change of temperature test: NP0/X7R: -55 °C to +125 °C; 300 cycles 15 minutes at lower category temperature; 15 minutes at upper category temperature. 4. Recovery time: Class1: 6 to 24 hours Class2: 24 ±2 hours 5. Final measure: C, D, IR 	<p>No visual damage</p> <hr/> <p>ΔC/C</p> <p>NP0: Within ±1% or 1 pF, whichever is greater</p> <p>X7R: ±15%</p> <hr/> <p>D.F: meet initial specified value</p> <p>IR meet initial specified value</p>
ESD	AEC-Q200	17	Per AEC-Q200-004	A component passes a voltage level if all components stressed at that voltage level pass.
Solderability	AEC-Q200	18	<p>Preheated to a temperature of 80 °C to 140 °C and maintained for 30 seconds to 60 seconds.</p> <p>Test conditions for lead containing solder alloy</p> <p>Temperature: 235 ±5 °C</p> <p>Dipping time: 2 ±0.2 seconds</p> <p>Depth of immersion: 10 mm</p> <p>Alloy Composition: 60/40 Sn/Pb</p> <p>Number of immersions: 1</p> <p>Test conditions for lead-free containing solder alloy</p> <p>Temperature: 245 ±5 °C</p> <p>Dipping time: 3 ±0.3 seconds</p> <p>Depth of immersion: 10 mm</p> <p>Alloy Composition: SAC305</p> <p>Number of immersions: 1</p>	The solder should cover over 95% of the critical area of each termination.

TEST	TEST METHOD	PROCEDURE	REQUIREMENTS
Electrical Characterization	AEC-Q200 19	<p>Parametrically test per lot and sample size requirements, summary to show Min, Max, Mean and Standard deviation at room as well as Min and Max operating temperatures.</p> <p>Class 1: NP0: -55 °C to +125 °C Normal temperature: 20 °C</p> <p>Class 2: X7R: -55 °C to +125 °C Normal temperature: 20 °C</p>	<p>$\Delta C/C$</p> <p>Class 1: NP0: ± 30 ppm/°C</p> <p>Class 2: X7R: $\pm 15\%$</p>

Board Flex	AEC-Q200 21	<p>Part mounted on a 100 mm X 40 mm FR4 PCB board, which is 1.6 ± 0.2 mm thick and has a layer-thickness $35 \mu\text{m} \pm 10 \mu\text{m}$. Part should be mounted using the following soldering reflow profile.</p> <p>Conditions:</p> <p>Class 1: Bending 3 mm at a rate of 1 mm/s, radius jig 340 mm</p> <p>Class 2: Bending 2 mm at a rate of 1 mm/s, radius jig 340 mm</p>	<p>No visible damage</p> <p>$\Delta C/C$</p> <p>Class 1: NP0: Within $\pm 1\%$ or 0.5 pF, whichever is greater</p> <p>Class 2: X7R: $\pm 10\%$</p>
------------	-------------	---	---

Test Substrate:

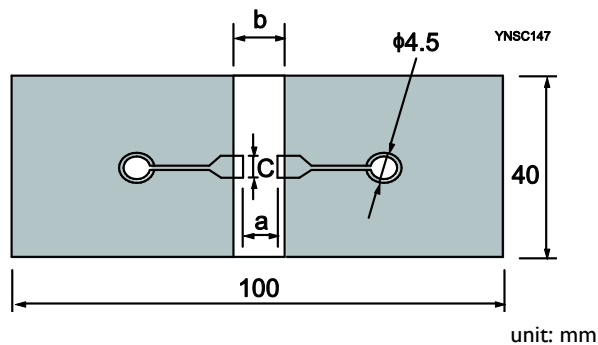

Type	Dimension(mm)		
	a	b	c
0201	0.3	0.9	0.3
0402	0.4	1.5	0.5
0603	1.0	3.0	1.2
0805	1.2	4.0	1.65
1206	2.2	5.0	1.65
1210	2.2	5.0	2.0
1808	3.5	7.0	3.7

Terminal Strength	AEC-Q200 22	<p>With the component mounted on a PCB obtained with the device to be tested, apply a 17.7N (1.8Kg) force to the side of a device being tested. This force shall be applied for 60+1 seconds. Also the force shall be applied gradually as not to apply a shock to the component being tested. * Apply 2N force for 0402 size.</p>	<p>Magnification of 20X or greater may be employed for inspection of the mechanical integrity of the device body, terminals and body/terminal junction. Before, during and after the test, the device shall comply with all electrical requirements stated in this specification.</p>
-------------------	-------------	--	---

TEST	TEST METHOD	PROCEDURE	REQUIREMENTS
Beam Load Test	AEC-Q200 23	Place the part in the beam load fixture. Apply a force until the part breaks or the minimum acceptable force level required in the user specification(s) is attained.	≤ 0805 Thickness > 0.5mm: 20N Thickness ≤ 0.5mm: 8N ≥ 1206 Thickness ≥ 1.25 mm: 54N Thickness < 1.25 mm: 15N

YNM0053

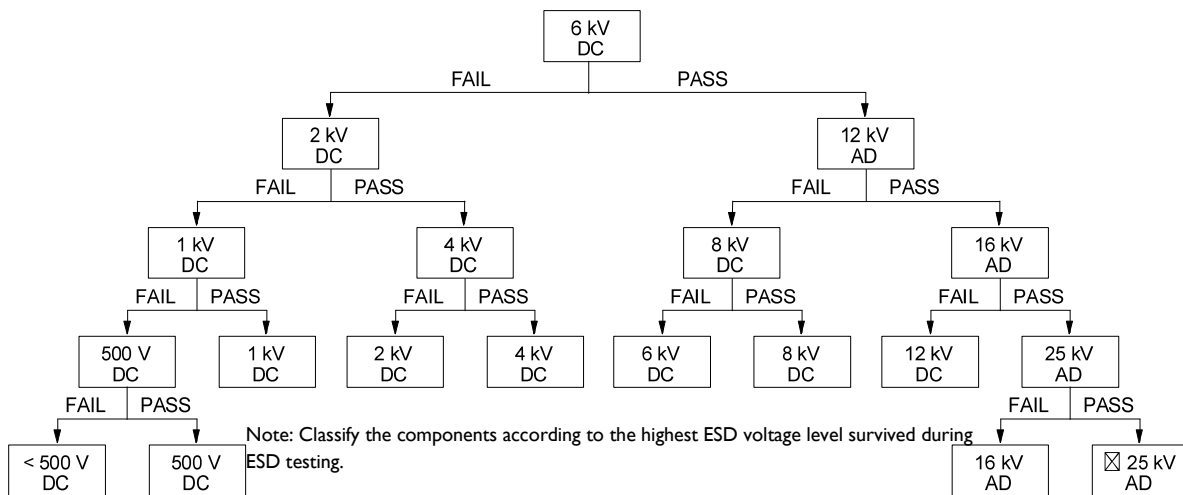

Fig. 5 Passive component HBM ESD test flow diagram (DC = Direct Contact Discharge, AD = Air Discharge)

REVISION HISTORY

REVISION	DATE	CHANGE NOTIFICATION	DESCRIPTION
Version 3	Jul. 21, 2015	-	- Tests and Requirements update
Version 2	Jul. 17, 2014	-	- Tests and Requirements update
Version 1	Apr. 19, 2013	-	- Capacitance range update
Version 0	Dec. 25, 2012	-	- New

LEGAL DISCLAIMER

Yageo, its distributors and agents (collectively, “Yageo”), hereby disclaims any and all liabilities for any errors, inaccuracies or incompleteness contained in any product related information, including but not limited to product specifications, datasheets, pictures and/or graphics. Yageo may make changes, modifications and/or improvements to product related information at any time and without notice.

Yageo makes no representation, warranty, and/or guarantee about the fitness of its products for any particular purpose or the continuing production of any of its products. To the maximum extent permitted by law, Yageo disclaims (i) any and all liability arising out of the application or use of any Yageo product, (ii) any and all liability, including without limitation special, consequential or incidental damages, and (iii) any and all implied warranties, including warranties of fitness for a particular purpose, non-infringement and merchantability.

Yageo statements regarding the suitability of products for certain types of applications are based on Yageo’s knowledge of typical operating conditions for such types of applications in a generic nature. Such statements are neither binding statements of Yageo nor intended to constitute any warranty concerning the suitability for a specific customer application or use. They are intended for use only by customers with requisite knowledge and experience for determining whether Yageo products are the correct products for their application or use. In addition, unpredictable and isolated cases of product failure may still occur, therefore, customer application or use of Yageo products which requires higher degree of reliability or safety, shall employ additional protective safeguard measures to ensure that product failure would not result in personal injury or property damage.

Yageo products are not designed for application or use in medical, life-saving, or life-sustaining devices or for any other application or use in which the failure of Yageo products could result in personal injury or death. Customers using or selling Yageo products not expressly indicated for above-mentioned purposes shall do so at their own risk and agree to fully indemnify Yageo and hold Yageo harmless.

Information provided here is intended to indicate product specifications only. Yageo reserves all the rights for revising this content without further notification, as long as products are unchanged. Any product change will be announced by PCN.