

## IGBT Modules

|           |       |
|-----------|-------|
| $V_{CES}$ | 1200V |
| $I_c$     | 15A   |

## Applications

- Motor Drivers
- AC and DC Servo Drive Amplifier
- UPS (Uninterruptible Power Supplies)

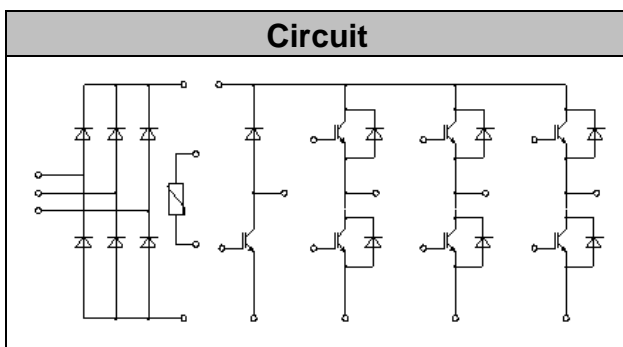

## Features

- Low switching losses
- Low  $V_{CE(sat)}$  with positive temperature coefficient
- Including fast & soft recovery anti-parallel FWD
- Low inductance case
- High short circuit capability(10us)
- Isolated heatsink using DBC technology
- Maximum junction temperature 175°C

### ● IGBT- inverter

#### Absolute Maximum Ratings

| Parameter                         | Symbol    | Conditions                                    | Value    | Unit |
|-----------------------------------|-----------|---|----------|------|
| Collector-Emitter Voltage         | $V_{CES}$ | $V_{GE}=0V, I_c = 1mA, T_{vj}=25^{\circ}C$    | 1200     | V    |
| Continuous Collector Current      | $I_c$     | $T_C=100^{\circ}C, T_{vjmax}=175^{\circ}C$    | 15       | A    |
| Repetitive Peak Collector Current | $I_{CRM}$ | $t_p=1ms$                                     | 30       | A    |
| Gate-Emitter Voltage              | $V_{GES}$ | $T_{vj}=25^{\circ}C$                          | $\pm 20$ | V    |
| Total Power Dissipation           | $P_{tot}$ | $T_C=25^{\circ}C$<br>$T_{vjmax}=175^{\circ}C$ | 155      | W    |



## ● IGBT- inverter

### Characteristic Values

| Parameter                               | Symbol        | Conditions   | Value   |       |      | Unit |    |
|---|---------------|--|---|-------|------|------|----|
|   |               |  | Min.  | Typ.  | Max. |      |    |
| Gate-Emitter Threshold Voltage          | $V_{GE(th)}$  | $V_{GE}=V_{CE}, I_C=0.5mA, T_{vj}=25^{\circ}C$                                       | 5.2   | 5.9   | 6.5  | V    |    |
| Collector-Emitter Cut-off Current       | $I_{CES}$     | $V_{CE}=1200V, V_{GE}=0V, T_{vj}=25^{\circ}C$  |   |       | 1.0  | mA   |    |
| Collector-Emitter Saturation Voltage    | $V_{CE(sat)}$ | $I_C=15A, V_{GE}=15V, T_{vj}=25^{\circ}C$  |   | 1.9   |      | V    |    |
|   |               | $I_C=15A, V_{GE}=15V, T_{vj}=125^{\circ}C$   |   | 2.1   |      |      |    |
|   |               | $I_C=15A, V_{GE}=15V, T_{vj}=150^{\circ}C$   |   | 2.2   |      |      |    |
| Gate Charge                             | $Q_G$         |  |   | 0.15  |      | uC   |    |
| Input Capacitance                       | $C_{ies}$     | $V_{CE}=25V, V_{GE}=0V, f=1MHz, T_{vj}=25^{\circ}C$                                  |   | 0.98  |      | nF   |    |
| Reverse Transfer Capacitance            | $C_{res}$     |  |   | 0.034 |      | nF   |    |
| Gate-Emitter leakage current            | $I_{GES}$     | $V_{CE}=0V, V_{GE}=20V, T_{vj}=25^{\circ}C$  |   |       | 400  | nA   |    |
| Turn-on Delay Time                      | $t_{d(on)}$   | $I_C=15A, V_{CE}=600V, V_{GE}=\pm 15V, R_G=39\Omega, T_{vj}=25^{\circ}C$             |   | 61    |      | ns   |    |
| Rise Time                               | $t_r$         |  |   | 29    |      | ns   |    |
| Turn-off Delay Time                     | $t_{d(off)}$  |  |   | 89    |      | ns   |    |
| Fall Time                               | $t_f$         |  |   | 311   |      | ns   |    |
| Energy Dissipation During Turn-on Time  | $E_{on}$      |  |   | 1.98  |      | mJ   |    |
| Energy Dissipation During Turn-off Time | $E_{off}$     |  |   | 0.99  |      | mJ   |    |
| Turn-on Delay Time                      | $t_{d(on)}$   |  | $I_C=15A, V_{CE}=600V, V_{GE}=\pm 15V, R_G=39\Omega, T_{vj}=150^{\circ}C$ |       | 60   |      | ns |
| Rise Time                               | $t_r$         |  |   |       | 32   |      | ns |
| Turn-off Delay Time                     | $t_{d(off)}$  |  |   |       | 89   |      | ns |
| Fall Time                               | $t_f$         |  |   |       | 319  |      | ns |
| Energy Dissipation During Turn-on Time  | $E_{on}$      |  |   | 2.15  |      | mJ   |    |
| Energy Dissipation During Turn-off Time | $E_{off}$     |  |   | 1.13  |      | mJ   |    |
| SC Data                                 | $I_{sc}$      | $t_p \leq 10\mu s, V_{GE}=15V, T_{vj}=150^{\circ}C, V_{CC}=900V, V_{CEM} \leq 1200V$ |   |       | 55   |      | A  |



## ● Diode-inverter

### Absolute Maximum Ratings

| Parameter                       | Symbol    | Conditions                              | Value | Unit             |
|---------------------------------|-----------|---|-------|------------------|
| Repetitive Peak Reverse Voltage | $V_{RRM}$ | $T_{vj}=25^{\circ}C$                    | 1200  | V                |
| Continuous DC Forward Current   | $I_F$     |   | 15    | A                |
| Repetitive Peak Forward Current | $I_{FRM}$ | $t_p=1ms$                               | 30    | A                |
| $I^2t$ -value                   | $I^2t$    | $V_R=0V, t_p=10ms, T_{vj}=125^{\circ}C$ | 16.0  | A <sup>2</sup> s |
|                                 |           | $V_R=0V, t_p=10ms, T_{vj}=150^{\circ}C$ | 14.0  |                  |

### Characteristic Values

| Parameter                     | Symbol    | Conditions                            | Value |      |      | Unit    |
|-------------------------------|-----------|---------------------------------------|-------|------|------|---------|
|                               |           |                                       | Min.  | Typ. | Max. |         |
| Forward Voltage               | $V_F$     | $I_F=15A, T_{vj}=25^{\circ}C$         |       | 2.00 |      | V       |
|                               |           | $I_F=15A, T_{vj}=125^{\circ}C$        |       | 1.80 |      |         |
|                               |           | $I_F=15A, T_{vj}=150^{\circ}C$        |       | 1.75 |      |         |
| Recovered Charge              | $Q_{rr}$  | $I_F=15A$                             |       | 0.45 |      | $\mu C$ |
| Peak Reverse Recovery Current | $I_{rr}$  | $V_R=600V$<br>$-di_F/dt = 600A/\mu s$ |       | 13   |      | A       |
| Reverse Recovery Energy       | $E_{rec}$ | $T_{vj}=25^{\circ}C$                  |       | 0.49 |      | mJ      |
| Recovered Charge              | $Q_{rr}$  | $I_F=15A$                             |       | 0.54 |      | $\mu C$ |
| Peak Reverse Recovery Current | $I_{rr}$  | $V_R=600V$<br>$-di_F/dt = 600A/\mu s$ |       | 14   |      | A       |
| Reverse Recovery Energy       | $E_{rec}$ | $T_{vj}=150^{\circ}C$                 |       | 0.68 |      | mJ      |



● **IGBT-brake-chopper**  
**Absolute Maximum Ratings**

| Parameter                         | Symbol    | Conditions                                 | Value    | Unit |
|-----------------------------------|-----------|--|----------|------|
| Collector-Emitter Voltage         | $V_{CES}$ | $V_{GE}=0V, I_C=1mA, T_{vj}=25^{\circ}C$   | 1200     | V    |
| Continuous Collector Current      | $I_C$     | $T_C=100^{\circ}C, T_{vjmax}=175^{\circ}C$ | 15       | A    |
| Repetitive Peak Collector Current | $I_{CRM}$ | $t_p=1ms$                                  | 30       | A    |
| Gate-Emitter Voltage              | $V_{GES}$ | $T_{vj}=25^{\circ}C$                       | $\pm 20$ | V    |
| Total Power Dissipation           | $P_{tot}$ | $T_C=25^{\circ}C, T_{vjmax}=175^{\circ}C$  | 155      | W    |

**Characteristic Values**

| Parameter                               | Symbol        | Conditions   | Value |       |      | Unit |    |
|---|---------------|--|-------|-------|------|------|----|
|   |               |  | Min.  | Typ.  | Max. |      |    |
| Gate-emitter Threshold Voltage          | $V_{GE(th)}$  | $V_{GE}=V_{CE}, I_C=0.5mA, T_{vj}=25^{\circ}C$                           | 5.2   | 5.9   | 6.5  | V    |    |
| Collector-Emitter Cut-off Current       | $I_{CES}$     | $V_{CE}=1200V, V_{GE}=0V, T_{vj}=25^{\circ}C$                            |       |       | 1.0  | mA   |    |
| Collector-Emitter Saturation Voltage    | $V_{CE(sat)}$ | $I_C=15A, V_{GE}=15V, T_{vj}=25^{\circ}C$                                |       | 1.9   |      | V    |    |
|   |               | $I_C=15A, V_{GE}=15V, T_{vj}=125^{\circ}C$                               |       | 2.1   |      |      |    |
|   |               | $I_C=15A, V_{GE}=15V, T_{vj}=150^{\circ}C$                               |       | 2.2   |      |      |    |
| Gate Charge                             | $Q_G$         |  |       | 0.09  |      | uC   |    |
| Input Capacitance                       | $C_{ies}$     | $V_{CE}=25V, V_{GE}=0V, f=1MHz, T_{vj}=25^{\circ}C$                      |       | 0.98  |      | nF   |    |
| Reverse Transfer Capacitance            | $C_{res}$     |  |       | 0.034 |      | nF   |    |
| Gate-Emitter leakage current            | $I_{GES}$     | $V_{CE}=0V, V_{GE}=20V, T_{vj}=25^{\circ}C$                              |       |       | 400  | nA   |    |
| Turn-on Delay Time                      | $t_{d(on)}$   | $I_C=15A, V_{CE}=600V, V_{GE}=\pm 15V, R_G=39\Omega, T_{vj}=25^{\circ}C$ |       | 61    |      | ns   |    |
| Rise Time                               | $t_r$         |  |       | 29    |      | ns   |    |
| Turn-off Delay Time                     | $t_{d(off)}$  |  |       | 89    |      | ns   |    |
| Fall Time                               | $t_f$         |  |       | 311   |      | ns   |    |
| Energy Dissipation During Turn-on Time  | $E_{on}$      |  |       |       | 1.98 |      | mJ |
| Energy Dissipation During Turn-off Time | $E_{off}$     |  |       |       | 0.99 |      | mJ |



|   |              |  |  |    |
|---|--------------|--|--|----|
| Turn-on Delay Time                      | $t_{d(on)}$  | $I_C=15A$<br>$V_{CE}=600V$<br>$V_{GE}=\pm 15V$<br>$R_G=39\Omega$<br>$T_{vj}=150^\circ C$ | 60   | ns |
| Rise Time                               | $t_r$        |  | 32   | ns |
| Turn-off Delay Time                     | $t_{d(off)}$ |  | 89   | ns |
| Fall Time                               | $t_f$        |  | 319  | ns |
| Energy Dissipation During Turn-on Time  | $E_{on}$     |  | 2.15   | mJ |
| Energy Dissipation During Turn-off Time | $E_{off}$    |  | 1.13   | mJ |
| SC Data                                 | $I_{SC}$     |  | $t_p \leq 10\mu s, V_{GE}=15V, T_{vj}=150^\circ C,$<br>$V_{CC}=900V, V_{CEM} \leq 1200V$ | 55 |

## ● Diode-brake-chopper

### Absolute Maximum Ratings

| Parameter                       | Symbol    | Conditions                             | Value | Unit             |
|---------------------------------|-----------|--|-------|------------------|
| Repetitive Peak Reverse Voltage | $V_{RRM}$ | $T_{vj}=25^\circ C$                    | 1200  | V                |
| Continuous DC Forward Current   | $I_F$     |  | 10    | A                |
| Repetitive Peak Forward Current | $I_{FRM}$ | $t_p=1ms$                              | 20    | A                |
| I <sup>2</sup> t-value          | $I^2t$    | $V_R=0V, t_p=10ms, T_{vj}=125^\circ C$ | 16.0  | A <sup>2</sup> s |
|                                 |           | $V_R=0V, t_p=10ms, T_{vj}=150^\circ C$ | 14.0  |                  |

### Characteristic Values

| Parameter                     | Symbol    | Conditions                            | Value |      |      | Unit |
|-------------------------------|-----------|---------------------------------------|-------|------|------|------|
|                               |           |                                       | Min.  | Typ. | Max. |      |
| Forward Voltage               | $V_F$     | $I_F=10A, T_{vj}=25^\circ C$          |       | 2.00 |      | V    |
|                               |           | $I_F=10A, T_{vj}=125^\circ C$         |       | 1.85 |      |      |
|                               |           | $I_F=10A, T_{vj}=150^\circ C$         |       | 1.80 |      |      |
| Recovered Charge              | $Q_{rr}$  | $I_F=10A$                             |       | 0.26 |      | uC   |
| Peak Reverse Recovery Current | $I_{rr}$  | $V_R=600V$<br>$-di_F/dt = 500A/\mu s$ |       | 11   |      | A    |
| Reverse Recovery Energy       | $E_{rec}$ | $T_{vj}=25^\circ C$                   |       | 0.25 |      | mJ   |
| Recovered Charge              | $Q_{rr}$  | $I_F=10A$                             |       | 0.49 |      | uC   |
| Peak Reverse Recovery Current | $I_{rr}$  | $V_R=600V$<br>$-di_F/dt = 500A/\mu s$ |       | 13   |      | A    |
| Reverse Recovery Energy       | $E_{rec}$ | $T_{vj}=150^\circ C$                  |       | 0.50 |      | mJ   |



## ● Diode-rectifier

### Absolute Maximum Ratings

| Parameter                                    | Symbol           | Conditions                              | Value | Unit             |
|--|------------------|---|-------|------------------|
| Repetitive Peak Reverse Voltage              | $V_{RRM}$        | $T_{vj}=25^{\circ}C$                    | 1600  | V                |
| Average output Current<br>50/60Hz, sine wave | $I_{F(AV)}$      | $T_C=100^{\circ}C$                      | 20    | A                |
| Maximum RMS Current at<br>Rectifier Output   | $I_{RMSM}$       | $T_C=100^{\circ}C$                      | 40    | A                |
| Surge Forward Current                        | $I_{FSM}$        | $V_R=0V, t_p=10ms, T_{vj}=25^{\circ}C$  | 330   | A                |
|  |                  | $V_R=0V, t_p=10ms, T_{vj}=150^{\circ}C$ | 280   | A                |
| I <sup>2</sup> t-value                       | I <sup>2</sup> t | $V_R=0V, t_p=10ms, T_{vj}=25^{\circ}C$  | 520   | A <sup>2</sup> s |
|  |                  | $V_R=0V, t_p=10ms, T_{vj}=150^{\circ}C$ | 390   | A <sup>2</sup> s |

### Characteristic Values

| Parameter             | Symbol | Conditions                       | Value |      |      | Unit |
|-----------------------|--------|----------------------------------|-------|------|------|------|
|                       |        |                                  | Min.  | Typ. | Max. |      |
| Diode Forward Voltage | $V_F$  | $I_F=15A, T_{vj}=150^{\circ}C$   |       | 0.96 |      | V    |
| Reverse Current       | $I_R$  | $T_{vj}=150^{\circ}C, V_R=1600V$ |       |      | 1.0  | mA   |

## ● NTC-thermistor

### Characteristic Values

| Parameter         | Symbol       | Conditions                                      | Value |      |      | Unit       |
|-------------------|--------------|---|-------|------|------|------------|
|                   |              |   | Min.  | Typ. | Max. |            |
| Rated Resistance  | $R_{25}$     |   |       | 5.0  |      | k $\Omega$ |
| Deviation of R100 | $\Delta R/R$ | $T_C=100^{\circ}C, R_{100}=493.3\Omega$         | -5    |      | 5    | %          |
| Power Dissipation | $P_{25}$     |   |       |      | 20.0 | mW         |
| B-value           | $B_{25/50}$  | $R_2=R_{25}\exp[B_{25/50}(1/T_2-1/(298.15 K))]$ |       | 3375 |      | K          |



## ● Module Characteristics

$T_c=25^{\circ}\text{C}$  unless otherwise specified

| Parameter                                 | Symbol                      | Conditions                            | Value |       |      | Unit               |
|---|-----------------------------|---------------------------------------|-------|-------|------|--------------------|
|   |                             |                                       | Min.  | Typ.  | Max. |                    |
| Isolation Voltage                         | $V_{\text{isol}}$           | $t=1\text{min}, f=50\text{Hz}$        | 2500  |       |      | V                  |
| Maximum Junction Temperature              | $T_{\text{jmax}}$           |                                       |       |       | 175  | $^{\circ}\text{C}$ |
| Operating Junction Temperature            | $T_{\text{vj op}}$          |                                       | -40   |       | 150  | $^{\circ}\text{C}$ |
| Storage Temperature                       | $T_{\text{stg}}$            |                                       | -40   |       | 125  | $^{\circ}\text{C}$ |
| Stray-inductance-module                   | $L_{\text{SCE}}$            |                                       |       | 30    |      | nH                 |
| Module lead resistance,<br>terminals-chip | $R_{\text{CC}'+\text{EE}}$  | $T_c=25^{\circ}\text{C}$ , per switch |       | 8.00  |      | m $\Omega$         |
|   | $R_{\text{AA}'+\text{CC}'}$ |                                       |       | 6.00  |      |                    |
| Thermal Resistance<br>Junction-to Case    | $R_{\theta\text{JC}}$       | per IGBT-inverter                     |       | 0.95  | 1.05 | K/W                |
|   |                             | per Diode-inverter                    |       | 1.30  | 1.45 |                    |
|   |                             | per IGBT-brake-chopper                |       | 0.95  | 1.05 |                    |
|   |                             | per Diode-chopper                     |       | 1.75  | 1.90 |                    |
|   |                             | per Diode-rectifier                   |       | 1.03  | 1.13 |                    |
| Thermal Resistance<br>Case-to Sink        | $R_{\theta\text{CS}}$       | per IGBT-inverter                     |       | 0.95  |      | K/W                |
|   |                             | per Diode-inverter                    |       | 1.05  |      |                    |
|   |                             | per IGBT-brake-chopper                |       | 0.95  |      |                    |
|   |                             | per Diode-chopper                     |       | 1.30  |      |                    |
|   |                             | per Diode-rectifier                   |       | 1.17  |      |                    |
|   |                             | per Module                            |       | 0.058 |      |                    |
| Mounting Force Per Clamp                  | F                           |                                       | 20    |       | 50   | N                  |
| Weight of Module                          | G                           |                                       |       | 25    |      | g                  |

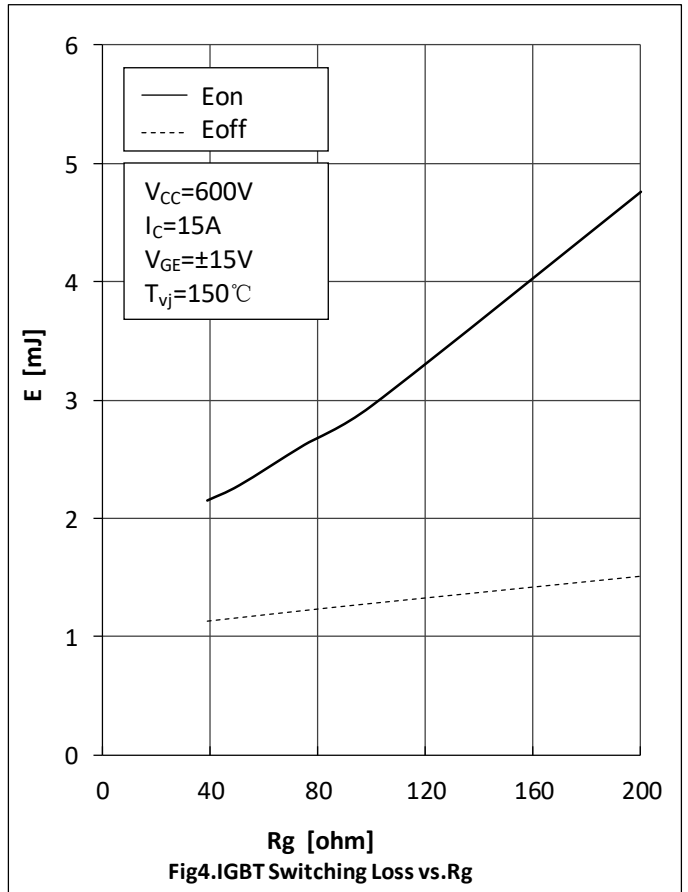
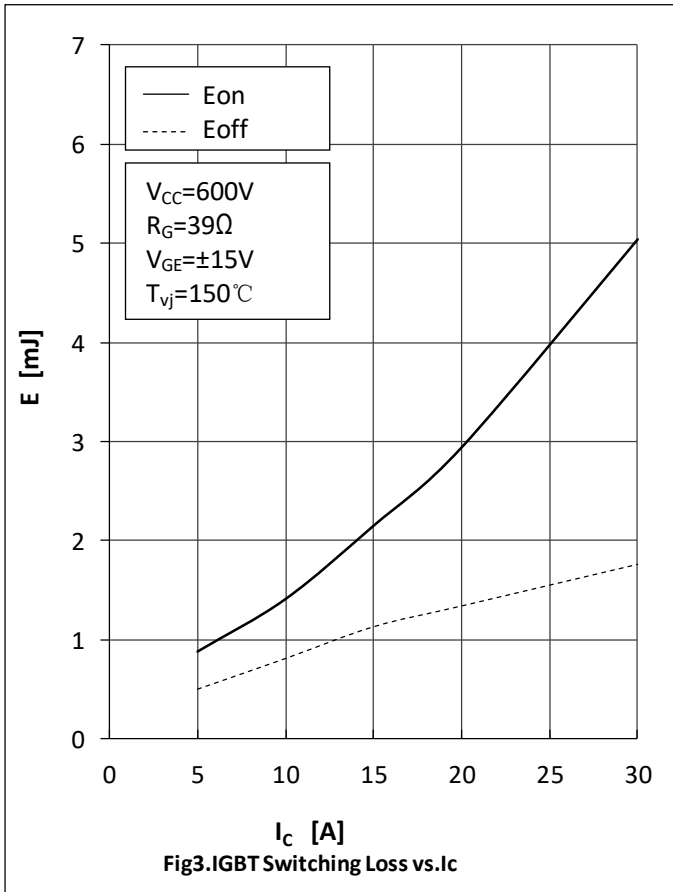
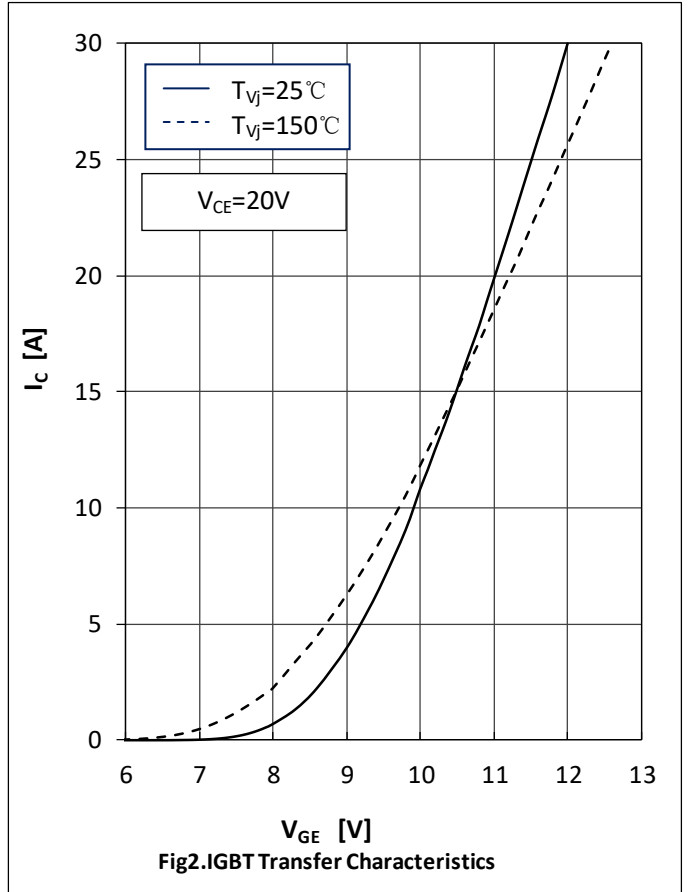
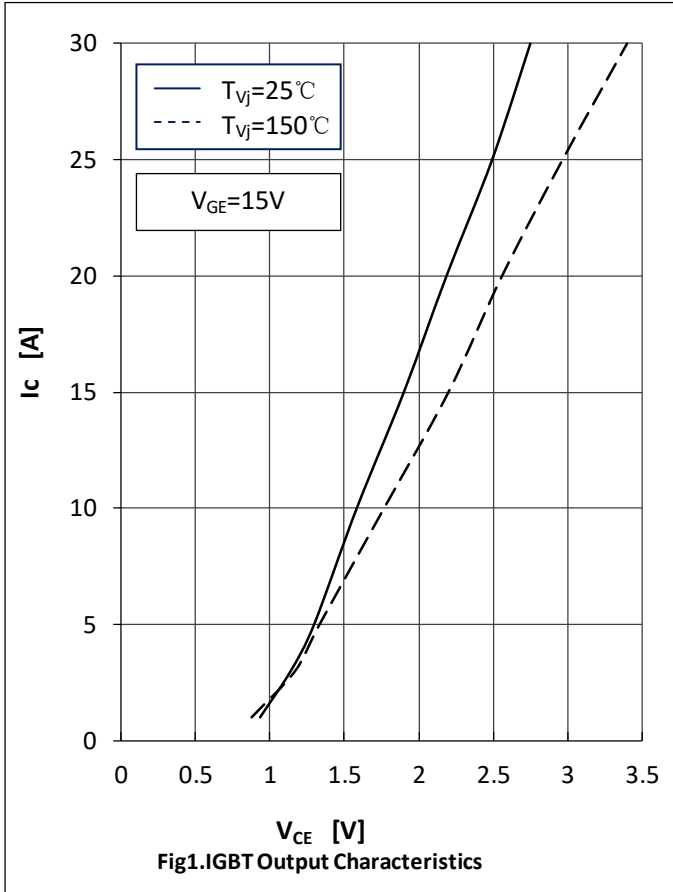

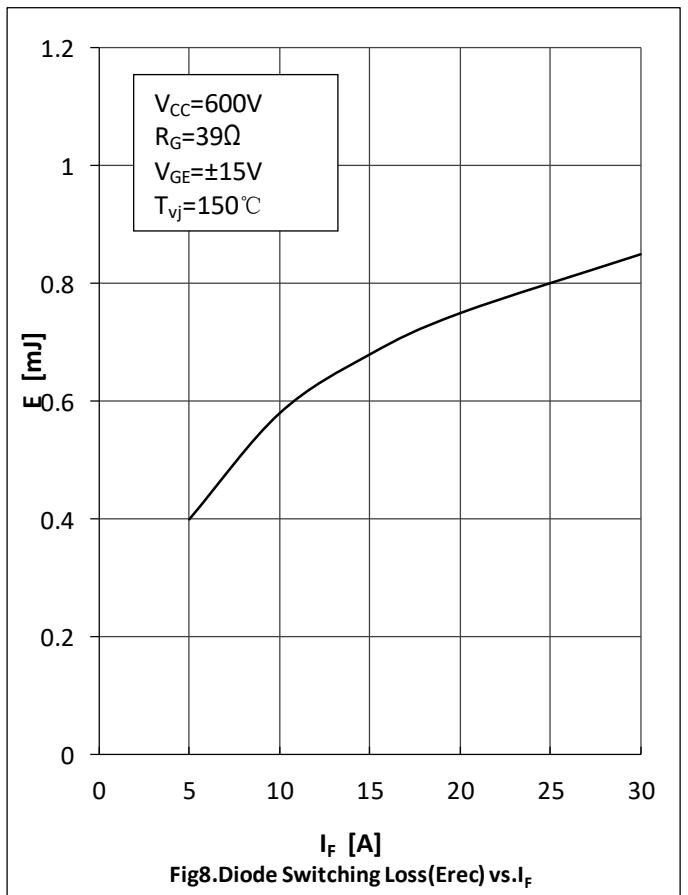
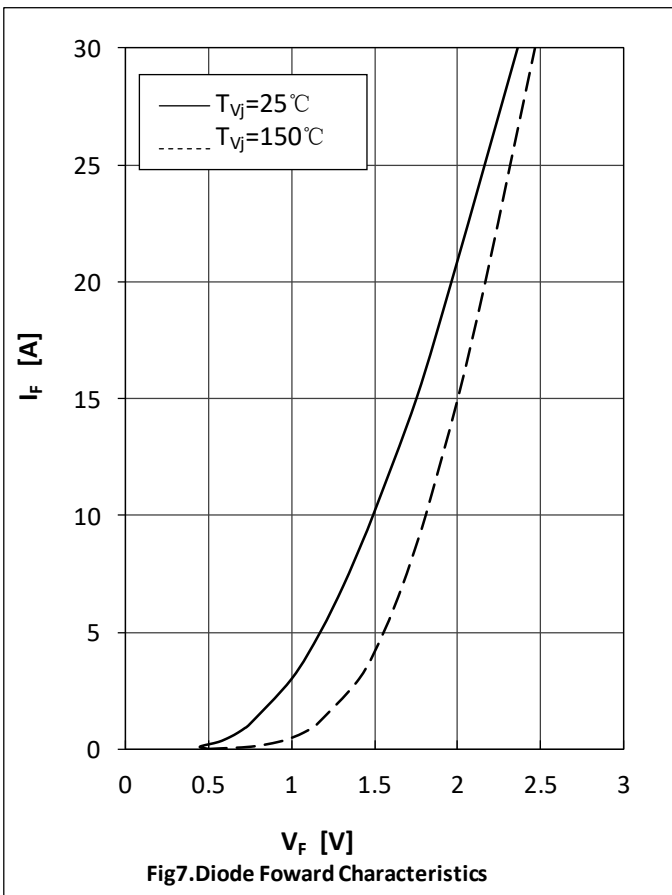
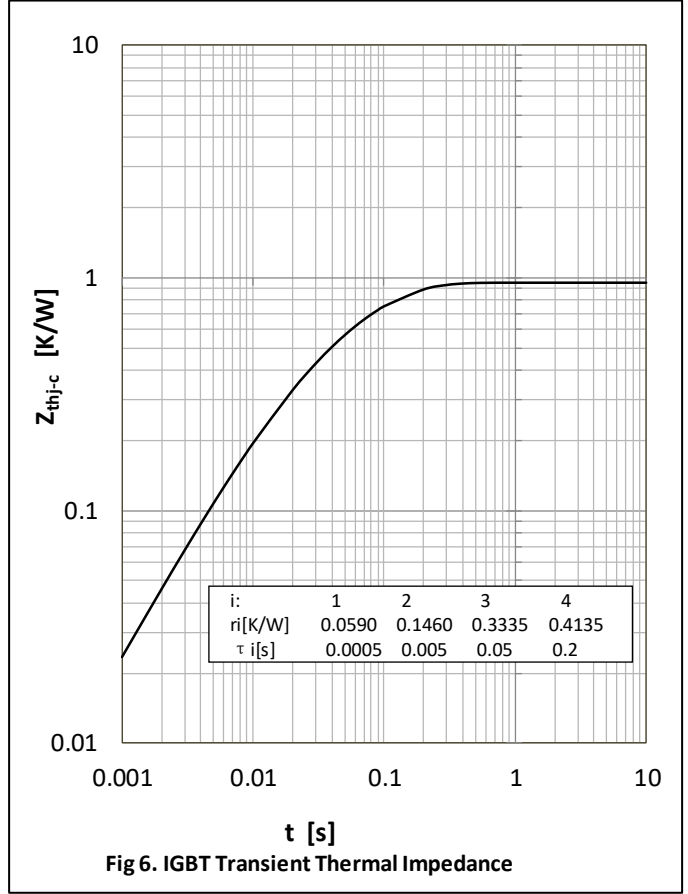
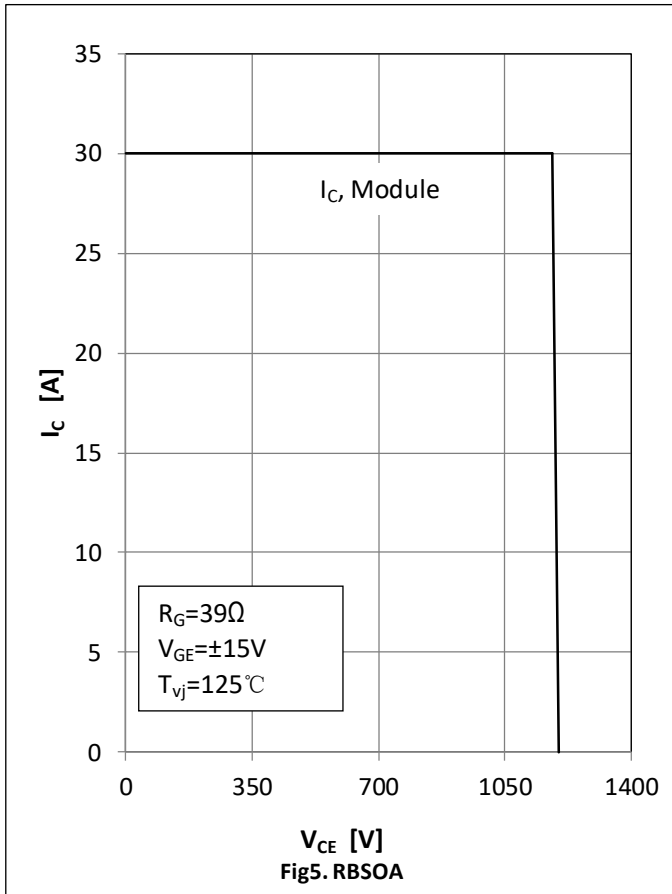

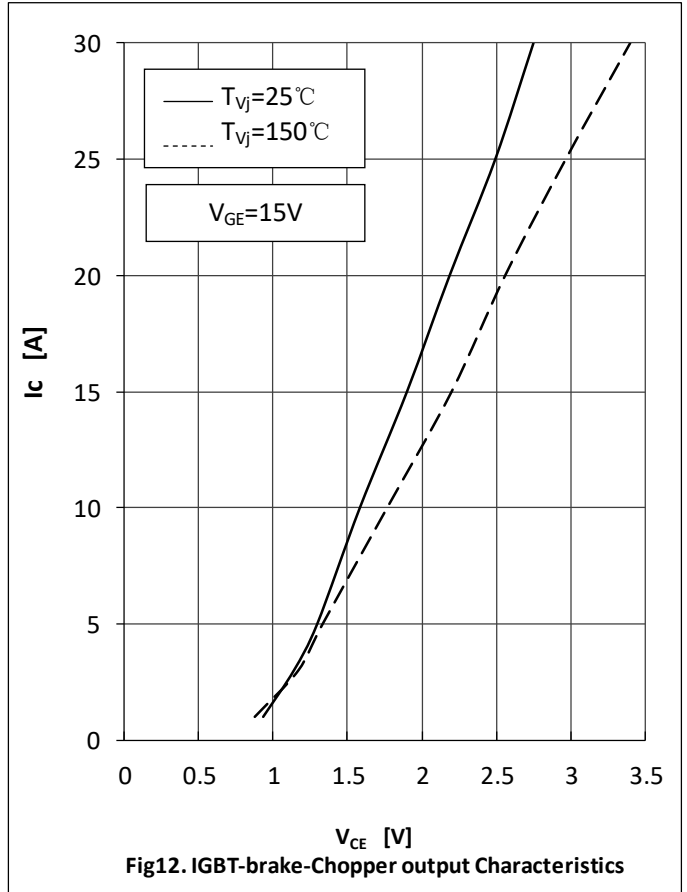
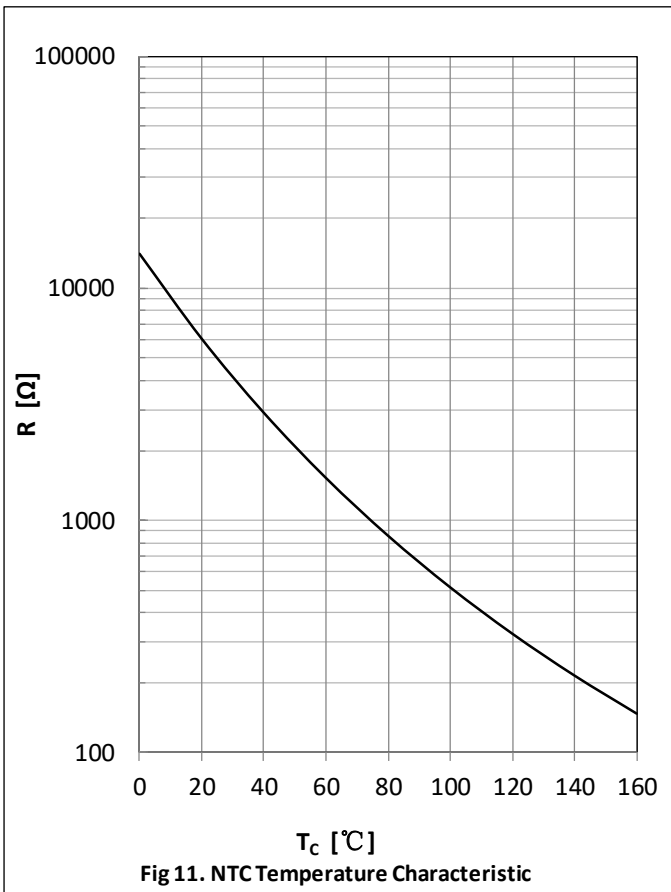
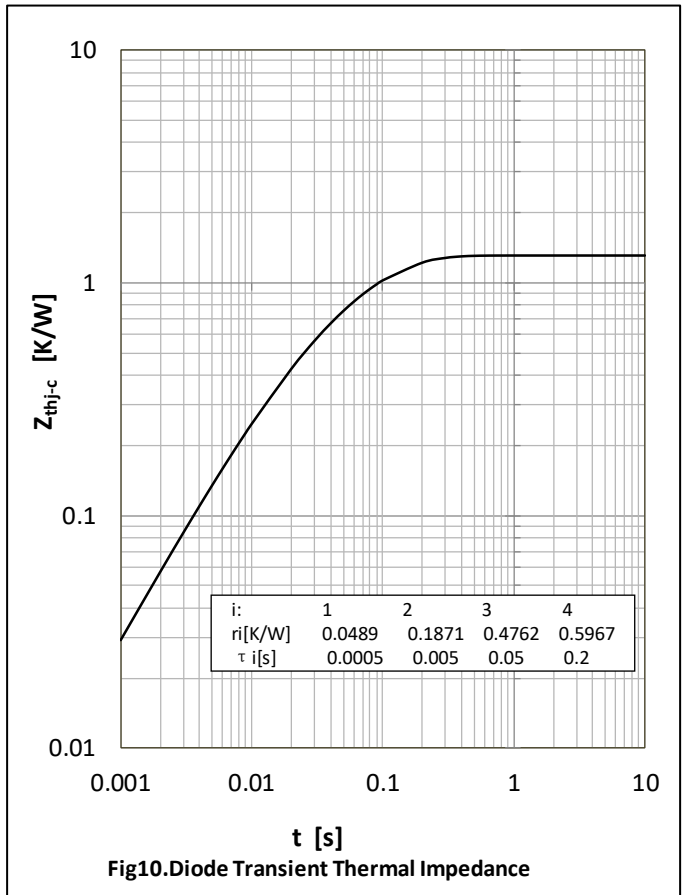
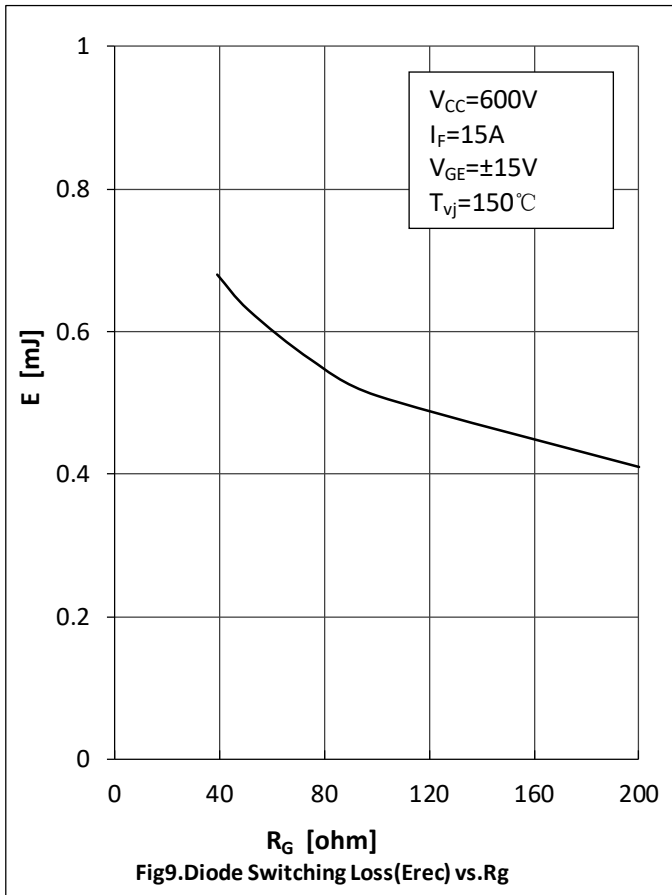

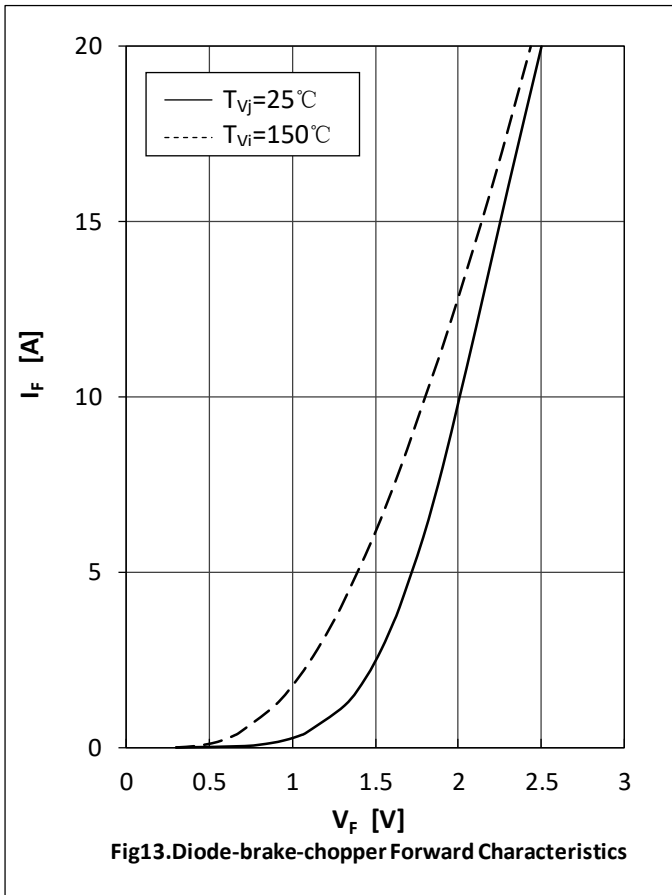



## Circuit Diagram

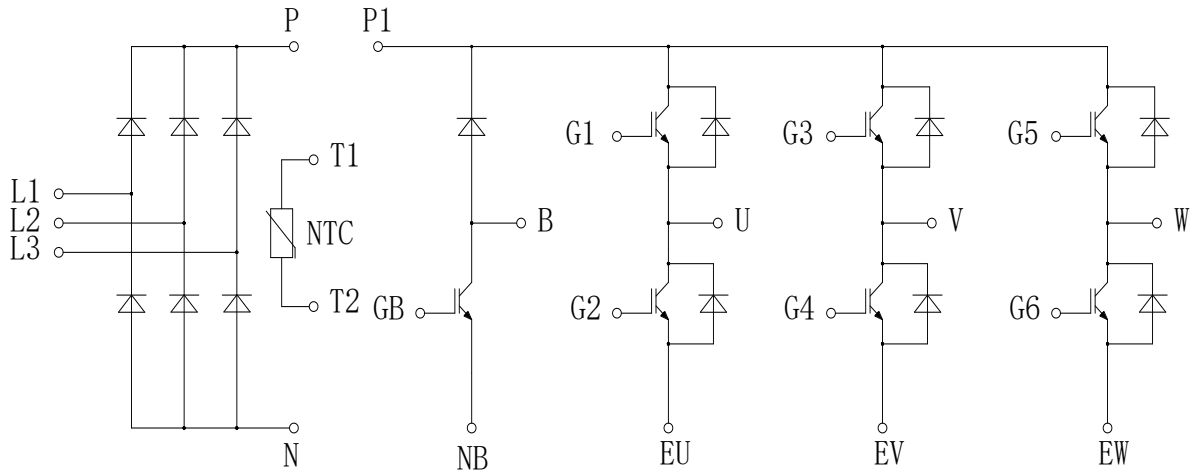

## Package Dimensions

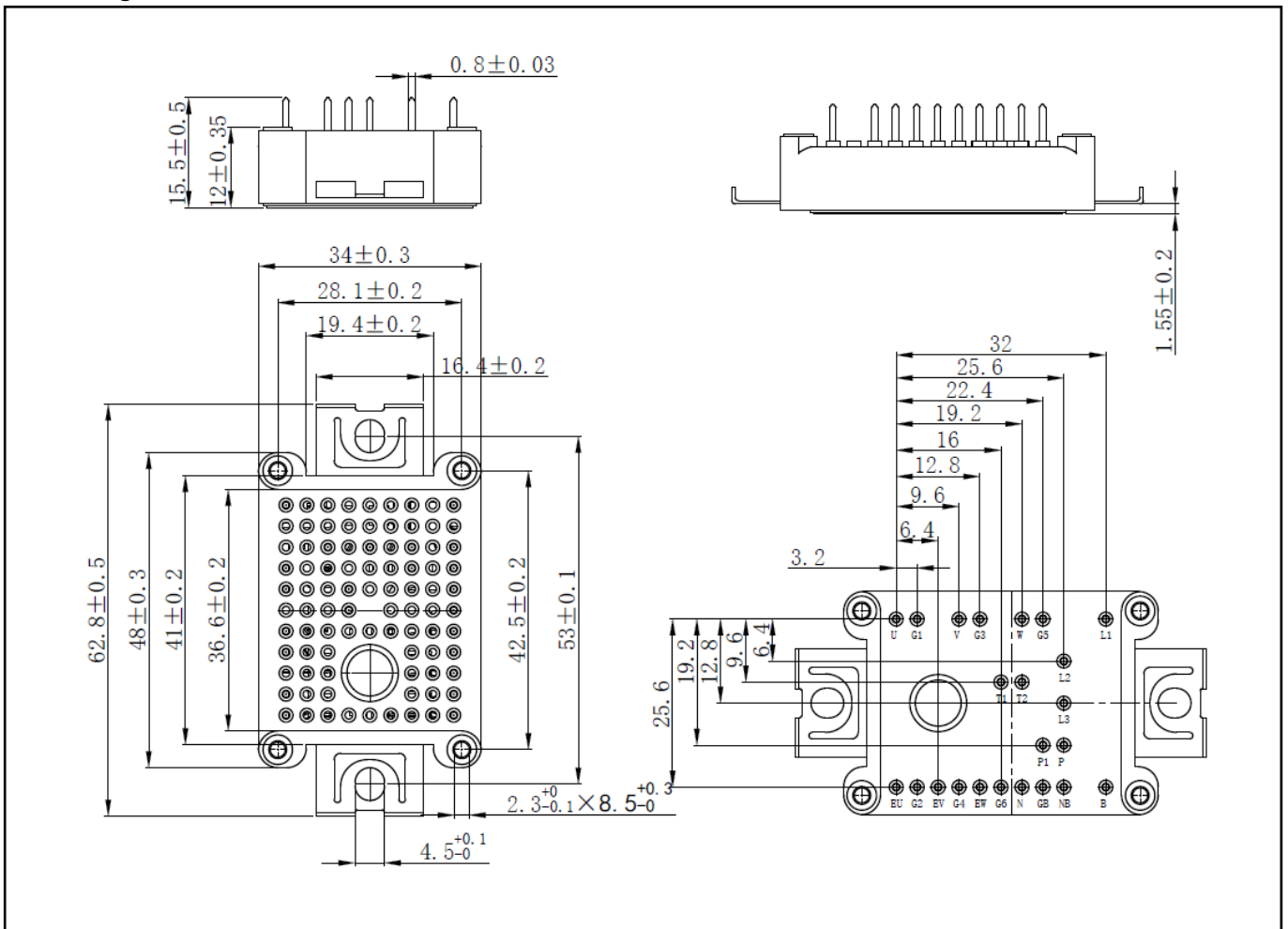



## Disclaimer

The information presented in this document is for reference only. Yangzhou Yangjie Electronic Technology Co., Ltd. reserves the right to make changes without notice for the specification of the products displayed herein to improve reliability, function or design or otherwise.

The product listed herein is designed to be used with ordinary electronic equipment or devices, and not designed to be used with equipment or devices which require high level of reliability and the malfunction of with would directly endanger human life (such as aerospace machinery, nuclear-reactor controllers, fuel controllers and other safety devices), Yangjie or anyone on its behalf, assumes no responsibility or liability for any damages resulting from such improper use of sale.

This publication supersedes & replaces all information previously supplied. For additional information, please visit our website [http:// www.21yangjie.com](http://www.21yangjie.com) , or consult your nearest Yangjie's sales office for further assistance.